



M2115

LINEAR INTEGRATED CIRCUIT

DUAL OPERATIONAL AMPLIFIER

■ DESCRIPTION

The UTC **M2115** is a low operating Voltage($\pm 1.0V$ min.) and low saturation output voltage($\pm 2.0V$ p-p at supply voltage $\pm 2.5V$) operational amplifier. It is applicable to handy type CD, radio cassette CD, and portable DAT, that are digital audio apparatus which require the 5V single supply operation and high output voltage. The UTC **M2115** is improved version of the UTC M2100 about BIAS-CIRCUIT. So the UTC **M2115** is low saturation compared to the UTC M2100 under the condition of low supply voltage($< \pm 2.5V$). The UTC **M2115** is stable about the oscillation compared to the UTC M2100 under the condition of $V+/V- > 2.5V$.

■ FEATURES

- * Operating Voltage: $\pm 1V \sim \pm 7V$
- * Low Saturation Output Voltage: $\pm 2.0V_{p-p} @ V+ = \pm 2.5V$
- * Slew Rate: $4V/\mu s$ (typ.)
- * Unity Gain Bandwidth: 12MHz (typ.)

■ ORDERING INFORMATION

Ordering Number		Package	Packing
Lead Free	Halogen Free		
M2115L-D08-T	M2115G-D08-T	DIP-8	Tube
-	M2115G-S08-R	SOP-8	Tape Reel
-	M2115G-P08-R	TSSOP-8	Tape Reel

<p>M2115L-D08-T</p> <p>(1) Packing Type (2) Package Type (3) Green Package</p>	<p>(1) R: Tape Reel, T: Tube (2) D08: DIP-8, S08: SOP-8, P08: TSSOP-8 (3) L: Lead Free, G: Halogen Free and Lead Free</p>
--	---

■ MARKING

DIP-8	SOP-8	TSSOP-8
<p>UTC □ □ □ □ → Date Code M2115□ □ → Lot Code L: Lead Free G: Halogen Free</p>	<p>UTC □ □ □ □ → Date Code M2115G □ □ → Lot Code</p>	<p>UTC □ □ □ □ → Date Code M2115G □ □ → Lot Code</p>

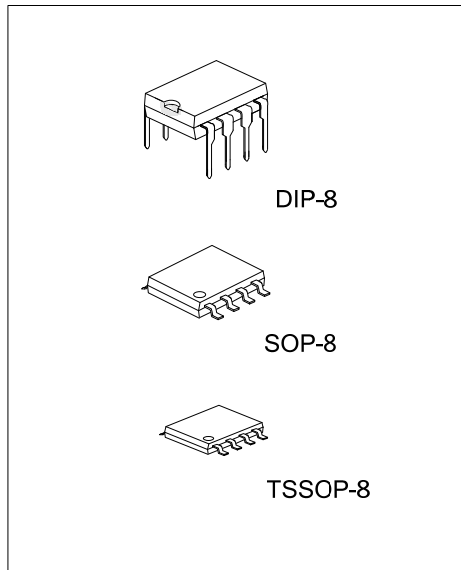

■ PIN CONFIGURATION

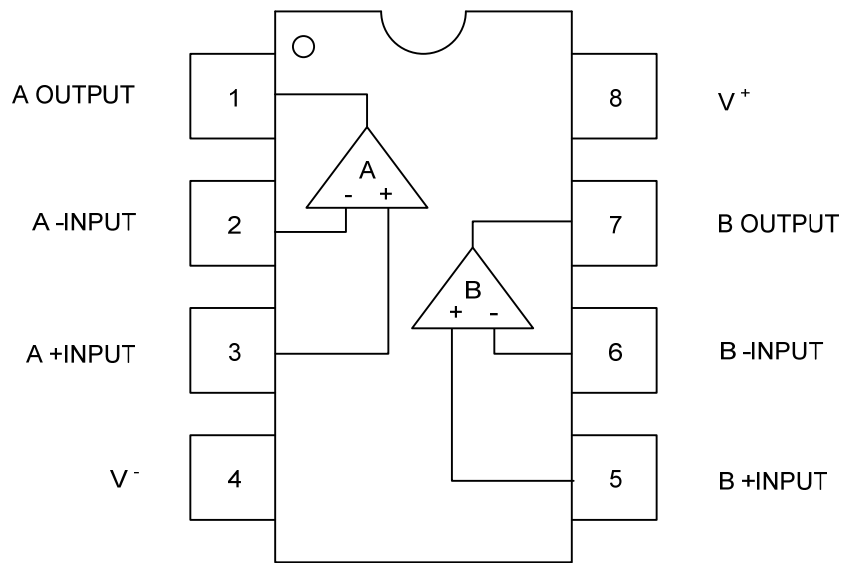

■ EQUIVALENT CIRCUIT (1/2 Shown)

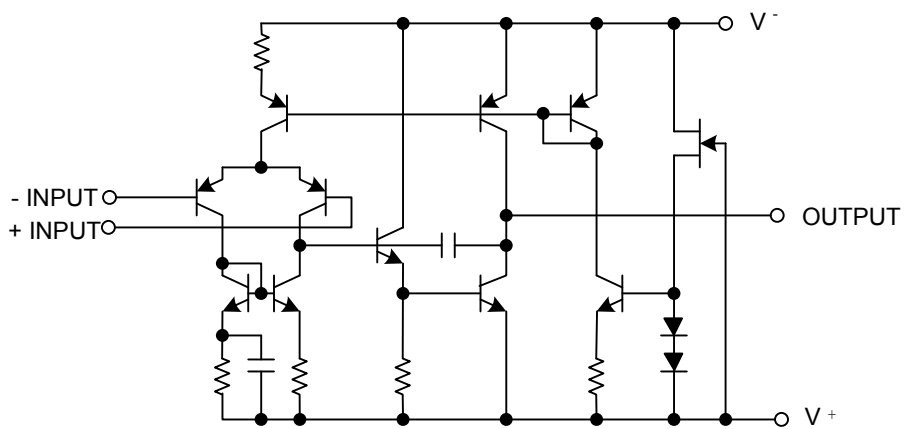

FLYING 汎翔國際有限公司
www.flying1688.com

■ ABSOLUTE MAXIMUM RATINGS ($T_A=25^{\circ}\text{C}$, unless otherwise specified)

PARAMETER	SYMBOL	RATINGS	UNIT
Supply Voltage	V^+ / V^-	± 7.0	V
Differential Input Voltage	$V_{I(DIFF)}$	± 14	V
Power Dissipation	DIP-8	500	mW
	SOP-8	300	
	TSSOP-8	250	
Operating Temperature	T_{OPR}	$-40 \sim +85$	$^{\circ}\text{C}$
Storage Temperature	T_{STG}	$-40 \sim +125$	$^{\circ}\text{C}$

Note: Absolute maximum ratings are those values beyond which the device could be permanently damaged.

Absolute maximum ratings are stress ratings only and functional device operation is not implied.

■ ELECTRICAL CHARACTERISTICS ($V^+ / V^- = \pm 2.5\text{V}$, $T_A=25^{\circ}\text{C}$, unless otherwise specified)

PARAMETER	SYMBOL	TEST CONDITION	MIN	TYP	MAX	UNIT
Input Offset Voltage	$V_{I(OFF)}$	$R_s \leq 10\text{k}\Omega$		1	6	mV
Input Bias Current	$I_{I(BIAS)}$			100	300	nA
Operating Current	I_{CC}	$V_{IN}=0, R_L=\infty$		3.5	5	mA
Maximum Output Voltage Swing	V_{OM}	$R_L \geq 2.5\text{k}\Omega$	± 2	± 2.2		V
Input Common Mode Voltage Range	V_{ICM}		± 1.5			V
Large Signal Voltage Gain	G_V	$R_L \geq 10\text{k}\Omega$	60	80		dB
Common Mode Rejection Ratio	CMRR		60	74		dB
Supply Voltage Rejection Ratio	SVR		60	80		dB
Slew Rate	SR	$V_{IN}=\pm 1\text{V}, G_V=1$		4		$\text{V}/\mu\text{s}$
Gain Bandwidth product	GB	$f=10\text{kHz}$		12		MHz

Notes: 1. Applied circuit voltage gain is desired to be operated within the range of 3dB to 30dB. 2. Repetitive Rating : Pulse width limited by T_J .

2. Special care being required for input common mode voltage range and the oscillation due to the capacitive load when operating follower.

UTC assumes no responsibility for equipment failures that result from using products at values that exceed, even momentarily, rated values (such as maximum ratings, operating condition ranges, or other parameters) listed in products specifications of any and all UTC products described or contained herein. UTC products are not designed for use in life support appliances, devices or systems where malfunction of these products can be reasonably expected to result in personal injury. Reproduction in whole or in part is prohibited without the prior written consent of the copyright owner. The information presented in this document does not form part of any quotation or contract, is believed to be accurate and reliable and may be changed without notice.