



## MC33272

Preliminary

BIPOLAR IC

### SINGLE SUPPLY, HIGH SLEW RATE, LOW INPUT OFFSET VOLTAGE OPERATIONAL AMPLIFIERS

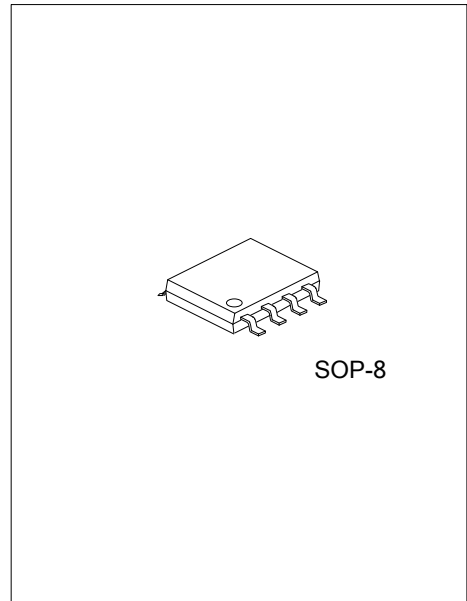

#### DESCRIPTION

The UTC **MC33272** is a Bipolar dual operational amplifier with high performance concepts. This amplifier exhibits low input voltage noise with high gain bandwidth product and slew rate. The all NPN output stage exhibits no deadband crossover distortion, large output voltage swing, excellent phase and gain margins, low open loop high frequency output impedance and symmetrical source and sink AC frequency performance.

#### FEATURES

- \* Single (or dual) supply operation from +3 V to +36V ( $\pm 1.5V \sim \pm 18V$ )
- \* Large output voltage swing: +14.1V/-14.6V
- \* Input offset voltage trimmed to 100 $\mu$ V (Typ)
- \* Very low input bias current: 300nA
- \* Very low input offset current: 3.0nA
- \* High input resistance: 16M $\Omega$
- \* High slew rate: 10V/ $\mu$ s
- \* High gain bandwidth product: 24MHz @ 100kHz
- \* Low total harmonic distortion: 0.003%
- \* Power supply drain current: 2.15mA per amplifier
- \* Low noise: 18nV /  $\sqrt{\text{Hz}}$  @ 1.0kHz

#### ORDERING INFORMATION

Ordering Number		Package	Packing
Lead Free	Halogen Free		
MC33272L-S08-R	MC33272G-S08-R	SOP-8	Tape Reel

<p>MC33272G-S08-R</p> <ul style="list-style-type: none"> <li>(1) Packing Type</li> <li>(2) Package Type</li> <li>(3) Green Package</li> </ul>	<ul style="list-style-type: none"> <li>(1) R: Tape Reel</li> <li>(2) S08: SOP-8</li> <li>(3) G: Halogen Free and Lead Free, L: Lead Free</li> </ul>
---	---

#### MARKING

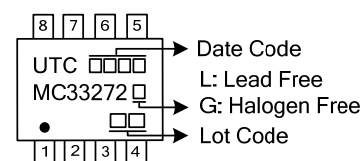

■ PIN CONFIGURATION

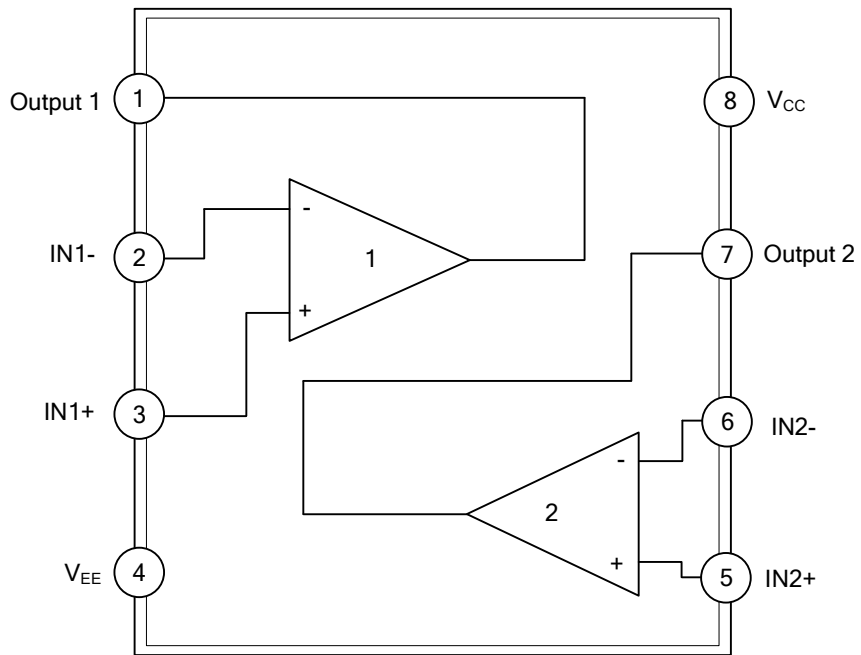

■ PIN DESCRIPTION

PIN NO.	PIN NAME	DESCRIPTION
1	Output 1	The output of channel 1
2, 3	IN1-, IN1+	The input of channel 1
4	$V_{EE}$	Power supply
5, 6	IN2+, IN2-	The input of channel 2
7	Output 2	The output of channel 2
8	$V_{CC}$	Power supply

FLYING 汎翔國際有限公司  
[www.flying1688.com](http://www.flying1688.com)

■ BLOCK DIAGRAM

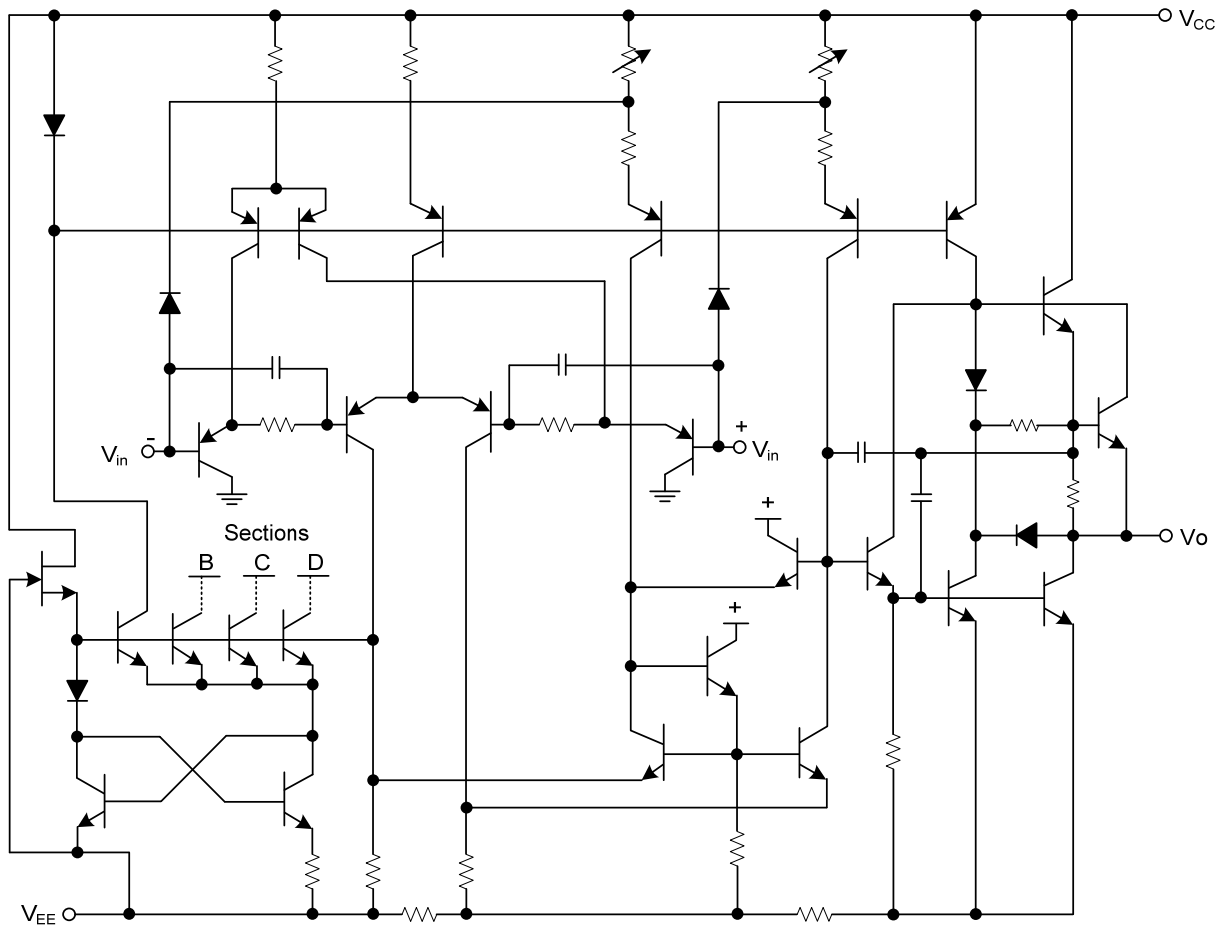

FLYING 汎翔國際有限公司  
www.flying1688.com

■ ABSOLUTE MAXIMUM RATING

PARAMETER	SYMBOL	RATINGS	UNIT
Supply Voltage	$V_{CC}$ to $V_{EE}$	+36	V
Input Differential Voltage Range	$V_{IDR}$	(Note 2)	V
Input Voltage Range	$V_{IR}$	(Note 2)	V
Output Short Circuit Duration (Note 3)	$t_{SC}$	Indefinite	sec
Maximum Power Dissipation	$P_D$	(Note 3)	mW
Maximum Junction Temperature	$T_J$	+150	°C
Operating Temperature Range	$T_{OPR}$	-40 ~ 85	°C
Storage Temperature	$T_{STG}$	-60~+150	°C

Notes: 1. Absolute maximum ratings are those values beyond which the device could be permanently damaged.

Absolute maximum ratings are stress ratings only and functional device operation is not implied.

2. Either or both input voltages must not exceed the magnitude of  $V_{CC}$  or  $V_{EE}$ .

3. Power dissipation must be considered to ensure maximum junction temperature ( $T_J$ ) is not exceeded.

■ DC ELECTRICAL CHARACTERISTICS ( $V_{CC}=+15$  V,  $V_{EE}=-15$  V,  $T_A=25^\circ$ C, unless otherwise noted.)

PARAMETER	SYMBOL	TEST CONDITIONS	MIN	TYP	MAX	UNIT			
Input Offset Voltage	$ V_{IO} $	$R_S=10\Omega$ , $V_{CC}=+15V$ , $V_{EE}=-15V$		0.1	1.0	mV			
		$V_{CM}=0V$ , $V_O=0V$ , $V_{CC}=5.0V$ , $V_{EE}=0$			2.0	mV			
Average Temperature Coefficient of Input Offset Voltage	$\Delta V_{IO}/\Delta T$	$R_S=10\Omega$ , $V_{CM}=0V$ , $V_O=0V$ , $T_A=-40^\circ$ C~+85°C		2.0		$\mu$ V/°C			
Input Bias Current	$I_{IB}$	$V_{CM}=0V$ , $V_O=0V$		300	650	nA			
Input Offset Current	$ I_{IO} $	$V_{CM}=0V$ , $V_O=0V$		3.0	65	nA			
Common Mode Input Voltage Range	$V_{ICR}$	$\Delta V_{IO}=5.0$ mV, $V_O=0V$	$V_{EE}$ to ( $V_{CC}-1.8$ )			V			
Large Signal Voltage Gain	$A_{VOL}$	$V_O=0V\sim 10V$ , $R_L=2.0$ k $\Omega$	90	100		dB			
Output Voltage Swing	$V_{O+}$	$V_{ID}=\pm 1.0V$	$V_{CC}=+15V$ , $V_{EE}=-15V$	$R_L=2.0$ k $\Omega$	13.4	13.9	V		
	$V_{O-}$			$R_L=2.0$ k $\Omega$		-13.9	-13.5	V	
	$V_{O+}$			$R_L=10$ k $\Omega$	13.4	14		V	
	$V_{O-}$			$R_L=10$ k $\Omega$		-14.7	-14.1	V	
	$V_{OL}$			$V_{CC}=5.0V$ , $V_{EE}=0V$	$R_L=2.0$ k $\Omega$			0.2	V
	$V_{OH}$			$R_L=2.0$ k $\Omega$	3.7		5.0	V	
Common Mode Rejection	CMR	$V_{in}=+13.2V\sim -15V$	80	100		dB			
Power Supply Rejection	PSR	$V_{CC}/V_{EE}=+15V/-15V$ , $+5.0V/-15V$ , $+15V/-5.0V$	80	105		dB			
Output Short Circuit Current	$I_{SC}$	$V_{ID}=1.0V$ , Output to Ground	Source	+25	+37	mA			
			Sink		-37	-25	mA		
Power Supply Current Per Amplifier	$I_{CC}$	$V_O=0V$	$V_{CC}=+15V$ , $V_{EE}=-15V$		2.15	2.75	mA		
			$V_{CC}=5.0V$ , $V_{EE}=0V$			2.75	mA		

■ AC ELECTRICAL CHARACTERISTICS ( $V_{CC}=+15\text{ V}$ ,  $V_{EE}=-15\text{ V}$ ,  $T_A=25^\circ\text{C}$ , unless otherwise noted.)

PARAMETER	SYMBOL	TEST CONDITIONS	MIN	TYP	MAX	UNIT
Slew Rate	SR	$V_{in}=-10\text{V}\sim+10\text{ V}$ , $R_L=2.0\text{k}\Omega$ , $C_L=100\text{pF}$ , $A_V=+1.0\text{V}$	8	10		V/ $\mu\text{s}$
Gain Bandwidth Product	GBW	$f=100\text{kHz}$	17	24		MHz
AC Voltage Gain	$A_{VO}$	$R_L=2.0\text{k}\Omega$ , $V_O=0\text{V}$ , $f=20\text{kHz}$		65		dB
Unity Gain Frequency	$f_U$	Open Loop		5.5		MHz
Gain Margin	$A_m$	$R_L=2.0\text{k}\Omega$ , $C_L=0\text{pF}$		12		dB
Phase Margin	$\phi_m$	$R_L=2.0\text{k}\Omega$ , $C_L=0\text{pF}$		55		Degrees
Channel Separation	CS	$f=20\text{Hz}\sim 20\text{kHz}$		-120		dB
Power Bandwidth	$BW_p$	$V_O=20\text{Vpp}$ , $R_L=2.0\text{k}\Omega$ , $\text{THD}\leq 1.0\%$		160		kHz
Total Harmonic Distortion	THD	$R_L=2.0\text{k}\Omega$ , $f = 20\text{Hz}\sim 20\text{kHz}$ , $V_O=3.0\text{V}_{\text{rms}}$ , $A_V=+1.0$		0.003		%
Open Loop Output Impedance	$ Z_O $	$V_O=0\text{V}$ , $f = 6.0\text{MHz}$		35		$\Omega$
Differential Input Resistance	$R_{IN}$	$V_{CM}=0\text{V}$		16		M $\Omega$
Differential Input Capacitance	$C_{IN}$	$V_{CM}=0\text{V}$		3		pF
Equivalent Input Noise Voltage	$e_n$	$R_S=100\Omega$ , $f = 1.0\text{kHz}$		18		nV/ $\sqrt{\text{Hz}}$
Equivalent Input Noise Current	$i_n$	$f=1.0\text{kHz}$		0.5		pA/ $\sqrt{\text{Hz}}$

UTC assumes no responsibility for equipment failures that result from using products at values that exceed, even momentarily, rated values (such as maximum ratings, operating condition ranges, or other parameters) listed in products specifications of any and all UTC products described or contained herein. UTC products are not designed for use in life support appliances, devices or systems where malfunction of these products can be reasonably expected to result in personal injury. Reproduction in whole or in part is prohibited without the prior written consent of the copyright owner. The information presented in this document does not form part of any quotation or contract, is believed to be accurate and reliable and may be changed without notice.