



OPA2336

Preliminary

CMOS IC

SINGLE-SUPPLY, MICROPOWER CMOS OPERATIONAL AMPLIFIERS

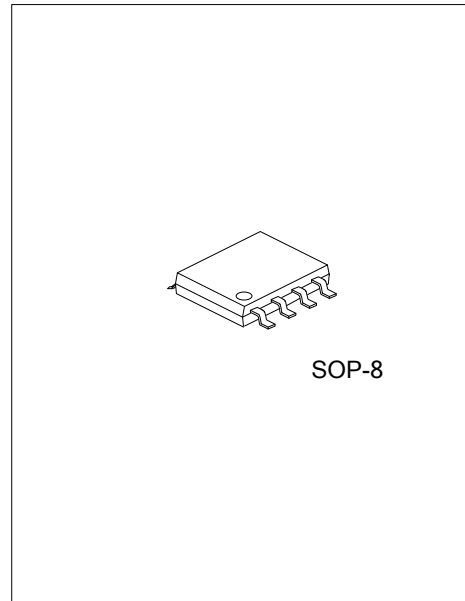

DESCRIPTION

The UTC **OPA2336** is a CMOS operational amplifier. It is operated on a 2.1V (Min.) single supply. A100kΩ load is driven by the rail-to-rail output and the accuracy of the output voltage is ensured at ± 3mV.

The UTC **OPA2336** is characterized by its low quiescent current (20μA/amplifier), low offset voltage (125μV max), low input bias current (1pA), and high open-loop gain (115dB).

The UTC **OPA2336** features completely independent circuitry for lowest crosstalk and freedom from interaction.

The UTC **OPA2336** is particularly designed for battery-powered applications and the common-mode range extending to the negative supply makes it ideal for single-supply applications.

In addition to the applications mentioned above, the UTC **OPA2336** is suitable for portable devices, high-Impedance applications, photodiode, pre-amps, precision integrators, medical instruments, and test equipment.

FEATURES

- * Operating on a Single-Supply
- * Rail-to-Rail Output (Accuracy: ± 3mv)
- * Low Power Dissipation: I_Q=20μA/Amplifier
- * Low Offset Voltage up to 125μV (MAX.)
- * Power Supply Specified from 2.3V to 5.5V

ORDERING INFORMATION

Ordering Number		Package	Packing
Lead Free	Halogen Free		
OPA2336G-S08-R	OPA2336G-S08-R	SOP-8	Tape Reel

<p>OPA2336G-S08-R</p> <p>(1)Packing Type (2)Package Type (3)Green Package</p>	<p>(1) R: Tape Reel (2) S08: SOP-8 (3) G: Halogen Free and Lead Free, L: Lead Free</p>
---	--

MARKING

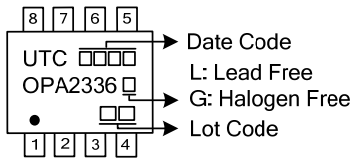

PIN CONFIGURATION

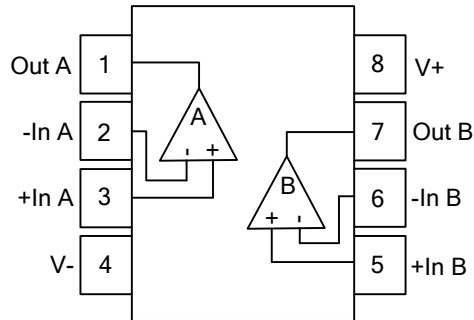

PIN DESCRIPTION

PIN NO.	PIN NAME	DESCRIPTION
1	OUTA	Output of channel A
2	-In A	Negative Input of channel A
3	+In A	Positive Input of channel A
4	V-	Ground
5	+In B	Positive Input of channel B
6	-in B	Negative Input of channel B
7	Out B	Output of channel B
8	V+	Power supply

汎翔國際有限公司
 www.flying1688.com

■ ABSOLUTE MAXIMUM RATING

PARAMETER	SYMBOL	RATINGS	UNIT
Supply Voltage	V_S	7.5	V
Signal Input Terminals Voltage (Note 2)	V_{IT}	$(V_-)-0.3\sim(V_+)+0.3$	V
Signal Input Terminals Current (Note 2)	I_{IT}	10	mA
Output Short-Circuit (Note 3)	I_{OS}	Continuous	A
Operating Junction Temperature	T_{OPR}	-40~ +125	°C
Storage Temperature	T_{STG}	-55~ +125	°C

Note: 1. Absolute maximum ratings are those values beyond which the device could be permanently damaged.

Absolute maximum ratings are stress ratings only and functional device operation is not implied.

2. Input terminals are diode-clamped to the power supply rails. Input signals that can swing more than 0.3V beyond the supply rails should be current-limited to 10mA or less.

3. Short-circuit to ground, one amplifier per package.

■ THERMAL DATA

PARAMETER	SYMBOL	RATINGS	UNIT
Junction to Ambient	θ_{JA}	150	°C/W

■ ELECTRICAL CHARACTERISTICS

(At $T_A=+25^\circ\text{C}$, $V_S=+5\text{V}$, $R_L=25\text{k}\Omega$ connected to $V_S/2$, unless otherwise specified.)

PARAMETER	SYMBOL	TEST CONDITIONS	MIN	TYP	MAX	UNIT
OFFSET VOLTAGE						
Input Offset Voltage	$V_{I(OFF)}$			±60	±125	μV
Input Offset Voltage vs. Temperature	dV_{OS}/dT			±1.5		μV/°C
Input Offset Voltage vs. Power Supply	PSRR	$V_S = 2.3\text{V} \sim 5.5\text{V}$		25	100	μV/V
Over Temperature		$V_S = 2.3\text{V} \sim 5.5\text{V}$			130	μV/V
Channel Separation, DC				0.1		μV/V
INPUT BIAS CURRENT						
Input Bias Current	I_{BIAS}			±1	±10	pA
Over Temperature					±60	pA
Input Offset Current	$I_{O(OFF)}$			±1	±10	pA
NOISE						
Input Voltage Noise, $f = 0.1 \sim 10\text{Hz}$				3		μV _{P-P}
Input Voltage Noise Density, $f = 1\text{kHz}$	e_N			40		nV/√Hz
Current Noise Density, $f = 1\text{kHz}$	i_N			30		fA/√Hz
INPUT VOLTAGE RANGE						
Common-Mode Voltage Range	V_{CM}		-0.2		$(V_+)-1$	V
Common-Mode Rejection Ratio	CMRR	$-0.2\text{V} < V_{CM} < (V_+)-1\text{V}$	80	90		dB
Over Temperature		$-0.2\text{V} < V_{CM} < (V_+)-1\text{V}$	76			dB
INPUT IMPEDANCE						
Differential				$10^{13} 2$		Ω pF
Common-Mode	CM			$10^{13} 4$		Ω pF
OPEN-LOOP GAIN						
Open-Loop Voltage Gain	A_{OL}	$R_L=25\text{k}\Omega$, $100\text{mV} < V_{OUT} < (V_+)-100\text{mV}$	100	115		dB
Over Temperature		$R_L=25\text{k}\Omega$, $100\text{mV} < V_{OUT} < (V_+)-100\text{mV}$	100			dB
Open-Loop Voltage Gain	A_{OL}	$R_L=5\text{k}\Omega$, $500\text{mV} < V_{OUT} < (V_+)-500\text{mV}$	90	106		dB
Over Temperature		$R_L=5\text{k}\Omega$, $500\text{mV} < V_{OUT} < (V_+)-500\text{mV}$	90			dB

■ ELECTRICAL CHARACTERISTICS(Cont.)

FREQUENCY RESPONSE						
Gain-Bandwidth Product	GBW	$V_S=5V, G=1$		100		kHZ
Slew Rate	SR	$V_S=5V, G=1$		0.03		V/ μ s
Overload Recovery Time		$V_{IN} \cdot G = V_S$		100		μ s
OUTPUT						
Voltage Output Swing from Rail (Note 2)	V_{OS}	$R_L=100k\Omega, A_{OL}\geq 70dB$		3		mV
Voltage Output Swing from Rail (Note 2)		$R_L=25k\Omega, A_{OL}\geq 90dB$		20	100	mV
Over Temperature		$R_L=25k\Omega, A_{OL}\geq 90dB$			100	mV
Voltage Output Swing from Rail (Note 2)		$R_L=5k\Omega, A_{OL}\geq 90dB$		70	500	mV
Over Temperature		$R_L=5k\Omega, A_{OL}\geq 90dB$			500	mV
Short-Circuit Current	I_{SC}			± 5		mA
Capacitive Load Drive	C_{LOAD}					pF
POWER SUPPLY						
Specified Voltage Range	V_S		2.3		5.5	V
Minimum Operating Voltage				2.1		V
Quiescent Current (Per Amplifier)	I_Q	$I_{OUT}=0$		20	32	μ A
Over Temperature		$I_{OUT}=0$			36	μ A
TEMPERATURE RANGE						
Specified Range			-40		+85	$^{\circ}$ C
Operating Range			-55		+125	$^{\circ}$ C
Storage Range			-55		+125	$^{\circ}$ C

Note: 1. $V_S = +5V$.

2. Output voltage swings are measured between the output and positive and negative power-supply rails.

■ APPLICATION INFORMATION

The UTC **OPA2336** is a CMOS operational amplifier, its outstanding features and functions make it suitable for several applications. The UTC **OPA2336** is unity-gain stable and can be protected under the reverse battery voltages conditions. 0.01 μ F ceramic capacitors are required to bypass the power supply.

OPERATING VOLTAGE

The UTC **OPA2336** is operating on a single supply ranging from 2.1V to +5.5V, most behavior remains unchanged throughout the full operating voltage range. The UTC **OPA2336** is fully specified for operation from +2.3V to +5.5V; a single limit applies over the supply range. Moreover, this device performs well over a temperature range of -40°C to +85°C.

INPUT VOLTAGE

The UTC **OPA2336** allows input common-mode range varies from (V₋)-0.2V to (V₊)-1V, normal behaviors should operate within this range. In addition, the absolute maximum input voltage is 300mV beyond the supplies. Thus, inputs greater than the input common-mode range but less than maximum input voltage, while not valid, will not cause any damage to the op-amp.

Normally, input bias current is approximately 1pA. However, the input pin may be applied to an excess inrush current, which is encountered when input voltages are higher than the power supplies. This device is not damaged unless the current on the input pins is less than 10mA. This is easily accomplished with an input resistor, as shown in **Figure 1**.

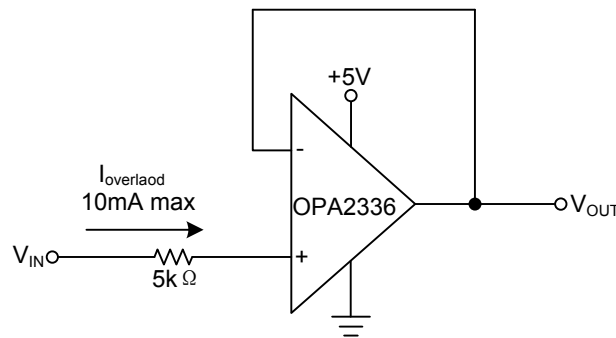

Figure 1. Input Current Protection for Voltages Exceeding the Supply Voltage

CAPACITIVE LOAD AND STABILITY

The UTC **OPA2336** under certain conditions may become unstable. For device's stability, there are many factors considered besides the amplifier gain, load value and so on.

The UTC **OPA2336** can drive a wide range of capacitive loads, it can drive approximately 10,000pF when properly configured. An op amp in unity-gain configuration is the most vulnerable to capacitive load. The capacitive load reacts with the op amp's output resistance, along with any additional load resistance, to create a pole in the response which degrades the phase margin. In unity gain, 300pF capacitive load is to be optimal for the UTC **OPA2336**. Increasing gain enhances the amplifier's ability to drive loads beyond this level.

In order to improve capability of driving capacitive load in the unity-gain configuration, a 50 Ω to 100 Ω resistor is expected to locate inside the feedback loop, as shown in **Figure 2**. This reduces ringing with large capacitive loads while maintaining DC accuracy.

■ APPLICATION INFORMATION (Cont.)

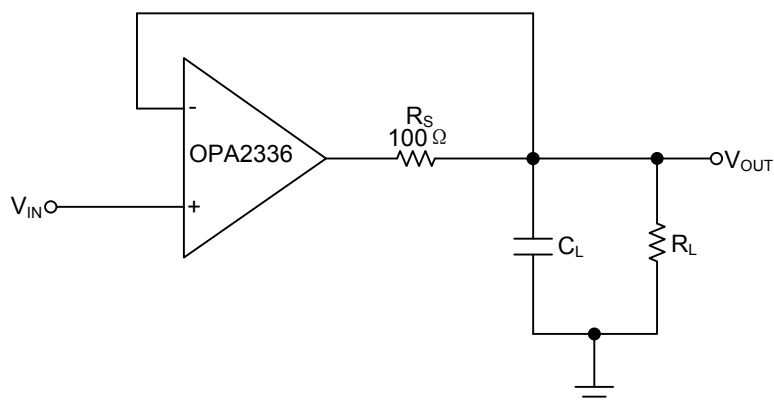

Figure 2. Series Resistor in Unity-Gain Configuration Improves Capacitive Load Drive

The resistor can be also located in series with the output outside of the feedback loop, if paralleling a resistive load to the capacitive load, a voltage divider is generated with it. This introduces a Direct Current (DC) error at the output, however, this error may be insignificant. For instance, with $R_L = 100\text{k}\Omega$ and $R_S = 100\Omega$, there is only about a 0.1% error at the output.

UTC assumes no responsibility for equipment failures that result from using products at values that exceed, even momentarily, rated values (such as maximum ratings, operating condition ranges, or other parameters) listed in products specifications of any and all UTC products described or contained herein. UTC products are not designed for use in life support appliances, devices or systems where malfunction of these products can be reasonably expected to result in personal injury. Reproduction in whole or in part is prohibited without the prior written consent of the copyright owner. The information presented in this document does not form part of any quotation or contract, is believed to be accurate and reliable and may be changed without notice.