

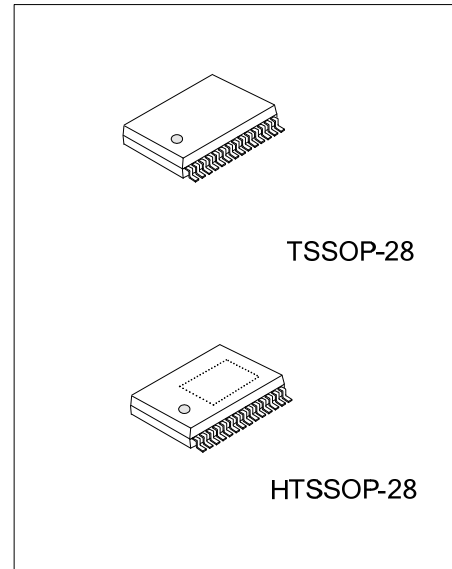

PA4838

CMOS IC

STEREO 2W AUDIO POWER AMPLIFIERS WITH DC VOLUME CONTROL AND SELECTABLE GAIN



DESCRIPTION

The UTC **PA4838** is a monolithic integrated circuit and designed to provide DC volume control with minimum amount of external components, and stereo bridged audio power amplifiers capable of producing 2W into 4Ω or 2.2W into 3Ω with less than 1.0% THD.

The UTC **PA4838** incorporates a DC volume control, stereo bridged audio power amplifiers and a selectable gain or bass boost, making it optimally suitable for multimedia monitors, portable radios, desk top, and other portable applications.

The UTC **PA4838** features an externally controlled, low-power consumption shutdown mode, and both a power amplifier and headphone mute for maximum system flexibility and performance.

FEATURES

- * DC Volume Control Interface
- * System Beep Detect
- * Stereo switchable bridged/single-ended power amplifiers
- * Selectable internal/external gain and bass boost
- * "Click and pop" suppression circuitry
- * Thermal shutdown protection

ORDERING INFORMATION

Ordering Number		Package	Packing
Lead Free	Halogen Free		
PA4838L-P28-R	PA4838G-P28-R	TSSOP-28	Tape Reel
PA4838L-N28-R	PA4838G-N28-R	HTSSOP-28	Tape Reel

<p>PA4838G-P28-R</p> <ul style="list-style-type: none"> (1) Packing Type (2) Package Type (3) Green Package 	<ul style="list-style-type: none"> (1) R: Tape Reel (2) R28: TSSOP-28, N28: HTSSOP-28 (3) G: Halogen Free and Lead Free, L: Lead Free
--	--

MARKING

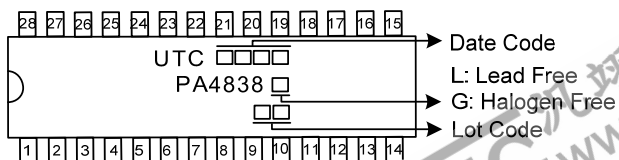

■ PIN CONFIGURATION

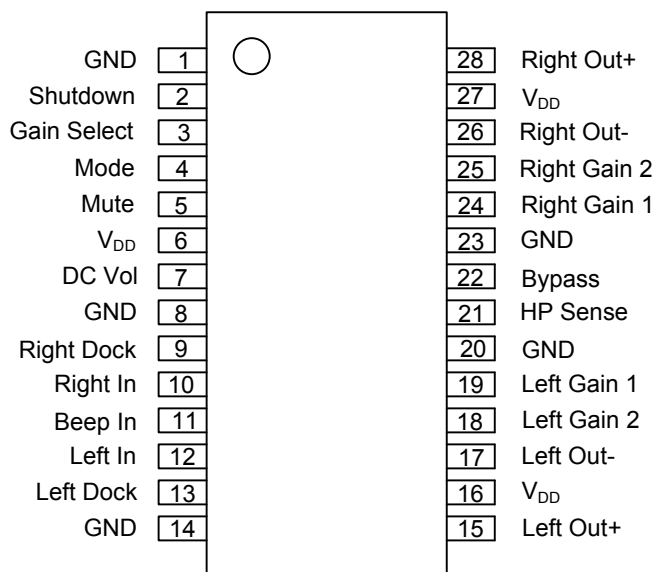

■ PIN DESCRIPTION

PIN NO	PIN NAME	I/O	DESCRIPTION
1, 8, 14, 20, 23	GND		Power ground
2	Shutdown	I	Shutdown mode control input, high active. Place PA4838 into shutdown mode, when held high
3	Gain Select	I	Gain select input. Applying to V_{DD} select the external gain mode. Applying 0V to this pin selects the internally set unit gain.
4	Mode	I	Mode select input. Mode 0, selected by applying 0V to this pin forces the PA4838 to effectively function as a line-out unity-gain amplifier. Mode 1, apply V_{DD} to mode pin to use the internal DC control volume. At mode1, the amplifier gain accords to the DC voltage applied to the DC Vol pin. DO NOT let the mode pin float.
5	Mute	I	Mute input, active high. Muting the amplifier and DOCK outputs when held high. DO NOT let the mute pin float.
6, 16, 27	V_{DD}		Power supply
7	DC Vol	I	Internal stereo volume control input, the setting is a function of DC voltage applied to this pin.
9	Right Dock	O	Output of the right side internal amplifier which drive the volume control input.
10	Right In	I	Input of the right side internal amplifier
11	Beep In	I	Beep signal input, a mono input that accepts the beep signal to accommodate system alert signal.
12	Left In	I	Input of the left side internal amplifier
13	Left Dock	O	Output of the left side internal amplifier which drive the volume control input.
15	Left Out+	O	Left side speaker output high
17	Left Out-	O	Left side speaker output low
18	Left Gain2	I	Connect to resistor can adjust the differential gain of the left side output stage
19	Left Gain1	I	Connect to resistor can adjust the differential gain of the left side output stage
21	HP Sense	I	Headphone control input, applying a voltage between 4V and V_{DD} can turn off the amps that drive the "Left Out+" & "Right Out+" pins.
22	Bypass	I	Connecting a capacitor for low noise performance and high PSRR.
24	Right Gain1	I	Connect to resistor can adjust the differential gain of the right side output stage
25	Right Gain2	I	Connect to resistor can adjust the differential gain of the right side output stage
26	Right Out+	O	Right side speaker output high
28	Right Out-	O	Right side speaker output low

■ BLOCK DIAGRAM

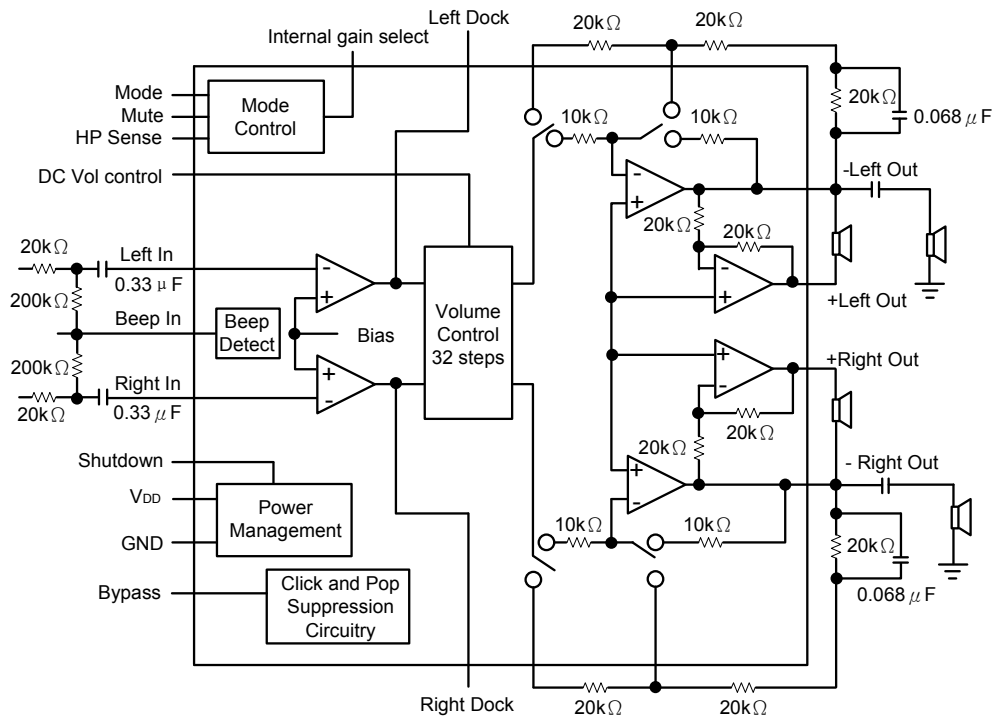

FLYING 汎翔國際有限公司
www.flying1688.com

■ ABSOLUTE MAXIMUM RATINGS

PARAMETER	SYMBOL	RATINGS	UNIT
Supply Voltage	V_{DD}	6.0	V
Supply Voltage(Recommended Operating Range)	V_{DD}	2.7 ~ 5.5V	V
Input Voltage	V_{IN}	-0.3 ~ $V_{DD}+0.3$	V
Power Dissipation	P_D	Internally limited	
Junction Temperature	T_J	+150	
Operation Temperature (T_a)	T_{OPR}	-40 ~ +85	
Storage Temperature	T_{STG}	-40 ~ +150	

Note: Absolute maximum ratings are those values beyond which the device could be permanently damaged. Absolute maximum ratings are stress ratings only and functional device operation is not implied.

■ THERMAL DATA

PARAMETER	SYMBOL	RATINGS	UNIT	
$V_{Thermal}$ Resistance	TSSOP-28	θ_{JA}	105	°C/W
	HTSSOP-28		93	°C/W
	TSSOP-28	θ_{JC}	10	°C/W
	HTSSOP-28		15	°C/W

Note: The θ_{JA} of HTSSOP is given that exposed die attach pad is not soldered on PCB.

■ ELECTRICAL CHARACTERISTICS ($V_{DD}=5V$, $T_a=25^\circ C$, unless otherwise specified.)

PARAMETER	SYMBOL	TEST CONDITIONS	MIN	TYP	MAX	UNIT
ENTIRE IC						
Supply Voltage	V_{DD}		2.7		5.5	V
Headphone Sense High Input Voltage	V_{IH}		4			V
Headphone Sense Low Input Voltage	V_{IL}				0.8	V
Quiescent Power Supply Current	I_{DD}	$V_{IN}=0V$, $I_{OUT}=0A$		15	30	mA
Shutdown Current	I_{SD}	$V_{SHUTDOWN}=V_{DD}$		0.7	2.0	μA
VOLUME ATTENUATORS						
Attenuator Range	C_{RANGE}	Gain with $V_{DCVOL}=5V$, No Load			± 0.75	dB
		Attenuation with $V_{DCVOL}=0V$ (BM & SE)	-75			dB
Mute Attenuation	A_M	$V_{MUTE}=5V$, Bridged Mode (BM)	-78			dB
		$V_{MUTE}=5V$, Single-Ended Mode (SE)	-78			dB
SINGLE-ENDED MODE OPERATION						
Output Power	P_{OUT}	THD=1.0%, f=1kHz, $R_L=32\Omega$		85		mW
		THD=10%, f=1kHz, $R_L=32\Omega$		95		mW
Total Harmonic Distortion + Noise	THD+N	$V_{OUT}=1V_{RMS}$, f=1kHz, $R_L=10k\Omega$, $A_{VD}=1$		0.065		%
Power Supply Rejection Ratio	PSRR	$C_B=1.0\mu F$, f=120Hz, $V_{RIPPLE}=200mV_{rms}$		58		dB
Channel Separation	X_{TALK}	f=1kHz, $C_B=1.0\mu F$		65		dB
Signal to Noise Ratio	SNR	$P_{OUT}=75mW$, $R_L=32\Omega$, A-Wtd Filter		102		dB

■ ELECTRICAL CHARACTERISTICS(Cont.)

PARAMETER	SYMBOL	TEST CONDITIONS	MIN	TYP	MAX	UNIT
BRIDGED MODE OPERATION						
Output Offset Voltage	V_{OS}	$V_{IN}=0V$, No Load	-50	5	+50	mV
Output Power	P_{OUT}	THD+N=1.0%, f=1kHz, $R_L=3\Omega$		2.2		W
		THD+N=1.0%, f=1kHz, $R_L=4\Omega$		2		W
		THD=1%(max), f=1kHz, $R_L=8\Omega$	1.0	1.1		W
		THD+N=10%, f=1kHz, $R_L=8\Omega$		1.5		W
Total Harmonic Distortion+ Noise	THD+N	$P_{OUT}=1W$, $R_L=8\Omega$, $A_{VD}=2$, 20Hz<f<20kHz		0.3		%
		$P_{OUT}=340mW$, $R_L=32\Omega$		1.0		%
Power Supply Rejection Ratio	PSRR	$C_B=1.0\mu F$, f=120Hz, $V_{RIPPLE}=200mV_{rms}$ $R_L=8\Omega$		74		dB
Channel Separation	X_{TALK}	F=1kHz, $C_B=1.0\mu F$		70		dB
Signal to Noise Ratio	SNR	$V_{DD}=5V$, $P_{OUT}=1.1W$, $R_L=8\Omega$ A -Wtd Filter		93		dB

■ TRUTH TABLE FOR LOGIC INPUTS

Gain Sel	Mode	Headphone Sense	Mute	Shutdown	Output Stage Set To	DC Volume	Output Stage Configuration
0	0	0	0	0	Internal Gain	Fixed	BTL
0	0	1	0	0	Internal Gain	Fixed	SE
0	1	0	0	0	Internal Gain	Adjustable	BTL
0	1	1	0	0	Internal Gain	Adjustable	SE
1	0	0	0	0	External Gain	Fixed	BTL
1	0	1	0	0	External Gain	Fixed	SE
1	1	0	0	0	External Gain	Adjustable	BTL
1	1	1	0	0	External Gain	Adjustable	SE
X	X	X	1	0	Muted	X	Muted
X	X	X	X	1	Shutdown	X	X

Note: If system beep is detected on the Beep In pin, the system beep will be passed through the bridged amplifier regardless of the logic of the Mute and HP sense pins.

■ TYPICAL APPLICATION CIRCUIT

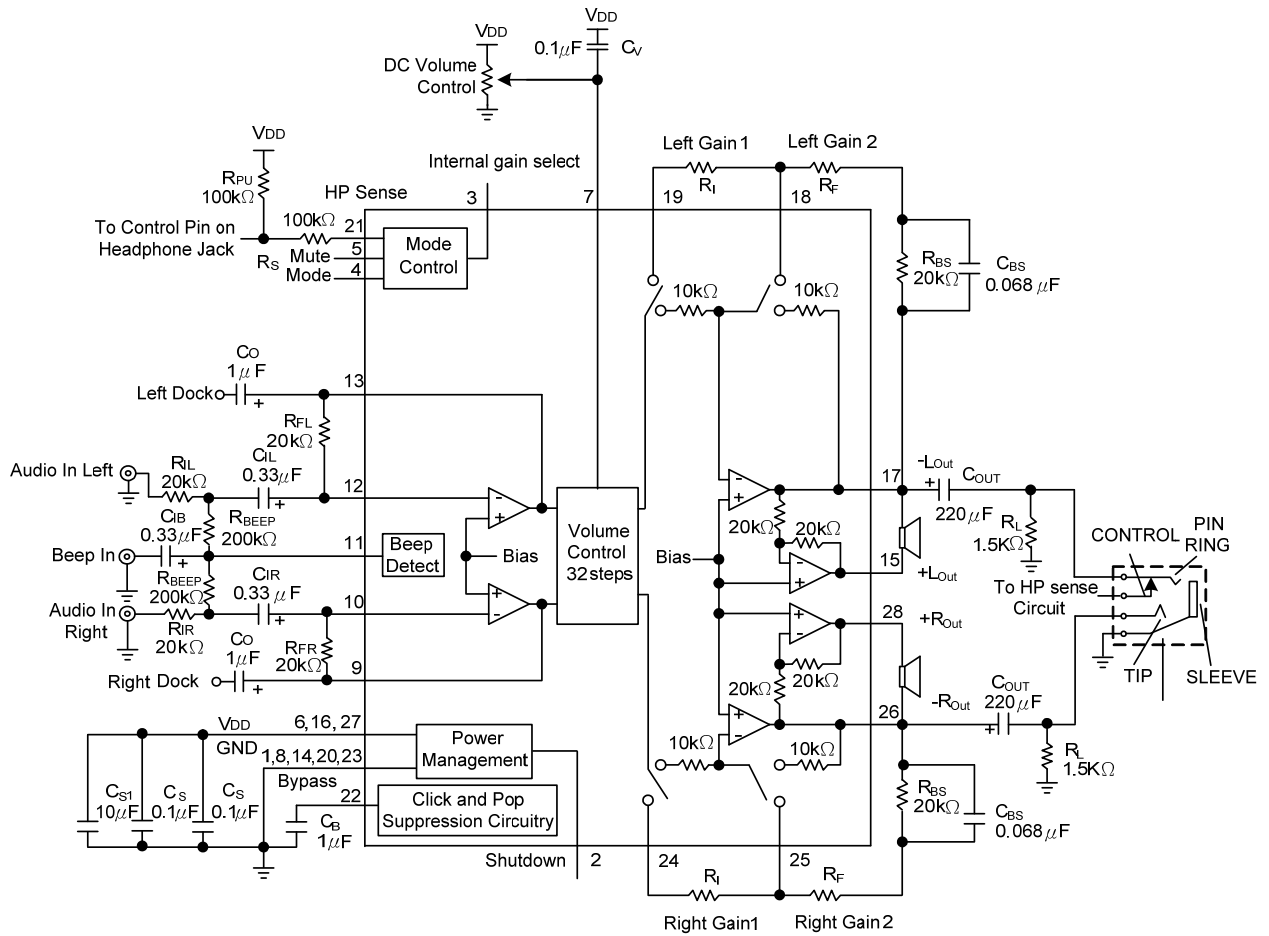

TYPICAL CHARACTERISTICS

For HTSSOP-28

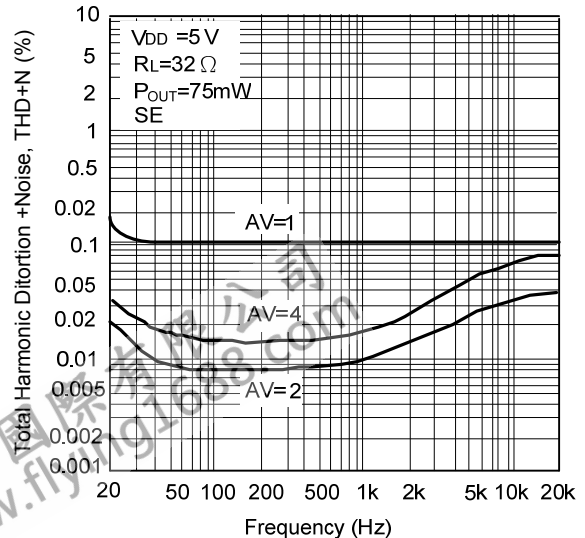
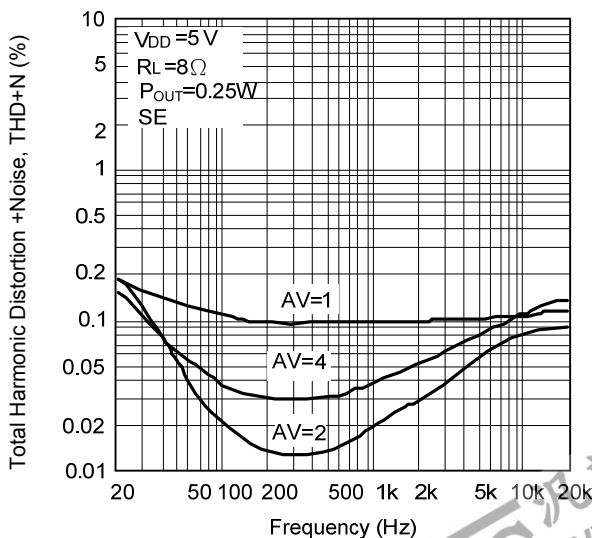
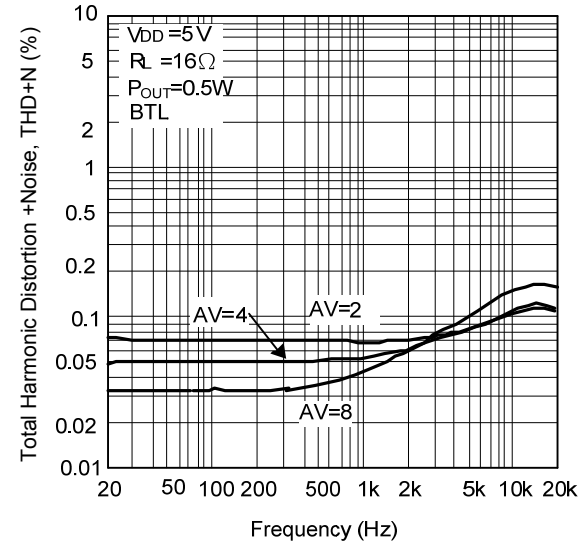
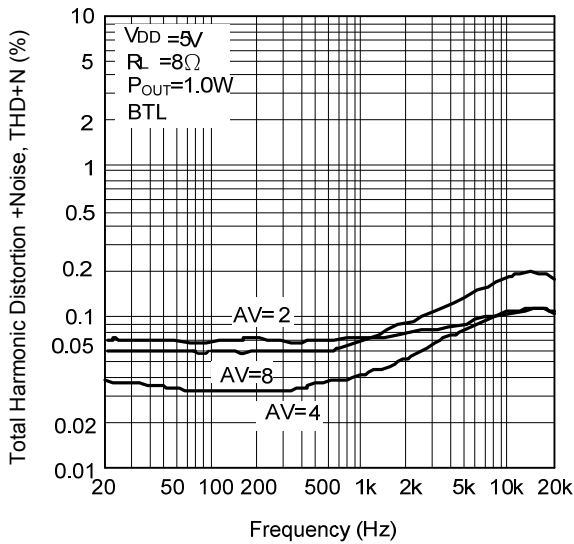
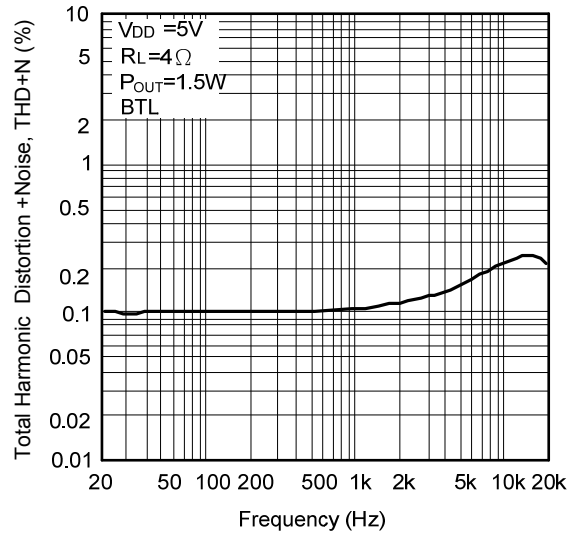
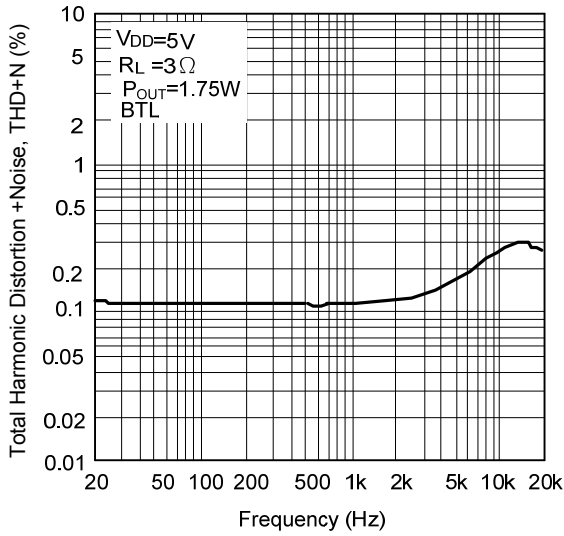

■ TYPICAL CHARACTERISTICS (Cont.)

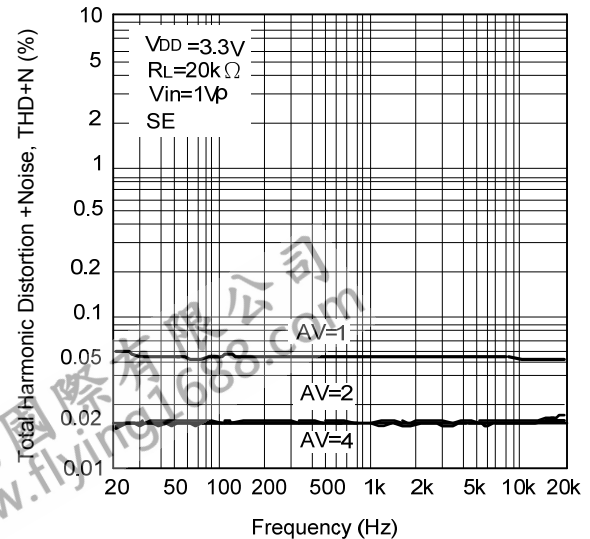
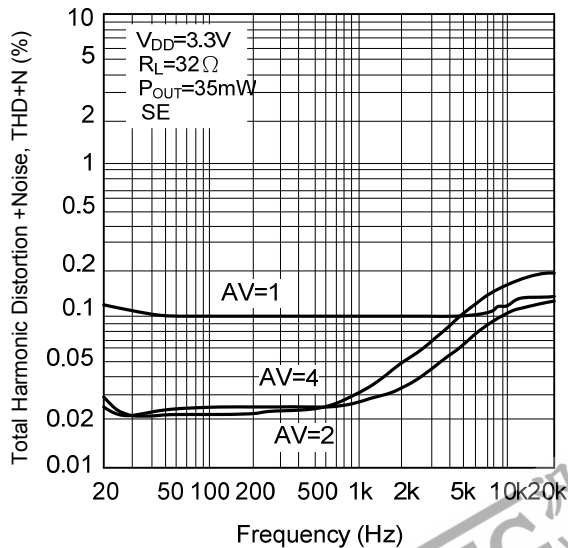
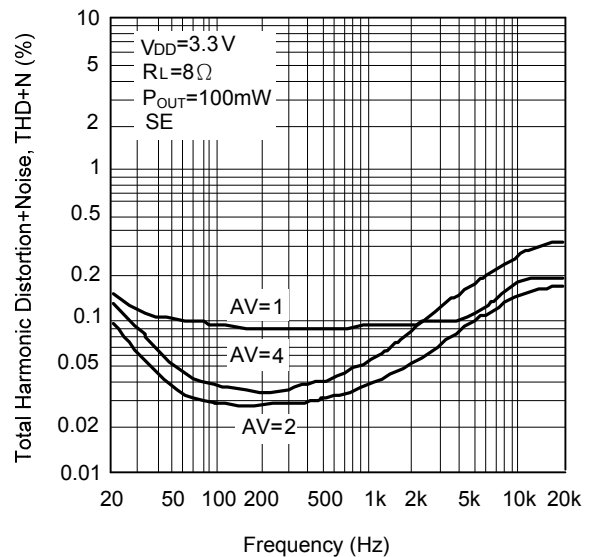
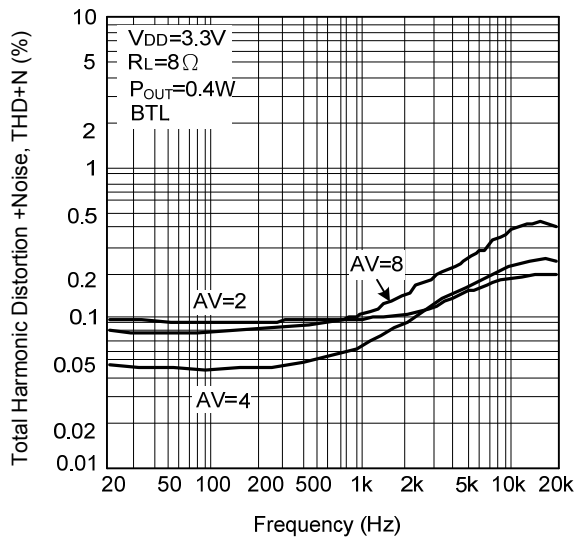
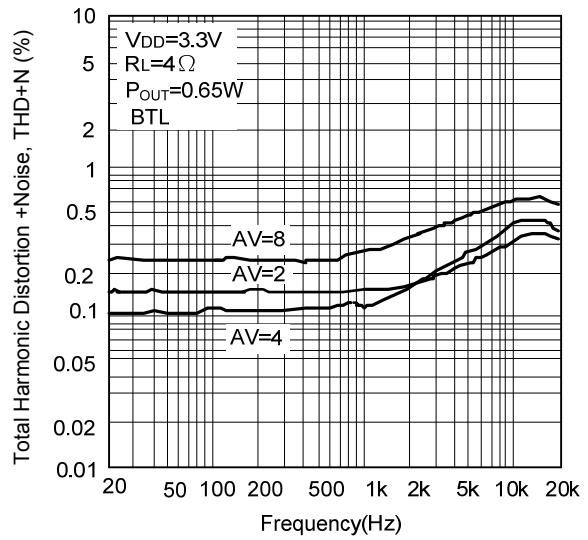
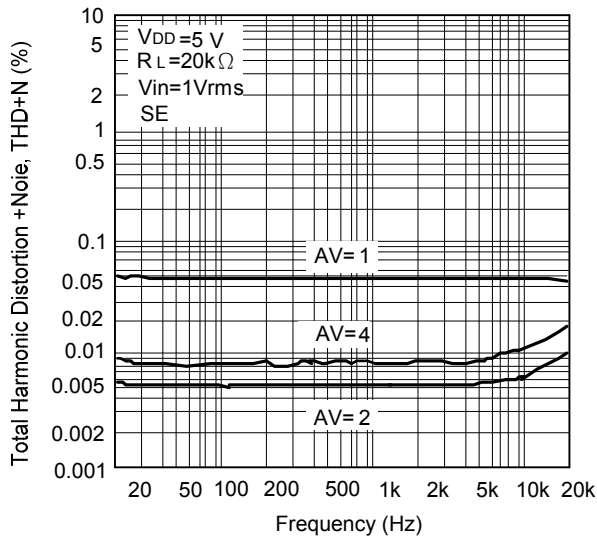

■ TYPICAL CHARACTERISTICS (Cont.)

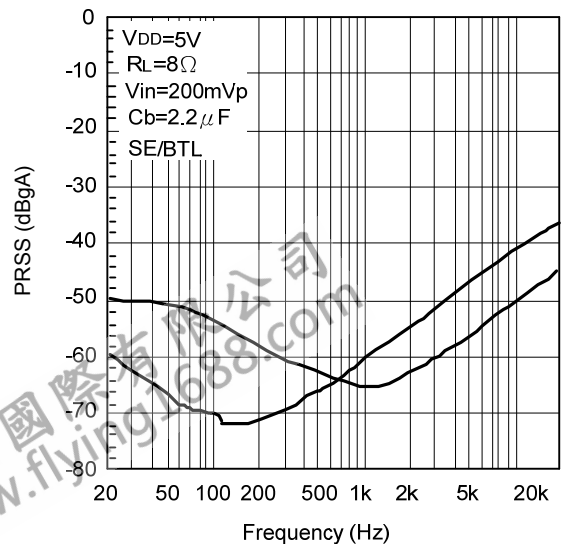
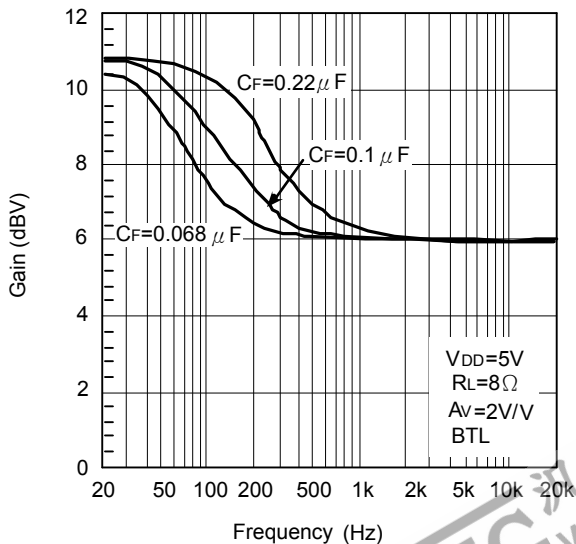
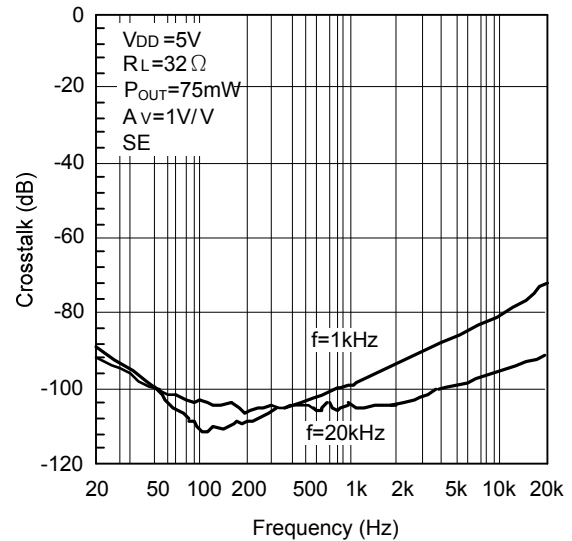
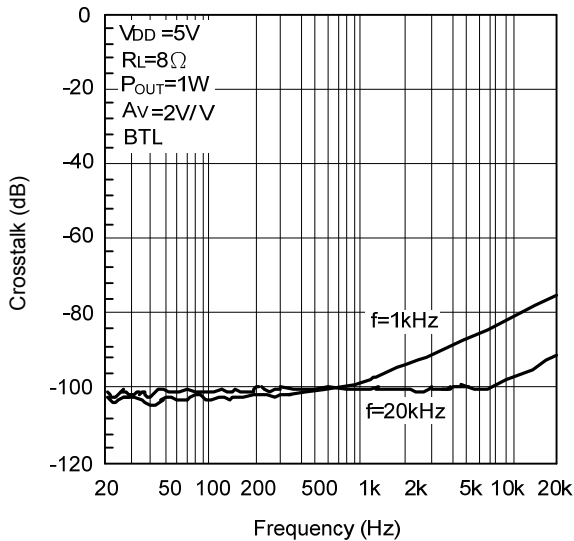
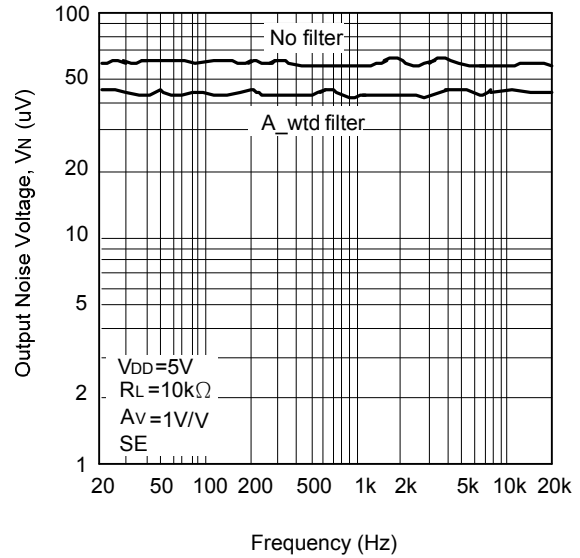
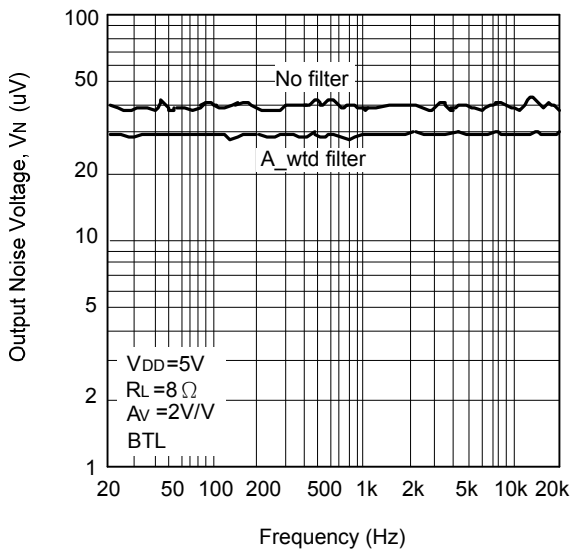

■ TYPICAL CHARACTERISTICS (Cont.)

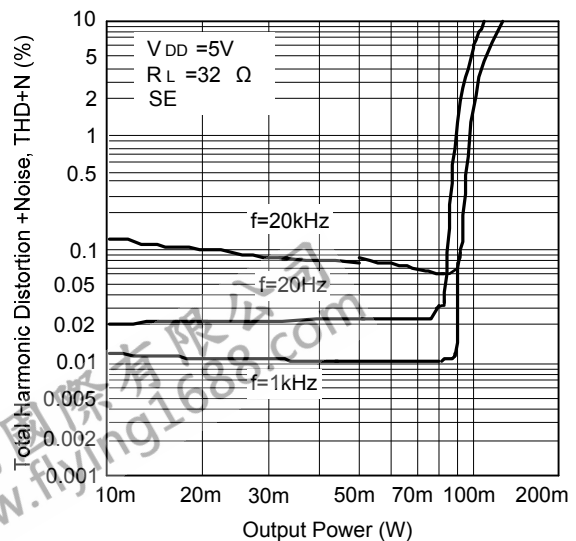
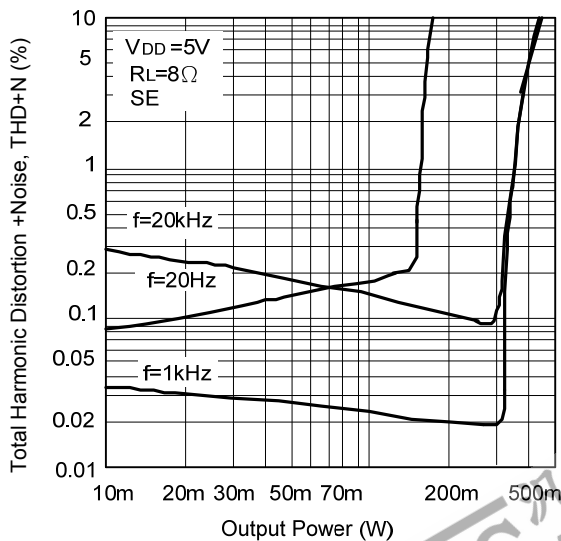
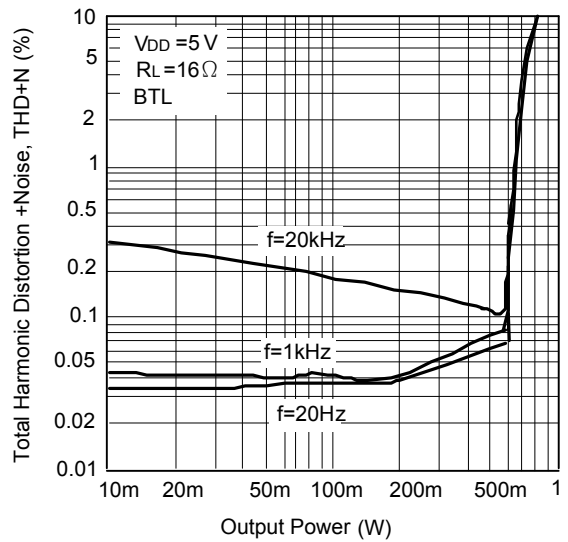
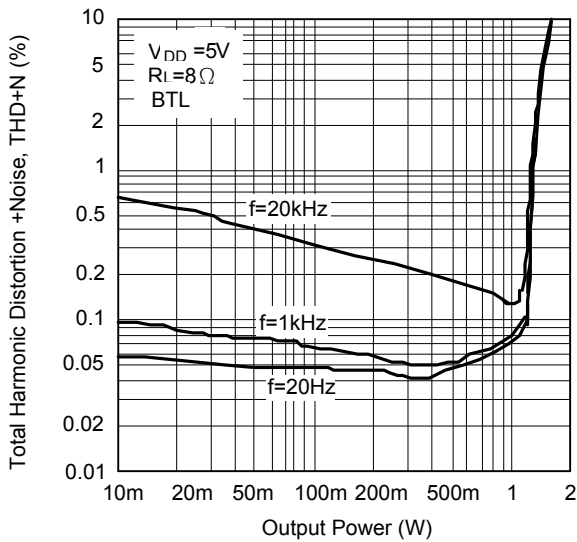
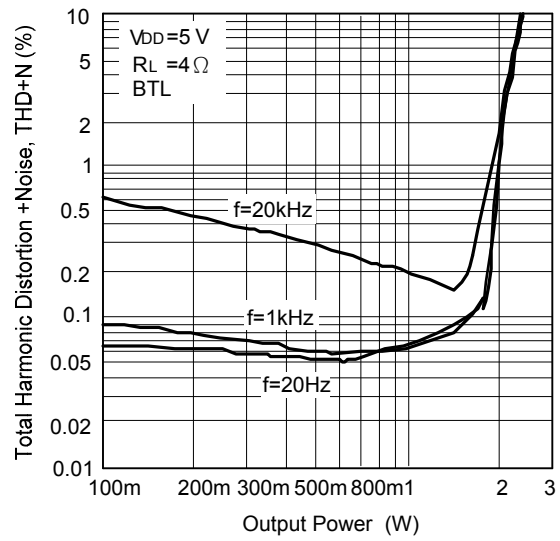
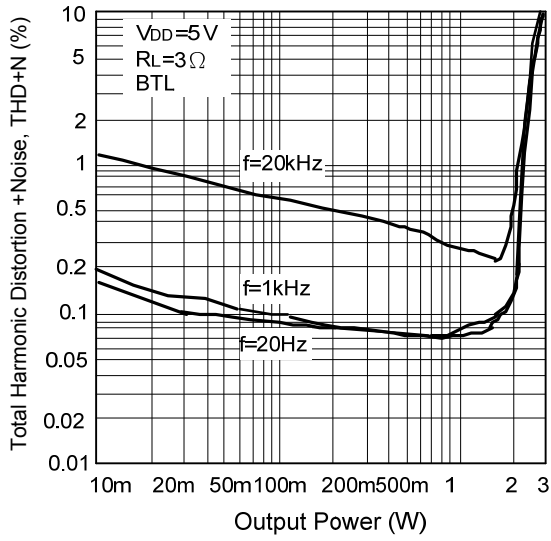

■ TYPICAL CHARACTERISTICS (Cont.)

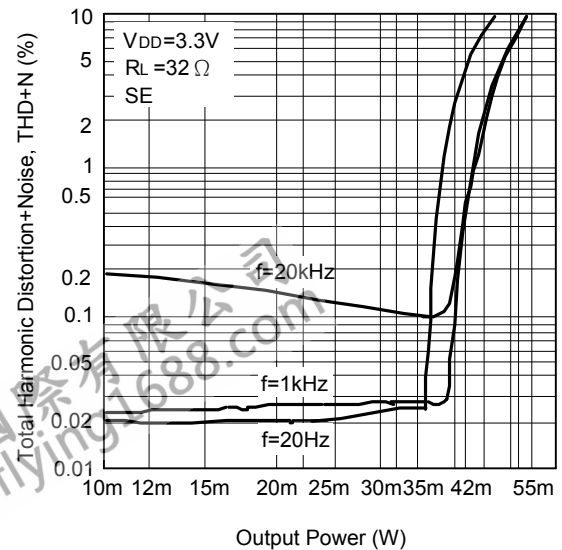
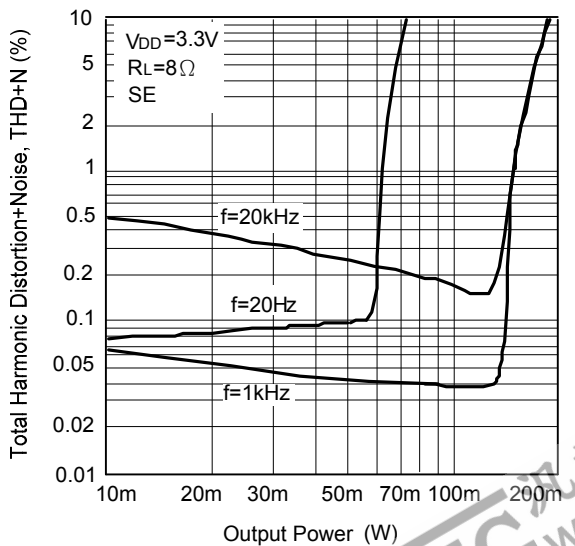
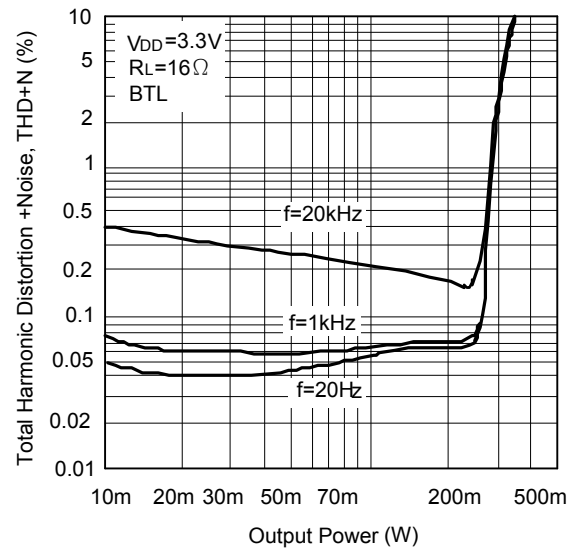
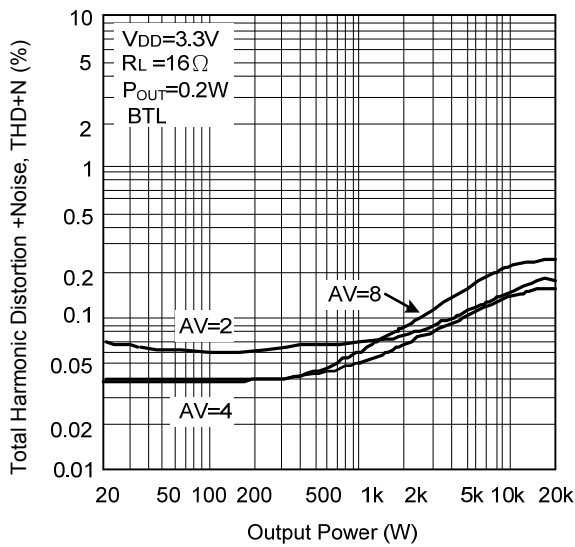
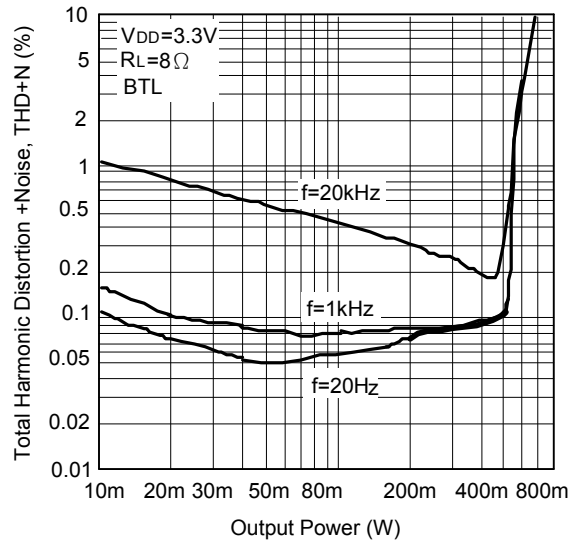
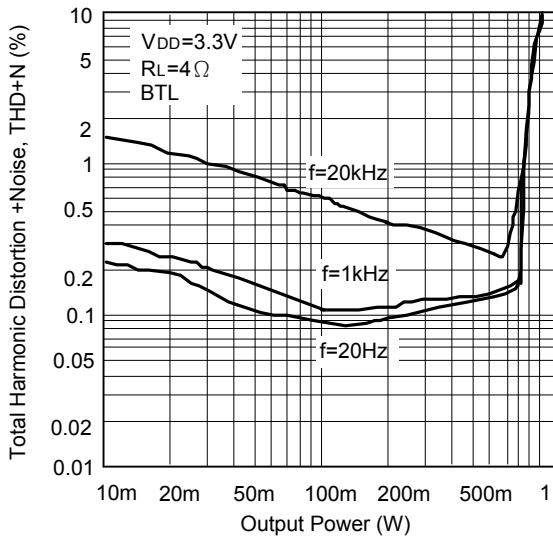

■ TYPICAL CHARACTERISTICS (Cont.)

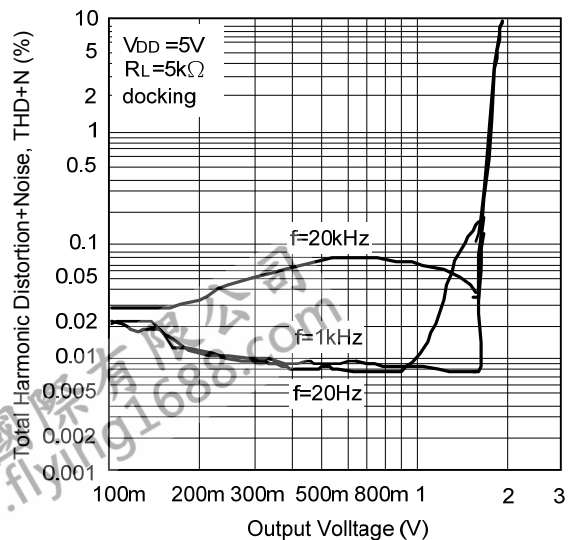
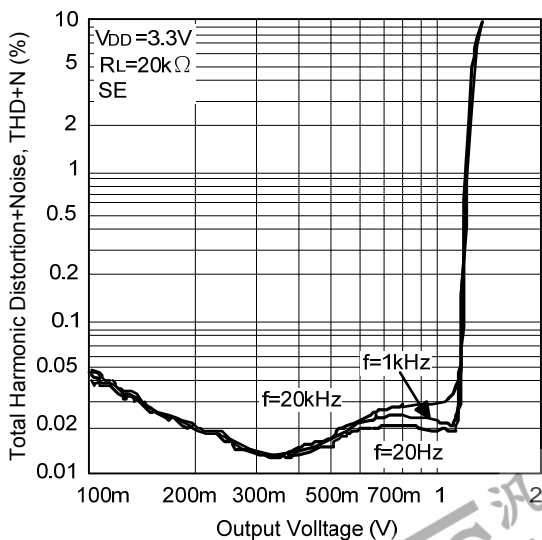
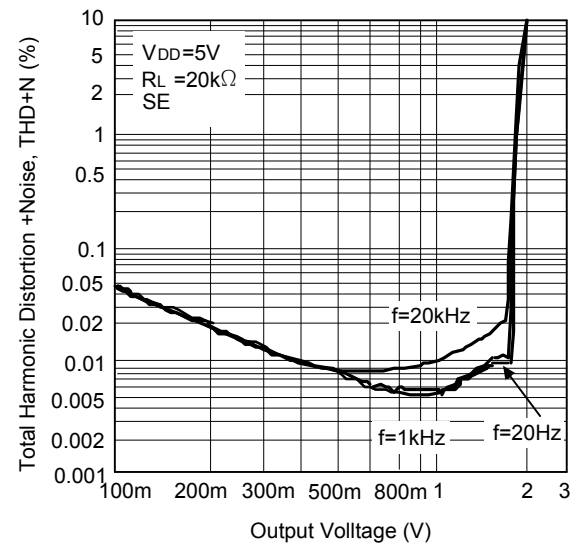
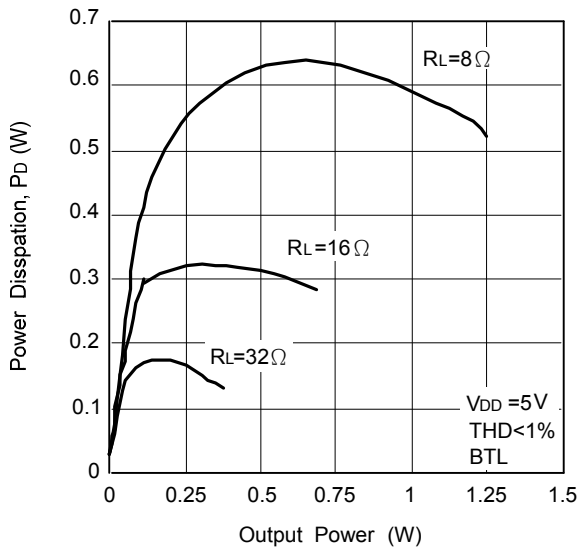
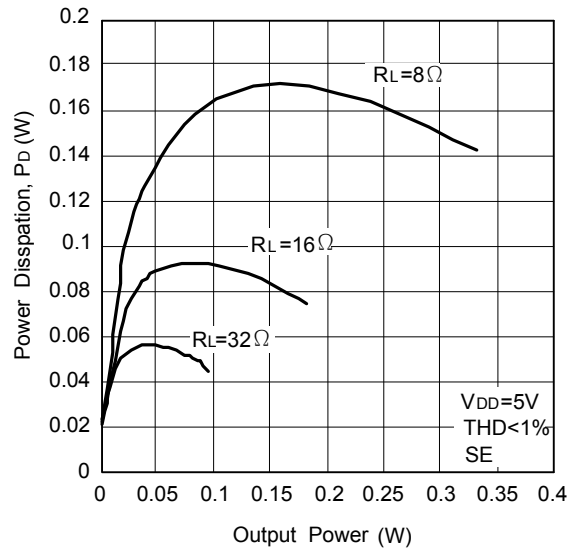
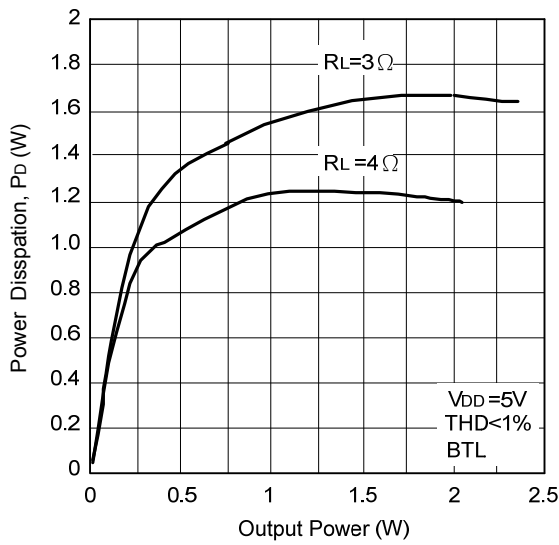

■ TYPICAL CHARACTERISTICS (Cont.)

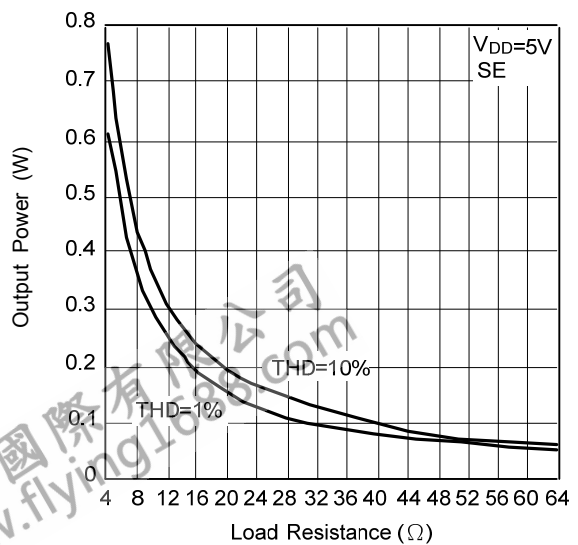
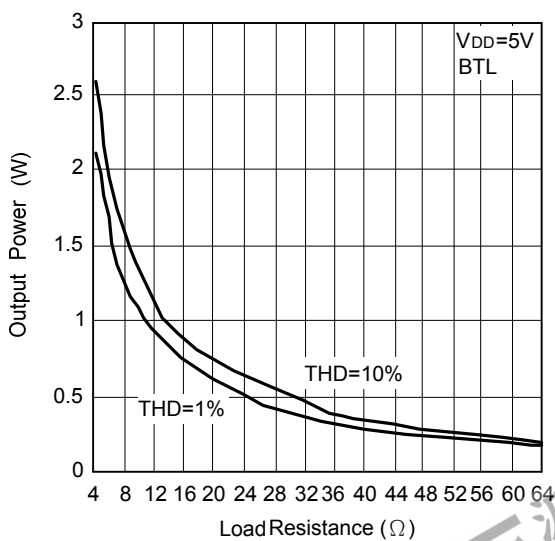
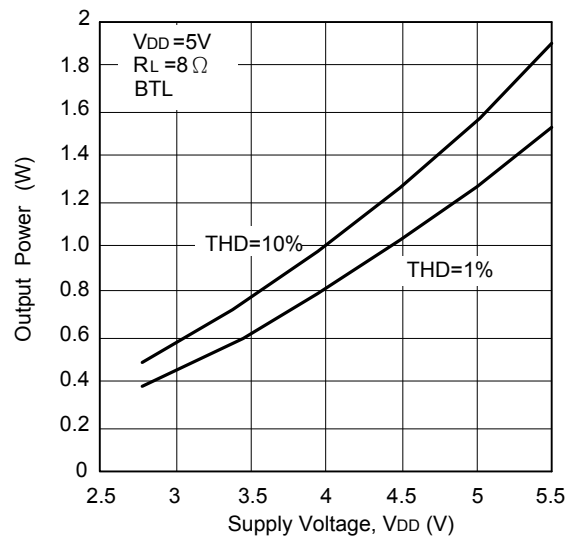
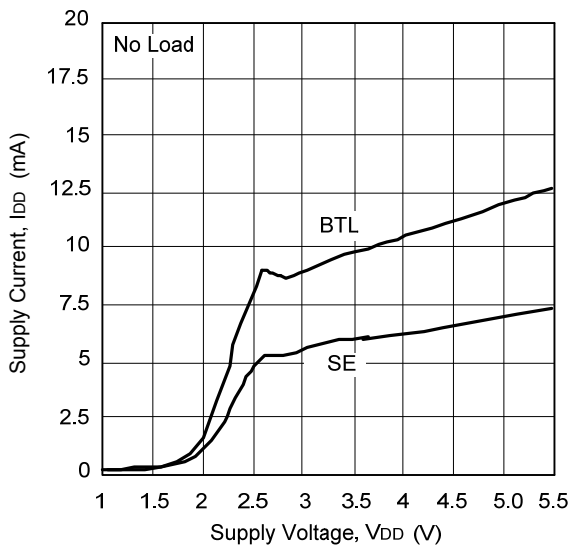
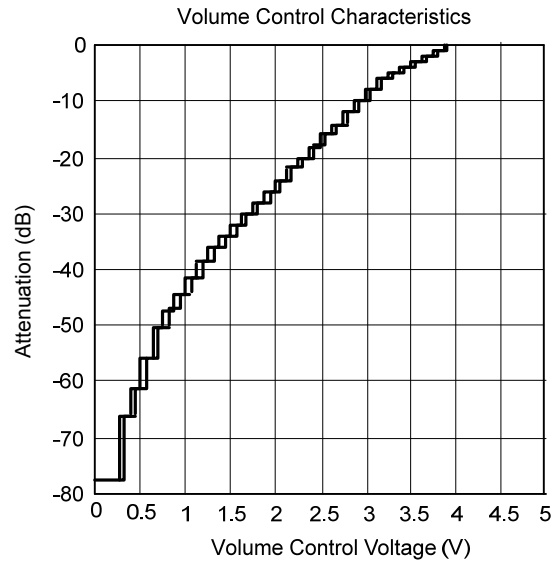
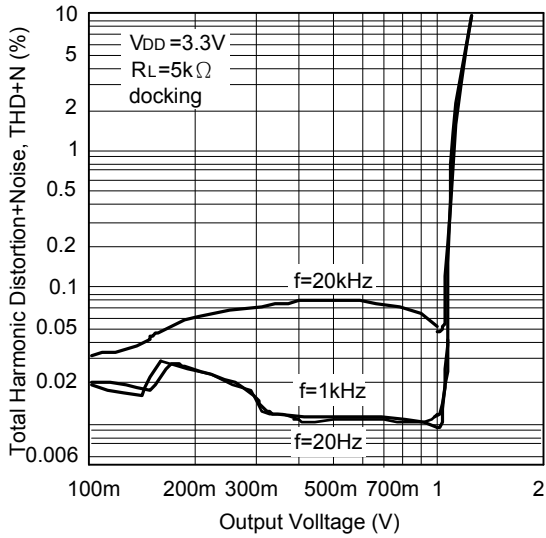

■ TYPICAL CHARACTERISTICS (cont.)

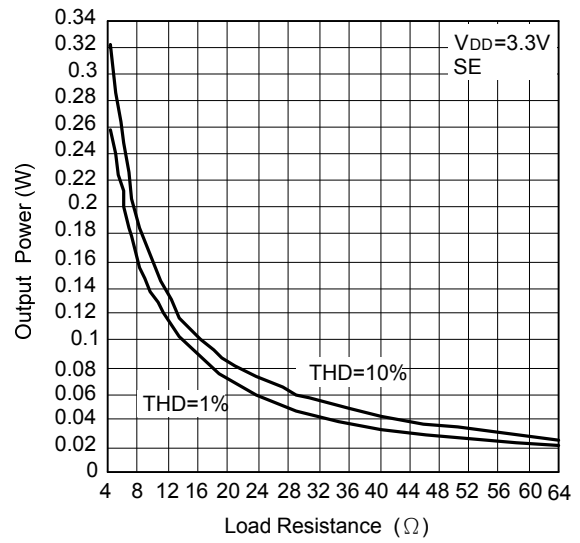
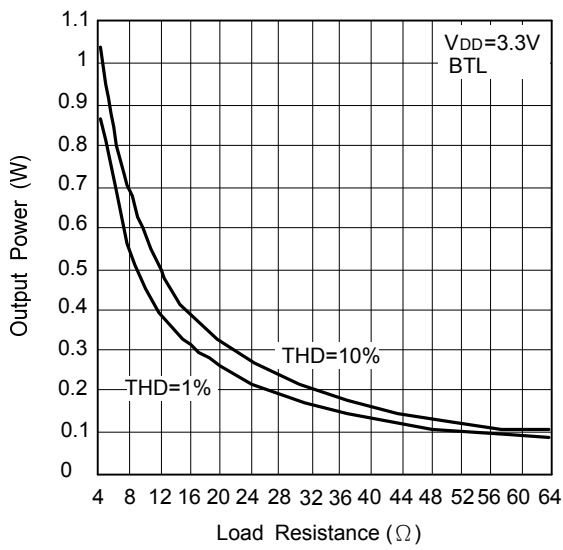

UTC assumes no responsibility for equipment failures that result from using products at values that exceed, even momentarily, rated values (such as maximum ratings, operating condition ranges, or other parameters) listed in products specifications of any and all UTC products described or contained herein. UTC products are not designed for use in life support appliances, devices or systems where malfunction of these products can be reasonably expected to result in personal injury. Reproduction in whole or in part is prohibited without the prior written consent of the copyright owner. The information presented in this document does not form part of any quotation or contract, is believed to be accurate and reliable and may be changed without notice.