



RBA8206

Preliminary

LINEAR INTEGRATED CIRCUIT

REMOTE FAN CONTROL IC

DESCRIPTION

The UTC **RBA8206** is an electronic fan controller LSI utilizing CMOS technology. Both key control input and remote control input are provided to build the highest performance with the least external components. Besides speed mode control, swing control, off-timer and light control, this device offers wind mode control and buzzer output. All of these characteristics above make UTC **RBA8206** can be used to build a full function electronic fan with remote control capability.

FEATURES

- * Low power consumption
- * Three speed modes: Strong, Middle and Low
- * Three operation modes: Ordinary, Nature and Rhythm Sleep
- * Work mode memory
- * Middle wind start-up
- * Buzzer indicator function operation
- * 2-bits consumer code
- * Uses 455kHz crystal oscillator

ORDERING INFORMATION

Ordering Number		Package	Packing
Lead Free	Halogen Free		
RBA8206L-xx-D20-T	RBA8206G-xx-D20-T	DIP-20	Tube

<p>RBA8206L-xx-D20-T</p> <p>(1) Packing Type (2) Package Type (3) Time Output (4) Halogen Free</p>	<p>(1) T: Tube (2) D20: DIP-20 (3) refer to TIME OUTPUT AND MODE (4) L: Lead Free, G: Halogen Free</p>
--	--

TIME OUTPUT AND MODE

PART NUMBER	ACCUMULATED	NON-ACCUMULATED	INDEPENDENT ON/OFF	LIGHT CONTROL
A4	⊙	-	-	⊙

Note: A4 indicated have four time output (0.5, 1, 2, 4 hour) accumulated timer mode.

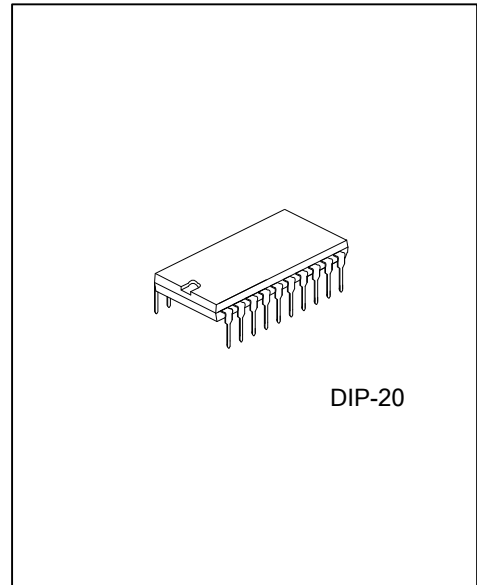

PIN CONFIGURATION

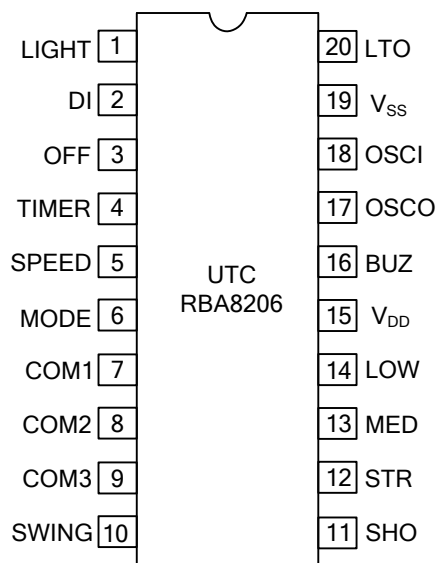

■ PIN DESCRIPTION

PIN NO.	PIN NAME	DESCRIPTION
1	LIGHT	Light control key input
2	DI	Remote control sensor input
3	OFF	OFF control key input, shared with LED scan output
4	TIMER	TIMER control key input and LED scan output
5	SPEED	SPEED key control input and LED scan output
6	MODE	MODE key control input and LED scan output
7	COM1	Consumer code C2 and LED scan common port
8	COM2	Consumer code C1 and LED scan common port
9	COM3	LED scan common port
10	SWING	SWING key control input
11	SHO	Swing drive output, level swing
12	STRONG	Strong wind drive output
13	MEDIUM	Middle wind drive output
14	LOW	Low wind drive output
15	V _{DD}	Positive power
16	BUZ	Buzzer drive output
17	OSCO	455kHz oscillator input/output port
18	OSCI	455kHz oscillator input/output port
19	V _{SS}	Negative power
20	LTO	Light drive output

■ BLOCK DIAGRAM

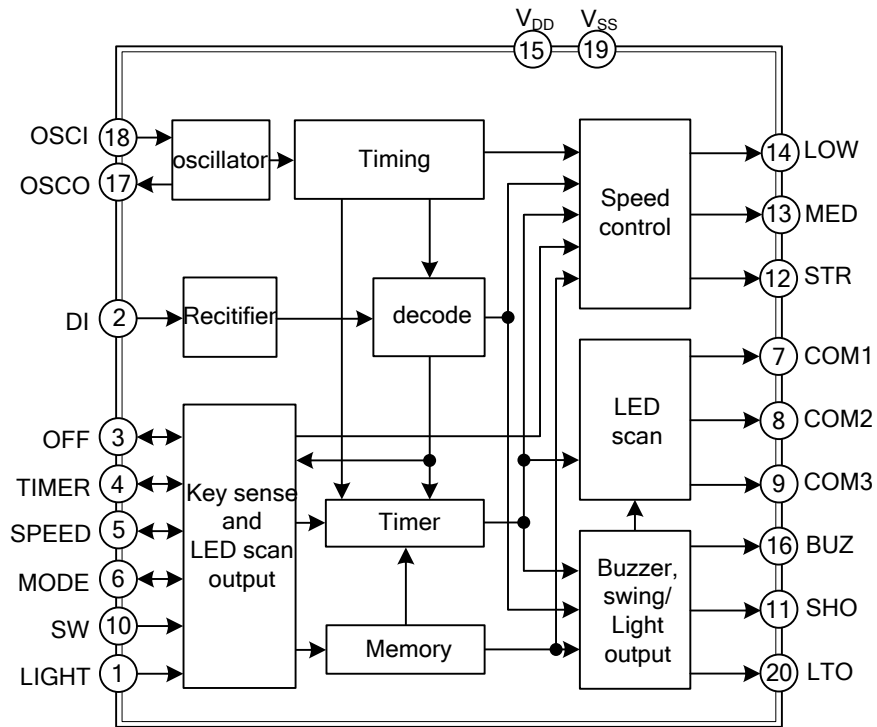

■ ABSOLUTE MAXIMUM RATING (T_A=25°C)

PARAMETER	SYMBOL	RATINGS	UNIT
Supply Voltage	V _{DD}	-0.3~6	V
Input/Output Voltage	V _{IN}	V _{SS} -0.3~V _{DD} +0.3	V
Power Consumption	P _D	500	mW
Operating Temperature	T _{OPR}	-10~+70	°C
Storage Temperature	T _{STG}	-40~+125	°C

Note: Absolute maximum ratings are those values beyond which the device could be permanently damaged. Absolute maximum ratings are stress ratings only and functional device operation is not implied.

■ DC ELECTRICAL CHARACTERISTICS (T_A=25°C, V_{DD}=5.0V, unless special)

PARAMETER	SYMBOL	TEST CONDITIONS	MIN	TYP	MAX	UNIT
Supply Voltage	V _{DD}		3.0	5.0	6.0	V
Static Consumption Current	I _{SB}	V _{DD} =5V, OSC Stop, no Load		1.35		mA
Input High Level Voltage	V _{IH}		0.7×V _{DD}		V _{DD}	V
Input Low Level Voltage	V _{IL}		0		0.3×V _{DD}	V
OFF, MODE, SPEED, TIMER Scan Output Current	I _{OH}	V _{DD} =5.0V, V _O =3.5V		10		mA
COM1~COM3 Scan Output Sink Current	I _{OL}	V _{DD} =5.0V, V _O =0.7V		-40		mA
Drive Output Current	I _{OL}	V _{DD} =5.0V, V _O =0.7V		-10		mA
Buzzer Output Current	I _{OH}	V _{DD} =5.0V, V _O =3.5V		5		mA
Oscillated Frequency	F _{OSC}			455		kHz

■ FUNCTION DESCRIPTION

The UTC **RBA8206** is an electronic fan control IC, it use electronic touch switch and timer replace the traditional switch and timer. UTC **RBA8206** improved nature wind and sleep wind mode expect hold the traditional fan functions, and improved a swing control and light control function. UTC **RBA8206** cooperate with the UTC **RBA5104** encode IC, implement the remote control of the fan.

“OFF” key:

It used to shut down the power of motor, fan stop operating, and the control circuit resume static state, and stored he operate mode of power on. When started next time, it is activated into the operation mode stored in the operation memory. (Timer and sleep wind mode will not be stored)

“ON/SPEED” key:

It start fan if pressed when fan is off. It turn on the fan with middle wind for increase start moment. After three second, it resume low wind mode, or the operation mode stored in the operating memory.

This key set the operate mode when fan is on, if successive pressing of ON/SPEED key, it will operate as low wind, middle wind, strong wind, low wind, middle windgo along with cycle.

“MODE” key:

It used to select the operating mode. If pressed successively when fan is on, it will operate as follows: normally wind, nature wind, sleep wind, normally, nature wind ...go along with cycle.

A) Ordinary wind: the he wind speed is set by SPEED key and does not change as time passes.

B) Nature wind: it is set in program, and operate with “SPEED” key, can produce strong nature wind, middle nature wind, low nature wind, simulate the really nature wind.

C) Sleep wind: In sleep wind mode, the wind speed steps down automatically one level every interval, until it reaches low wind level.

Where is the rule of down:

1) If fan set in strong wind mode at first, it operate in strong nature wind for half an hour, then switch into middle nature wind, after half an hour switch into low nature wind, until the preset time end or turn off fan.

2) If fan set in middle wind mode at first, it operates in middle nature wind for half an hour, then switch into low nature wind, until the preset time end or turn off fan.

3) If fan set in low nature wind at first, it operates in low nature wind, until the preset time end or turn off.

“TIMER” key:

This key used to set the preset off time.

Type mark with “A4” mean have four section time output (0.5, 1, 2, 4hour) accumulated.

When fan is in the time mode, LED will indicate the remain time, means the fan will stop after the display time.

“SWING” key:

If pressed when fan is in the operate mode, it can control the fan swing, it is invalid when fan stooped.

“LIGHT” key:

It is used to control light, is independent of the operate mode.

Buzzer output:

1) Turn on send out “Bi-Bi”

2) Turn off send out “Bi-”

3) Other available operate (include key press and remote controller receive) send out “Bi”

■ CONTROL PANEL

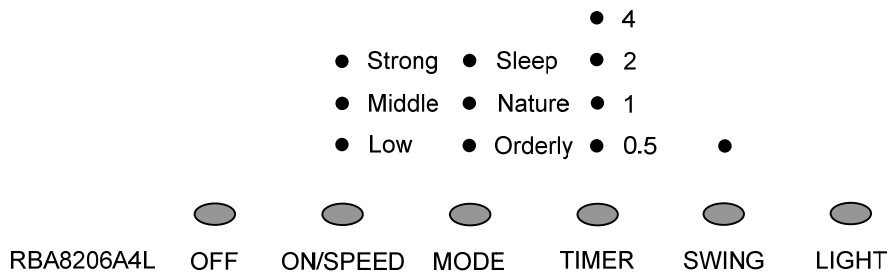

■ TYPICAL APPLICATION CIRCUIT

Transmitter controller unit

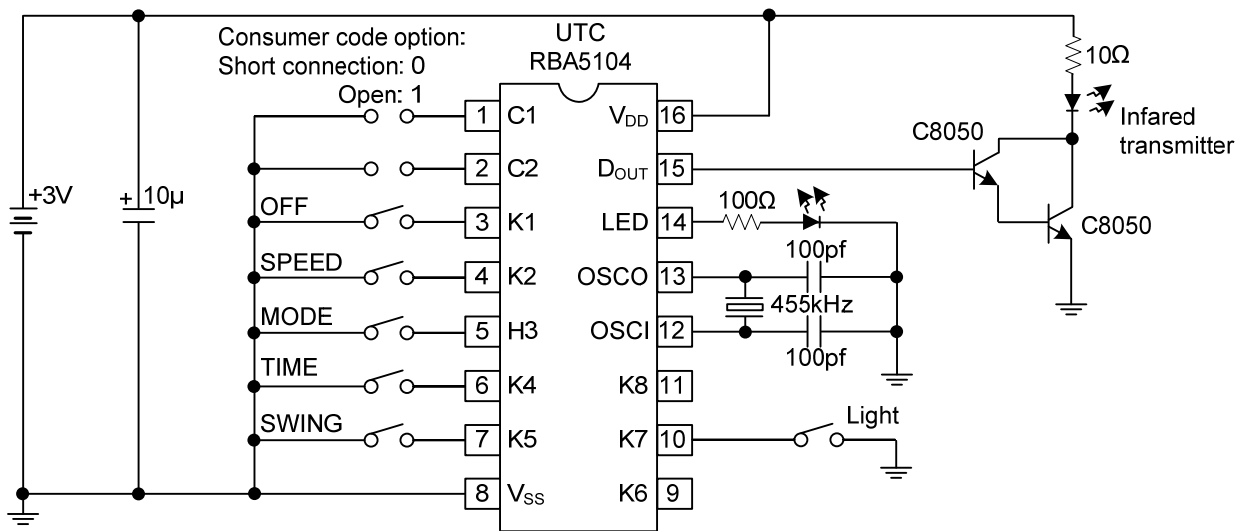

TYPICAL APPLICATION CIRCUIT

receive control unit

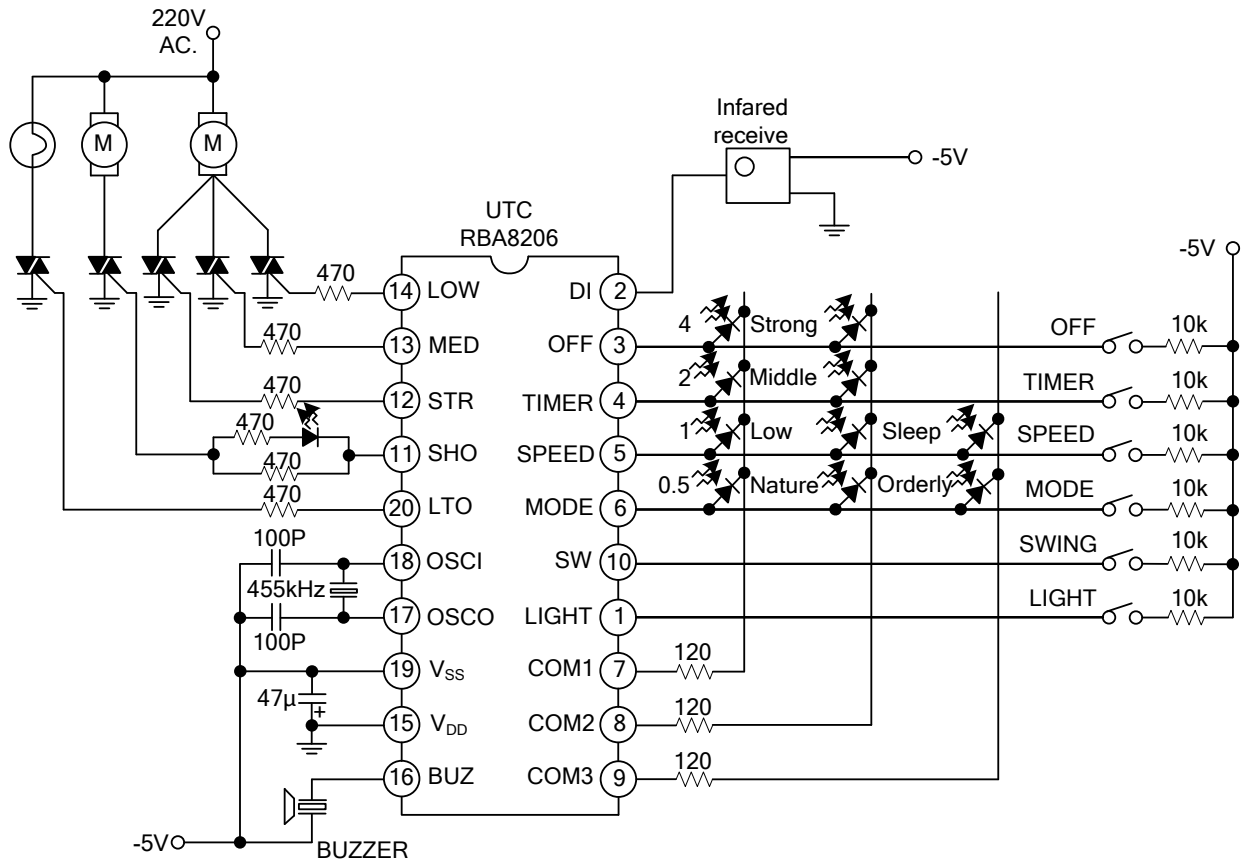

Power circuit

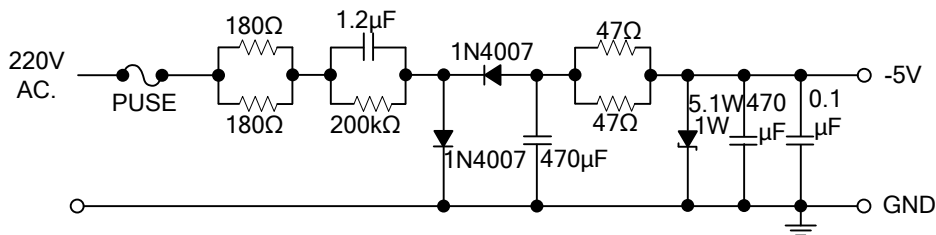

UTC assumes no responsibility for equipment failures that result from using products at values that exceed, even momentarily, rated values (such as maximum ratings, operating condition ranges, or other parameters) listed in products specifications of any and all UTC products described or contained herein. UTC products are not designed for use in life support appliances, devices or systems where malfunction of these products can be reasonably expected to result in personal injury. Reproduction in whole or in part is prohibited without the prior written consent of the copyright owner. The information presented in this document does not form part of any quotation or contract, is believed to be accurate and reliable and may be changed without notice.