



RCR02

CMOS IC

DECODER FOR REMOTE CONTROLLER WITH FIVE FUNCTIONS

DESCRIPTION

The chip can be used with the encoder RCT02 to provide a complete control functions to the remote-controlled toy. The **RCR02** has five output pins corresponding with the five function actions i.e, forward, backward, rightward, leftward and turbo. The received signals are amplified by the three-stage amplifier, and then the appropriate amplified signals are sampled, fault-tolerantly checked and decoded to control the actions of the remote-controlled toy.

There is an internal oscillator in the **RCR02**. By adding an external resistor conveniently, the oscillator will be constructed. The oscillator frequency can be adjusted by the external resistor. The relative error between the frequencies of the two on chip oscillators in the RCT02 and **RCR02** must be less than $\pm 25\%$.

FEATURES

- * Five output pins for control functions
- * Operating power-supply voltage range: 2.5 to 5.0V
- * On-chip reversing amplifiers
- * On-chip oscillator with an external resistor
- * Low operating current
- * Few external components needed

ORDERING INFORMATION

Ordering Number		Package	Packing
Lead Free	Halogen Free		
RCR02L-D16-T	RCR02G-D16-T	DIP-16	Tube
RCR02L-S16-R	RCR02G-S16-R	SOP-16	Tape Reel

<p>RCR02G-D16-T</p> <p>(1) Packing Type (2) Package Type (3) Green Package</p>	<p>(1) T: Tube, R: Tape Reel (2) D16: DIP-16, S16: SOP-16 (3) G: Halogen Free and Lead Free, L: Lead Free</p>
--	---

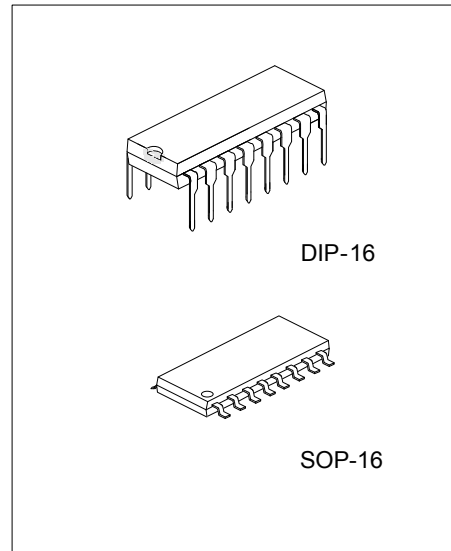

MARKING

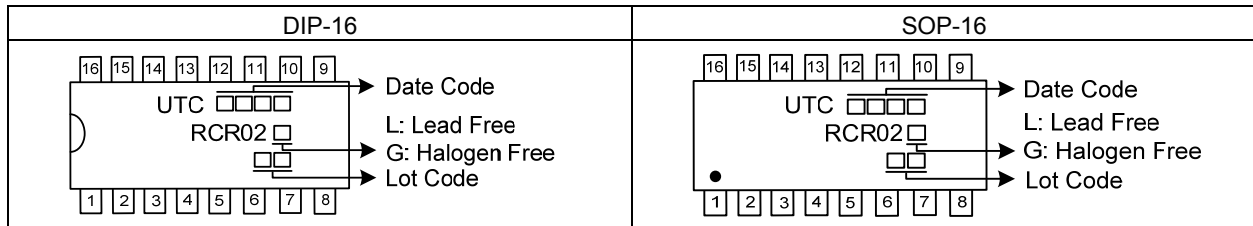

PIN CONFIGURATION

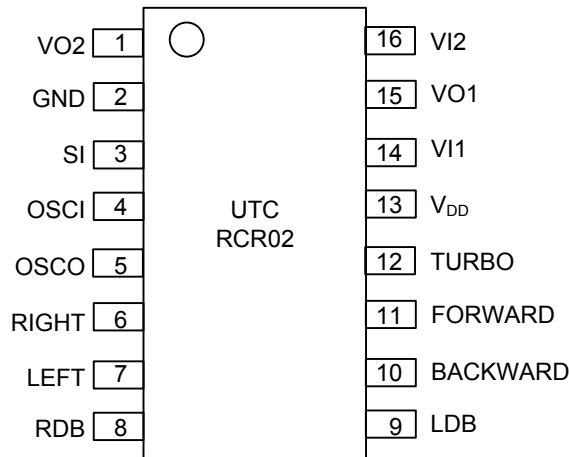

PIN DESCRIPTION

PIN NO.	PIN NAME	FUNCTION
1	VO2	Output pin for the amplifier 2
2	GND	Negative power supply
3	SI	Input pin of the encoding signal
4	OSCI	Oscillator input pin
5	OSCO	Oscillator output pin
6	RIGHT	Rightward output pin
7	LEFT	Leftward output pin
8	RDB	Rightward function disable, if this pin is connected to GND
9	LDB	Leftward function disable, if this pin is connected to GND
10	BACKWARD	Backward output pin
11	FORWARD	Forward output pin
12	TURBO	Turbo output pin
13	V _{DD}	Positive power supply
14	VI1	Input pin for the amplifier 1
15	VO1	Output pin for the amplifier 1
16	VI2	Input pin for the amplifier 2

■ BLOCK DIAGRAM

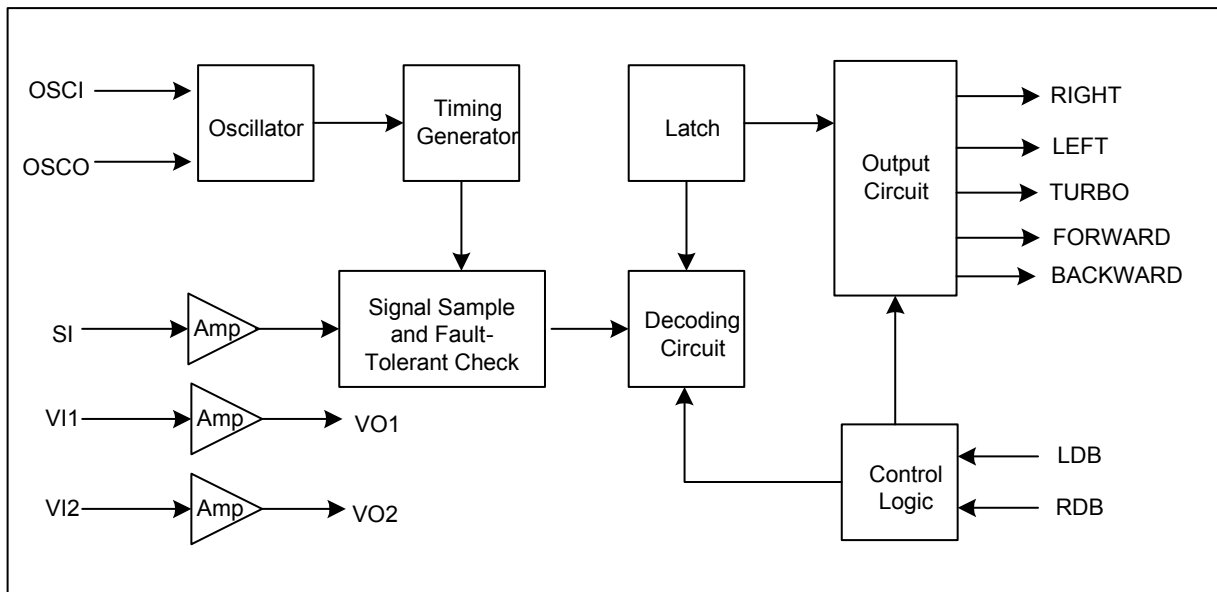

■ ABSOLUTE MAXIMUM RATING

PARAMETER	SYMBOL	RATINGS	UNIT
DC Input Voltage	V_{IN}	+5.5	V
Supply Voltage to Ground Potential (Inputs & V_{DD} Only)		+5.5	V
Supply Voltage to Ground Potential (Outputs & D/O Only)		+5.5	V
DC Output Current	I_o	20	mA
Power Dissipation	P_D	500	mW
Ambient Temperature With Power Applied	T_A	-10 ~ +40	°C
Storage Temperature	T_{STG}	-25 ~ +85	°C

Note: Absolute maximum ratings are those values beyond which the device could be permanently damaged. Absolute maximum ratings are stress ratings only and functional device operation is not implied.

■ DC ELECTRICAL CHARACTERISTICS

(Over the operating rating, $T_A = -10^{\circ}\text{C} \sim +40^{\circ}\text{C}$, $V_{DD} = 4.0\text{V} \pm 10\%$)

PARAMETER	SYMBOL	TEST CONDITIONS	MIN	TYP	MAX	UNIT
Operating Voltage	V_{DD}		2.5	4.0	5.0	V
Supply Current	I_{DD}	(Note)			3.0	mA
Input Current	I_{IN}	For RDB and LDB pins			60	μA
Input Low Voltage	V_{IL}	For RDB and LDB pins			0.5	V
Input High Voltage	V_{IH}	For RDB and LDB pins	3.5			V
Output High Voltage	V_{OH}	$I_{OUT} = 400\mu\text{A}$	3.5			V
Output High Current	I_{OH}	$V_{OUT} = 1.4\text{V}$	-1.5			mA
Output Low Voltage	V_{OL}	$I_{OUT} = 1.0\text{mA}$			0.5	V
Output Low Current	I_{OL}	$V_{OUT} = 0.5\text{V}$	1.0			mA

Note: Output unloaded; 2.2M Ω feedback resistors for the two reversing amplifiers; 200K Ω external resistor for the on-chip oscillator.

■ AC ELECTRICAL CHARACTERISTICS

PARAMETER	SYMBOL	TEST CONDITIONS	MIN	TYP	MAX	UNIT
Oscillator Frequency*	F_{OSC}	$T_A = 25^{\circ}\text{C}$, $R = 200\text{K}\Omega$	102	128	154	KHz
SI Pin Vpp Receive Sensitivity	V_{SI}	Guaranteed Effective Decoding	300			mV
Cycle Time of Function Code	T_{FUN}	$F_{OSC} = 128\text{KHz}$	0.75	1	1.25	ms
Cycle Time of Start Code	T_{STA}	$F_{OSC} = 128\text{KHz}$	1.5	2	2.5	ms

Note: The relative error between the frequencies of the two on-chip oscillators in the RCT02 and RCR02 must be less than $\pm 25\%$.

■ BIT FORMAT FOR THE RECEIVED SIGNAL (W1 is used for function codes,W2 for start codes)

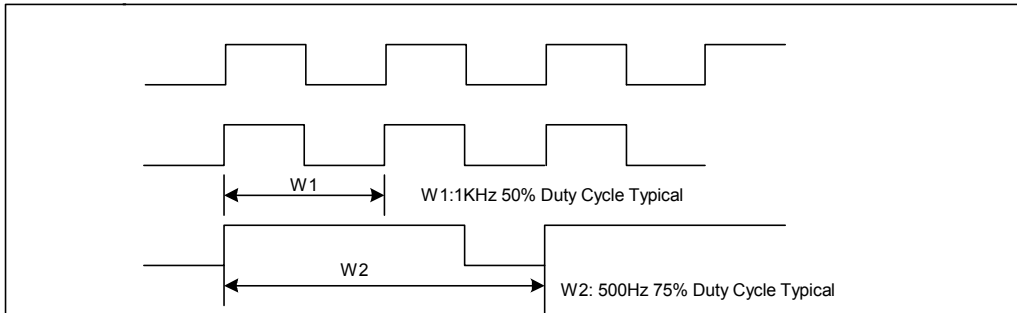

■ WORD FORMAT FOR RECEIVED SIGNAL

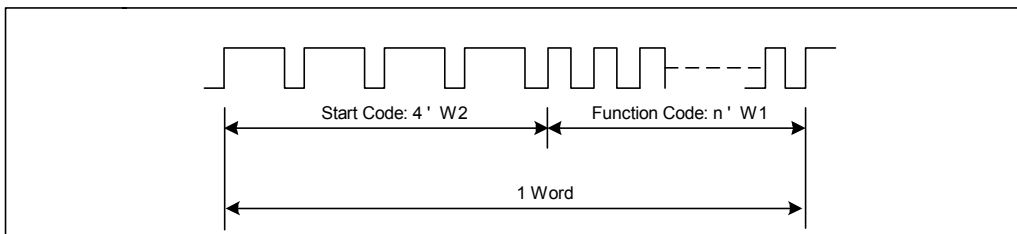

■ ENCODING INPUT FORMAT AND DECODING RESULT

W2 W2 W2 W2 (n)' W1 W2 W2 W2 W2 (n)' W1 W2 W2 W2 W2 (n)' W1 W2 W2 W2 W2 (n)' W1-----

Number of Function Codes(n)W1	Decoding Result
4	End Code
10	Forward
16	Forward
22	Turbo
28	Forward & Left
34	Forward & Right
40	Backward
46	Backward & Right
52	Backward & Left
58	Left
64	Right

■ DECODING TIMING

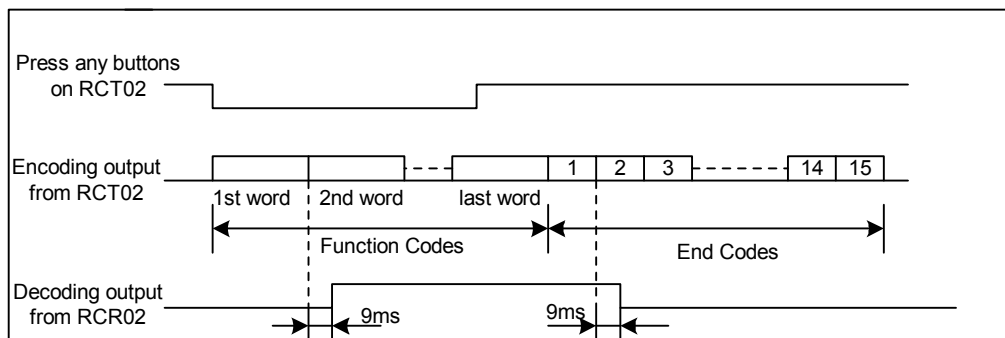

■ BLOCK DIAGRAM OF APPLICATION CIRCUIT

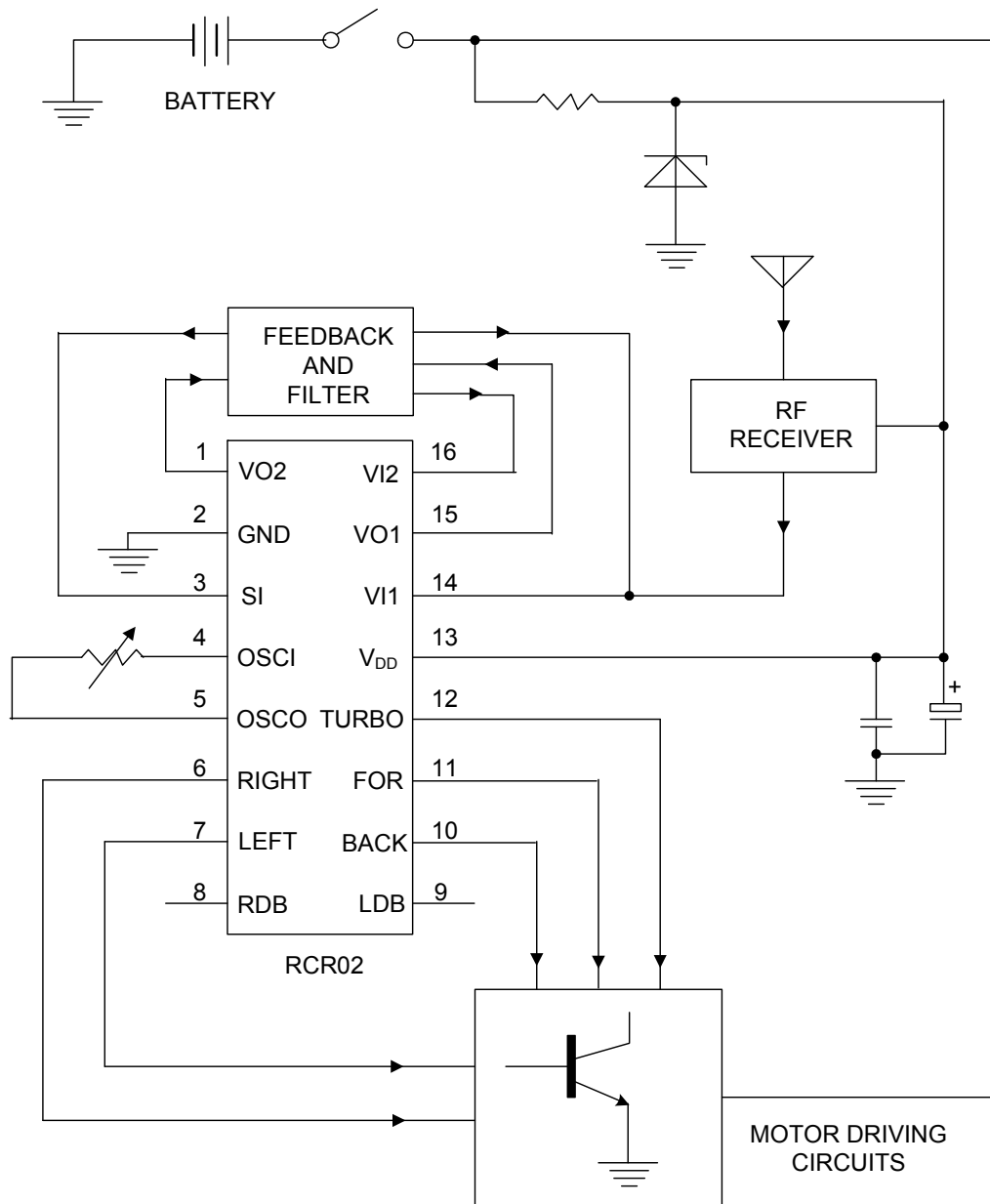

■ TYPICAL APPLICATION FOR RECEIVE CIRCUIT WITH FIVE FUNCTION

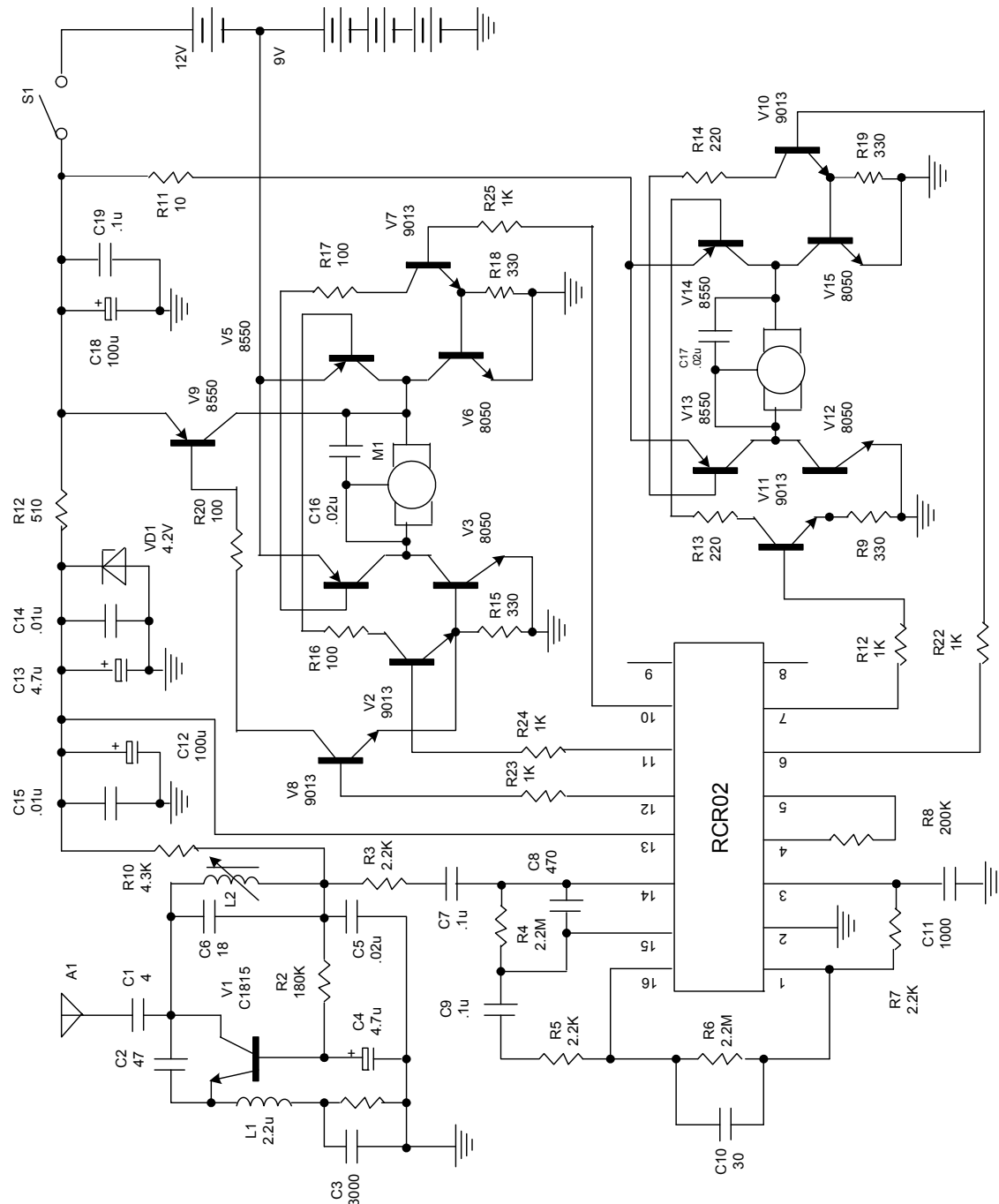

UTC assumes no responsibility for equipment failures that result from using products at values that exceed, even momentarily, rated values (such as maximum ratings, operating condition ranges, or other parameters) listed in products specifications of any and all UTC products described or contained herein. UTC products are not designed for use in life support appliances, devices or systems where malfunction of these products can be reasonably expected to result in personal injury. Reproduction in whole or in part is prohibited without the prior written consent of the copyright owner. UTC reserves the right to make changes to information published in this document, including without limitation specifications and product descriptions, at any time and without notice. This document supersedes and replaces all information supplied prior to the publication hereof.