



## RCR2C

CMOS IC

### DECODER FOR REMOTE CONTROLLER WITH FIVE FUNCTIONS

#### DESCRIPTION

The UTC **RCR2C** can be used with the encoder UTC RCT2E to provide a complete control functions to the remote-controlled toy. The UTC **RCR2C** is the receiver. It is provide five function keys to control forward, Backward, Rightward, Leftward and Turbo motions. Beside, a combination of these five motions can be played. And UTC **RCR2C** provides the selections of Output Signal Format.

UTC **RCR2C** provides two high effective amplifiers and enhance Signal Input (SI) recognition capacity for increasing remote control distance.

UTC **RCR2C** has an internal, selectable DC-DC converter that makes the application stable, reliable under lower supply voltage. The input voltage ranges from 0.8v ~ 3.0V, where  $V_{OUT}$  can be set to 3.0V. Start-up is guaranteed from 1.0V inputs.

#### FEATURES

\* Wide and Low operating voltage range:

1.8V ~ 5.0V(No DC-DC)

1.0V ~ 5.0V(Use DC-DC)

\* 5-function output pins for control forward/ backward/ turbo/ right/ left.

\* Provide two transmissive interface (RF and IR) for different application.

\* Selectable Output Signal Format through MOD pin

\* Internal, Selectable DC-DC converter which need few external components

\* Provide two high effective amplifiers and enhance signal input (SI) recognition capacity for very weak signal for increasing remote control distance.

\* Few external components needed and Oscillator with an external resistor.

\* Low operating current.

\* Long distance Remote Control to 100M in UTC RCT2E and UTC **RCR2C** pairing.

\* Typical oscillator frequency:

RF: 116~140KHz.

IR: 114KHz(Carrier Frequency: 57KHz).

IR: 76KHz(Carrier Frequency: 38KHz).

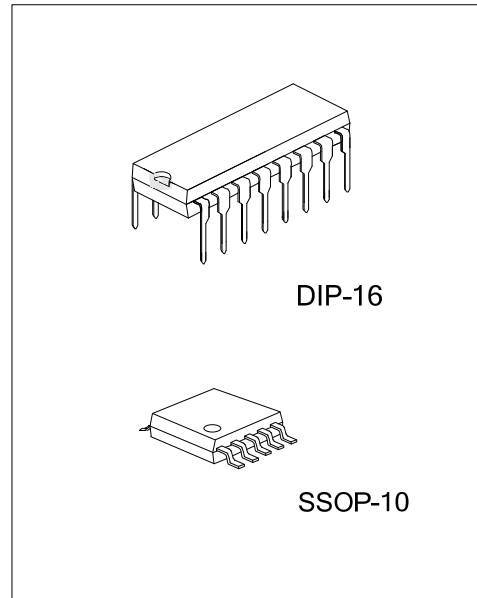

#### ORDERING INFORMATION

Order Number		Package	Packing
Lead Free	Halogen Free		
RCR2CL-D16-T	RCR2CG-D16-T	DIP-16	Tube
-	F1962G-R10-R	SSOP-10	Tape Reel

<p>RCR2CL-D16-T</p> <ul style="list-style-type: none"> <li>(1)Packing Type</li> <li>(2)Package Type</li> <li>(3)Green Package</li> </ul>	<ul style="list-style-type: none"> <li>(1) T: Tube, R: Tape Reel</li> <li>(2) D16: DIP-16, R10: SSOP-10</li> <li>(3) L: Lead Free, G: Halogen Free and Lead Free</li> </ul>
--	---

## MARKING

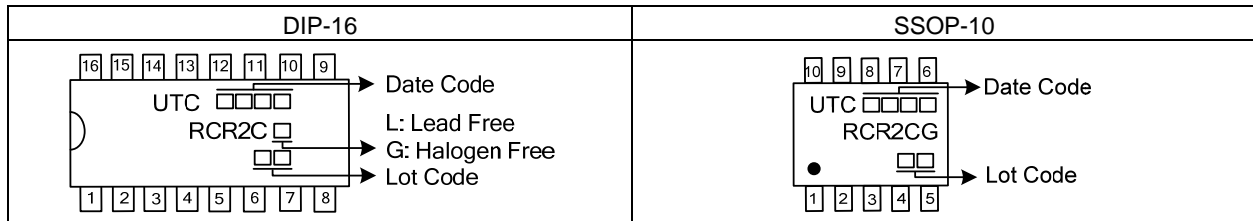

## PIN CONFIGURATION

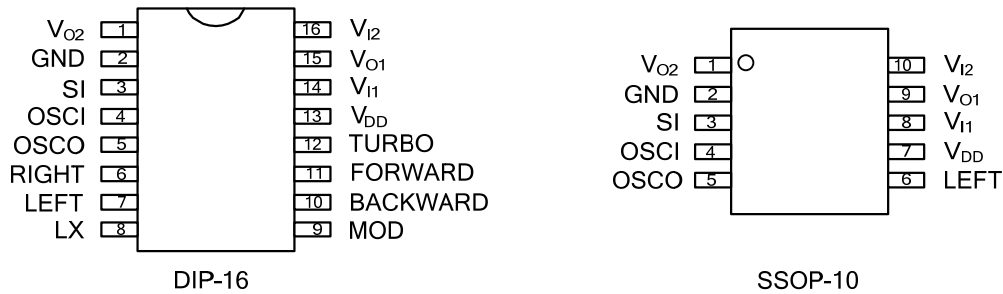

## PIN DESCRIPTION

PIN NO.	PIN NAME	FUNCTION
1	V <sub>O2</sub>	Inverter 2 output pin for power amplify
2	GND	Negative power supply
3	SI	Input pin of the encoding signal
4	OSCI	Oscillator input pin
5	OSCO	Oscillator output pin
6	RIGHT	Rightward output pin
7	LEFT	Leftward output pin
8	LX	DC-DC converter output pin
9	MOD	Output-signal-format selection input pin. High=Open. When Mod is open, the output Signal is same format as UTC RCR2C. When it is pulled low, there is the other Format.
10	BACKWARD	Backward output pin
11	FORWARD	Forward output pin
12	TURBO	Turbo output pin
13	V <sub>DD</sub>	Positive power supply
14	V <sub>I1</sub>	Inverter 1 input pin for power amplify
15	V <sub>O1</sub>	Inverter 1 output pin for power amplify
16	V <sub>I2</sub>	Inverter 2 input pin for power amplify

■ BLOCK DIAGRAM

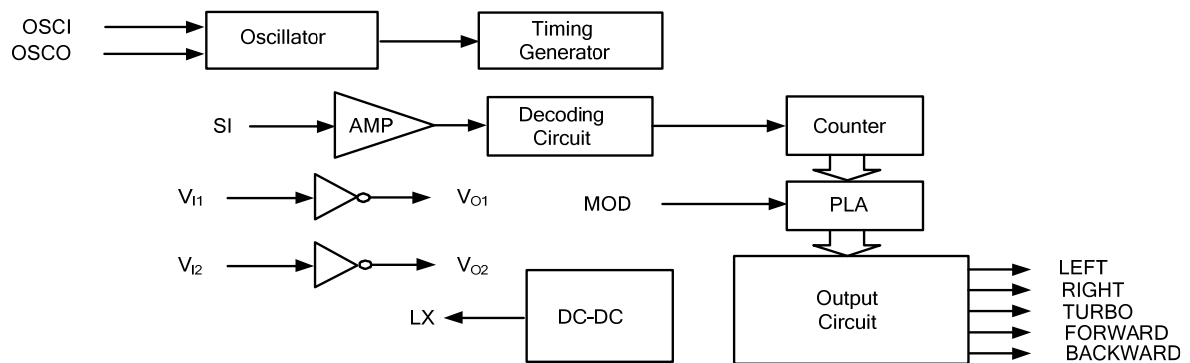

■ ABSOLUTE MAXIMUM RATING

PARAMETER	SYMBOL	RATINGS	UNIT
DC Supply Voltage	V <sub>DD</sub>	-0.3 ~ 6.0	V
Input/Output Voltage		GND -0.2 ~ V <sub>DD</sub> +0.2	V
Junction Temperature	T <sub>J</sub>	125	°C
Operating Temperature	T <sub>OPR</sub>	-20 ~ +85	°C
Storage Temperature	T <sub>STG</sub>	-40 ~ +150	°C

Note: Absolute maximum ratings are those values beyond which the device could be permanently damaged. Absolute maximum ratings are stress ratings only and functional device operation is not implied.

■ ELECTRICAL CHARACTERISTICS

(V<sub>DD</sub> = 4.5V, F<sub>OSC</sub> = 116 ~ 140KHz, T<sub>A</sub>=25°C, NO DC-DC converter, unless otherwise noted.)

PARAMETER	SYMBOL	TEST CONDITIONS	MIN	TYP	MAX	UNIT
Supply Voltage	V <sub>DD</sub>		1.8	4.5	5.0	V
Operating Current	I <sub>DD</sub>	Unload			1.0	mA
Output Driving Current	I <sub>Driving</sub>	Load=0.7V	4.5			mA
Oscillator Frequency Tolerance	F <sub>tolerance</sub>	UTC RCT2E F <sub>OSC</sub> =128KHz	-20		20	%

■ OUTPUT TABLES

FUNCTION KEY (UTC RCT2E)	DECODE RESULT (MOD = 1)	DECODE RESULT (MOD = 0)
	END CODE	END CODE
FORWARD(L)	FORWARD (H)	FORWARD (Z)
FORWARD(L) & TURBO(L)	FORWARD (H)	FORWARD (H) & TURBO (H)
TURBO(L)	TURBO (H)	FORWARD (H) & TURBO (H)
TURBO(L) & FORWARD(L) & LEFT(L)	FORWARD (H) & LEFT (H)	FORWARD (Z) & LEFT (H)
TURBO(L) & FORWARD(L) & RIGHT(L)	FORWARD (H) & RIGHT (H)	FORWARD (Z) & RIGHT (H)
BACKWARD(L)	BACKWARD (H)	BACKWARD (Z)
BACKWARD(L) & RIGHT(L)	BACKWARD (H) & RIGHT (H)	BACKWARD (Z) & RIGHT (H)
BACKWARD(L) & LEFT(L)	BACKWARD (H) & LEFT (H)	BACKWARD (Z) & LEFT (H)
LEFT(L)	LEFT (H)	LEFT (H)
RIGHT(L)	RIGHT (H)	RIGHT (H)

Note: L=LOW, H=HIGH, Z= 60Hz 50% DUTY Pulse.

## ■ TYPICAL APPLICATION CIRCUIT

Receiver I ( $F_{osc} = 128\text{KHz}$ )

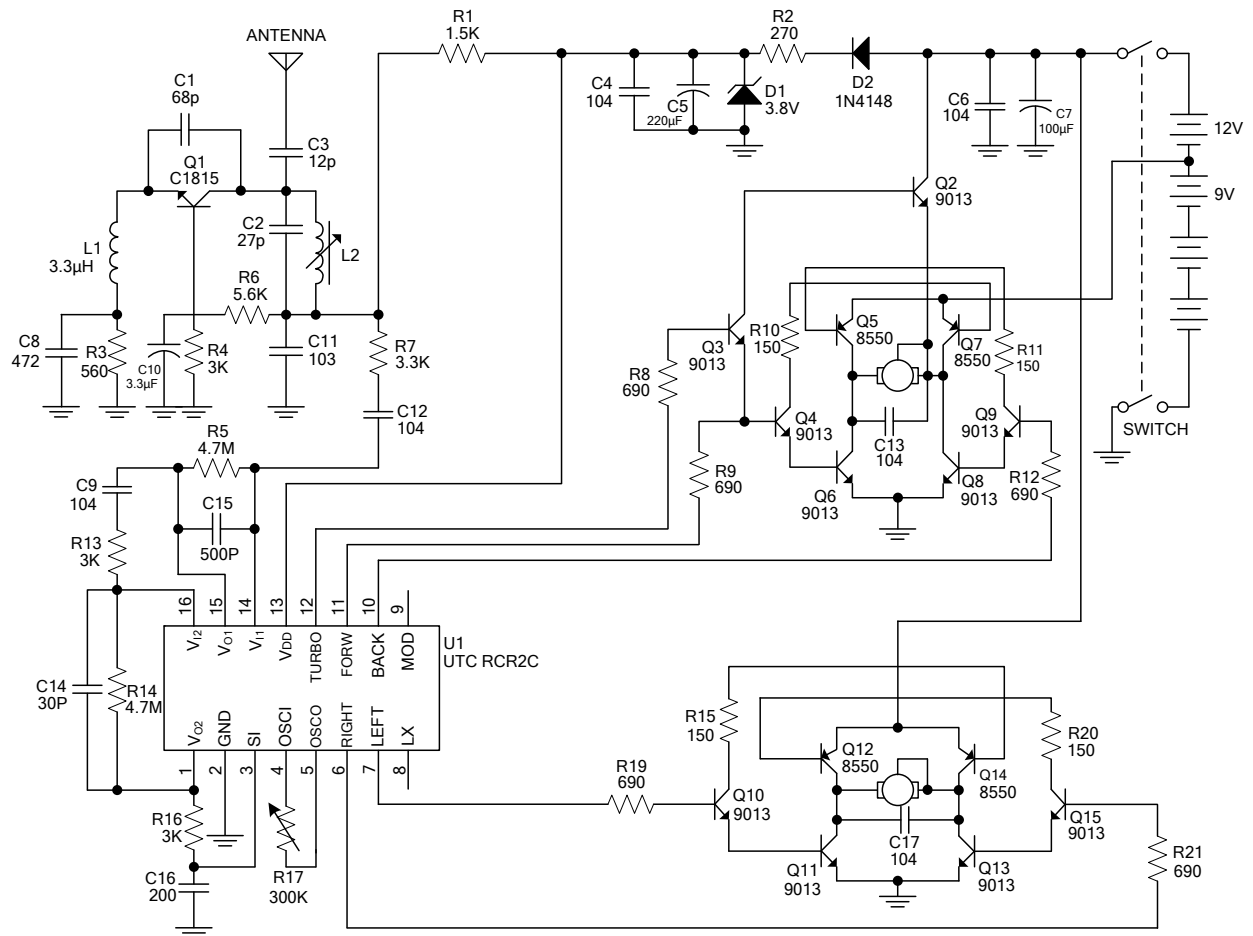

- Notes :
1. MOD=1( Mod Pin opens).
  2. No using DC-DC converter because of higher supply voltage.
  3. Two grade shift gears are realized.

## TYPICAL APPLICATION CIRCUIT

Receiver II ( $F_{OSC} = 116 \sim 140$  KHz)

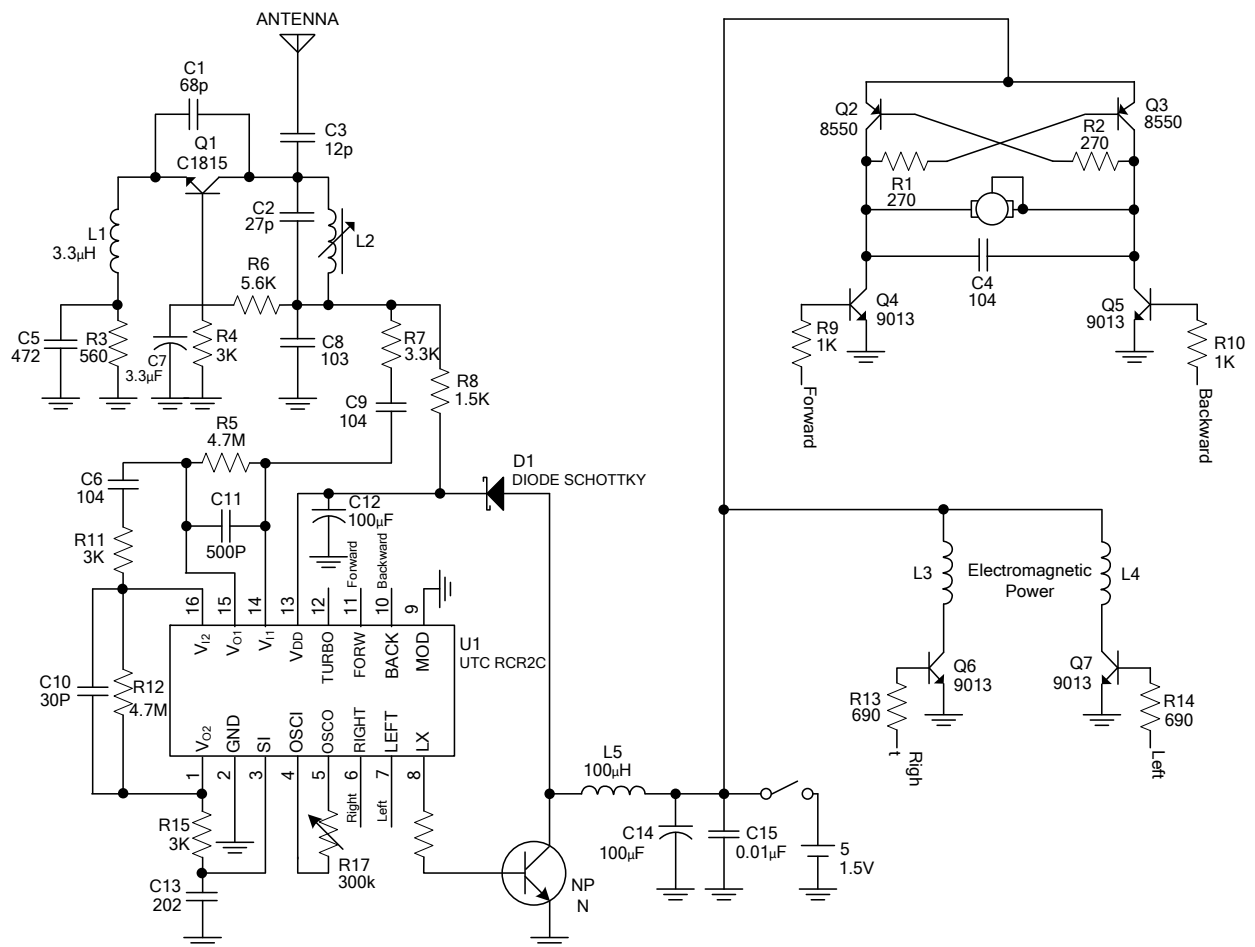

- Notes :
1. MOD=0(pulled low)
  2. Using DC-DC converter because of lower supply voltage
  3. Two grade shift gears are realized

## ■ INFRARED APPLICATION CIRCUIT

Receiver ( $F_{OSC} = 114\text{KHz}$ )

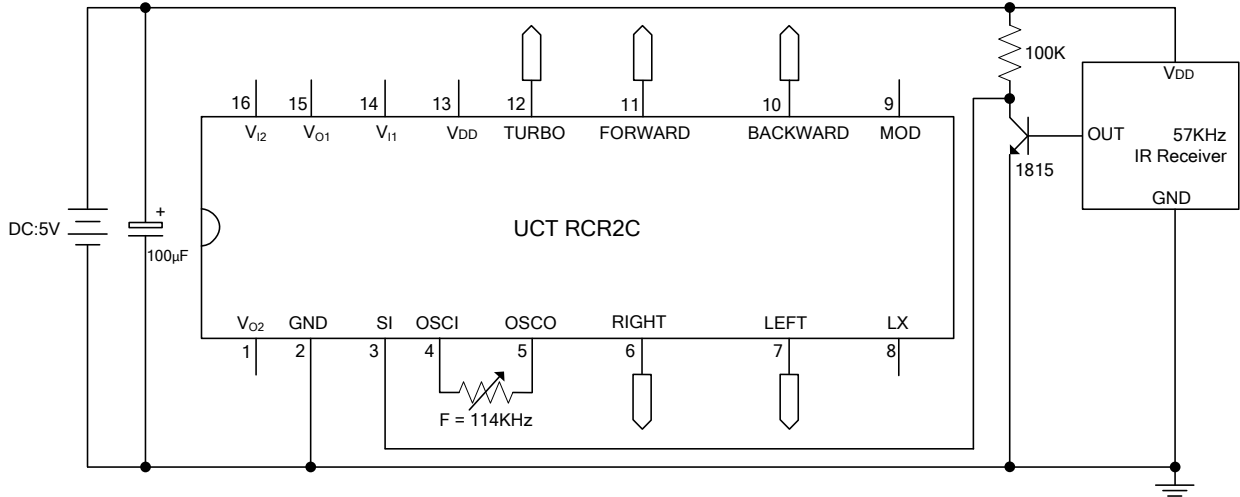

## ■ TESTING CIRCUIT

The oscillator frequency is 116 ~140KHz

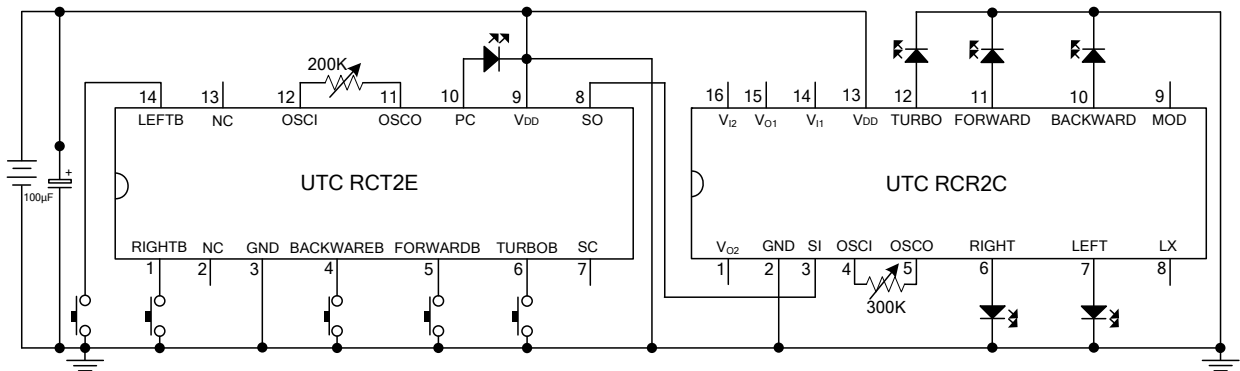

UTC assumes no responsibility for equipment failures that result from using products at values that exceed, even momentarily, rated values (such as maximum ratings, operating condition ranges, or other parameters) listed in products specifications of any and all UTC products described or contained herein. UTC products are not designed for use in life support appliances, devices or systems where malfunction of these products can be reasonably expected to result in personal injury. Reproduction in whole or in part is prohibited without the prior written consent of the copyright owner. The information presented in this document does not form part of any quotation or contract, is believed to be accurate and reliable and may be changed without notice.