



RCT02

CMOS IC

ENCODER FOR REMOTE CONTROLLER WITH FIVE FUNCTIONS

DESCRIPTION

The chip can be used with the decoder UTC **RCR02** to provide a complete control functions to the remote-controlled toy. The UTC **RCT02** has five input pins corresponding with the five function buttons i.e, forward, backward, rightward, leftward and turbo. The encoding circuit in the UTC **RCT02** sends digital codes to the two output pins SO and SC. The digital codes correspond to the definite function buttons or their combinations. The SO and SC outputs are used in wireless and infra-red applications respectively.

There is an internal oscillator in the UTC **RCT02**. By adding an external resistor conveniently, the oscillator will be constructed. The oscillator frequency can be adjusted by the external resistor. The relative error between the frequencies of the two on chip oscillators in the UTC **RCT02** and UTC **RCR02** must be less than $\pm 25\%$.

The auto-power-off function is achieved by an internal counter. When the UTC **RCT02** is powered on, the counter is reset and begin to count. Any action of push down or release the function button also reset the counter. The PC pin will keep on a high level until the counter counts up to about 4 minutes. The PC output is used to control on/off state of the external power supply. Pressing OFF button can also shut down the power supply. Press on any function button will wake up the chip promptly.

FEATURES

- *Five input pins used for five control buttons
- *Operating power-supply voltage range: 2.5 ~ 5.0V
- *Auto-power-off if no press on any button in 4 minutes or continuously press on any button over 4 minutes
- *Manual-power-on/off with ON/OFF button
- *One output pin used for external power control
- *Press on any button as wake up
- *On-chip oscillator with an external resistor
- *Low operating current
- *Few external components needed

ORDERING INFORMATION

Ordering Number		Package	Packing
Lead Free	Halogen Free		
RCT02L-D14-T	RCT02G-D14-T	DIP-14	Tube
RCT02L-S14-T	RCT02G-S14-T	SOP-14	Tube
RCT02L-S14-R	RCT02G-S14-R	SOP-14	Tape Reel

<p>CD4069L-S14-T</p> <p>(1)Packing Type</p> <p>(2)Package Type</p> <p>(3)Lead Free</p>	<p>(1) T: Tube, R: Tape Reel</p> <p>(2) D14: DIP-14, S14: SOP-14</p> <p>(3) L: Lead Free, G: Halogen Free</p>
--	---

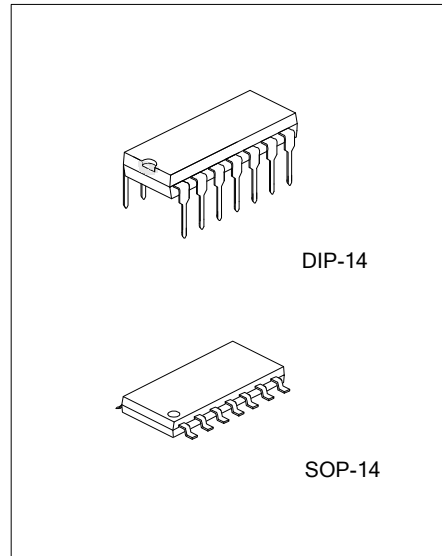

■ PIN CONFIGURATION

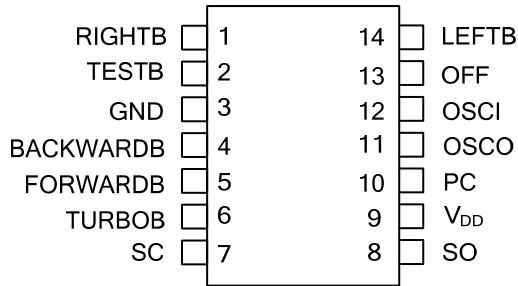

■ PIN DESCRIPTION

Pin No.	Pin Name	Description
1	RIGHTB	The rightward function will be selected, if this pin is connected to GND
2	TESTB	This pin is used for testing mode
3	GND	Negative power supply
4	BACKWARDB	The backward function will be selected, if this pin is connected to GND
5	FORWARDB	The forward function will be selected, if this pin is connected to GND
6	TURBOB	The turbo function will be selected, if this pin is connected to GND
7	SC	Output pin of the encoding signal with carrier frequency
8	SO	Output pin of the encoding signal without carrier frequency
9	V _{DD}	Positive power supply
10	PC	Power control output pin
11	OSCO	Oscillator output pin
12	OSCI	Oscillator input pin
13	OFF	This pin is used to shut down the external power supply
14	LEFTB	The leftward function will be selected, if this pin is connected to GND

■ BLOCK DIAGRAM

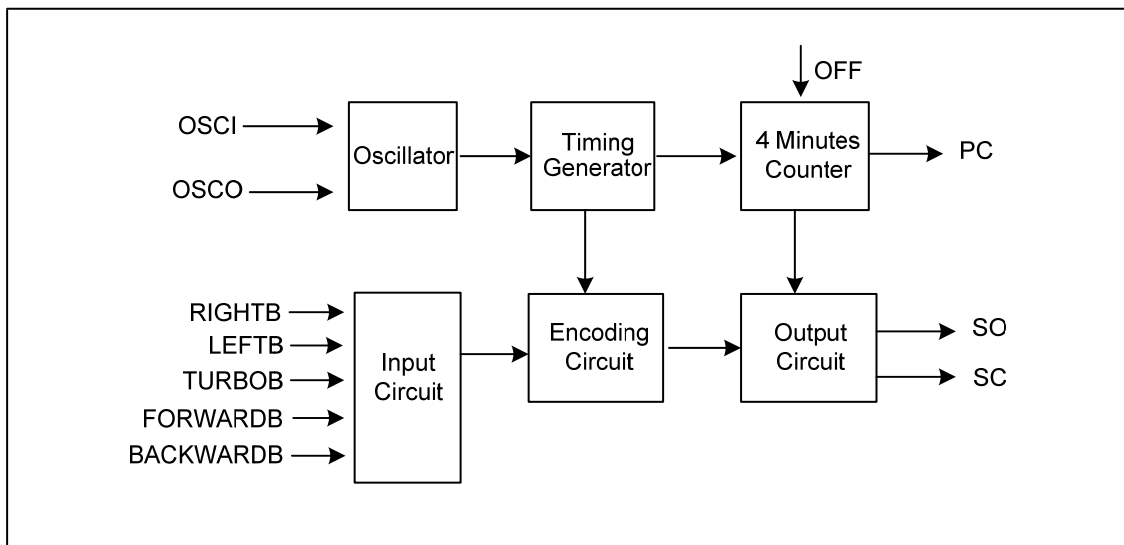

■ ABSOLUTE MAXIMUM RATINGS

PARAMETER	SYMBOL	VALUE	UNIT
DC Input Voltage	V_{IN}	-0.5 ~ +5.5	V
Supply Voltage to Ground Potential (Inputs & V_{DD} Only)		-0.5 ~ +5.5	V
Supply Voltage to Ground Potential (Outputs & D/O Only)		-0.5 ~ +5.5	V
DC Output Current	I_{OUT}	20	mA
Power Dissipation	P_D	500	mW
Ambient Temperature With Power Applied	T_A	-10 ~ +40	°C
Storage Temperature	T_{STG}	-25 ~ +85	°C

■ DC ELECTRICAL CHARACTERISTICS

(Over the operating rating, $T_A = -10^{\circ}\text{C} \sim +40^{\circ}\text{C}$, $V_{DD} = 4.0\text{V} \pm 10\%$)

PARAMETER	SYMBOL	TEST CONDITIONS	MIN	TYP	MAX	UNIT
Operating Voltage	V_{DD}		2.5	4.0	5.0	V
Input Low Voltage	V_{IL}	Guaranteed Logic Low Level			0.5	V
Output High Voltage	V_{OH}	$I_{OUT} = 1.0\text{mA}$	3.5			V
Output Low Voltage	V_{OL}	$I_{OUT} = 150\mu\text{A}$			0.5	V
Output High Current	I_{OH}	$V_{OUT} = 1.4\text{V}$	-4.0			mA
Supply Current	I_{DD}	Output unloaded			300	μA
Standby Current	I_{STB}	OFF state			10	μA
Input Current	I_{IN}	Pin 1,4,5,6,14			60	μA
Output Low Current	I_{OL}	$V_{OUT} = 0.5\text{V}$	150			μA

■ AC ELECTRICAL CHARACTERISTICS

(Over the operating rating, $T_A = -10^{\circ}\text{C} \sim +40^{\circ}\text{C}$, $V_{DD} = 4.0\text{V} \pm 10\%$)

PARAMETER	SYMBOL	TEST CONDITIONS	MIN	TYP	MAX	UNIT
Oscillator Frequency ^(Note 1)	F_{OSC}	$T_A = 25^{\circ}\text{C}$, $R = 200\text{K}\Omega$	102	128	154	KHz
Carrier Frequency of SC Pin	F_{CSC}	$F_{OSC} = 102 \sim 154\text{KHz}$	51	64	77	KHz
Time of Auto-Power-Off ^(Note 2)	T_{OFF*}	$F_{OSC} = 102 \sim 154\text{KHz}$	3.2	4	4.8	min.
Cycle Time of Function Code	T_{FUN}	$F_{OSC} = 102 \sim 154\text{KHz}$	0.8	1	1.2	ms
Cycle Time of Start Code	T_{STA}	$F_{OSC} = 102 \sim 154\text{KHz}$	1.6	2.1	2.4	ms

Note: 1. The relative error between the frequencies of the two on-chip oscillators in the UTC RCT02 and UTC RCR02 must be less than $\pm 25\%$.

2. When adjust the external oscillator resistor, the auto-power-off time will vary relevantly.

■ CODE FORMAT (W1 is used for function codes, W2 for start codes)

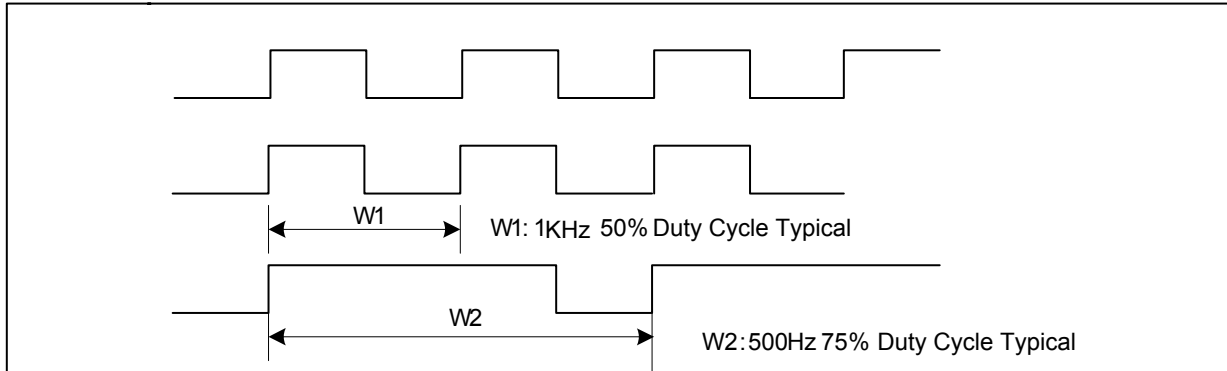

■ WORD FORMAT

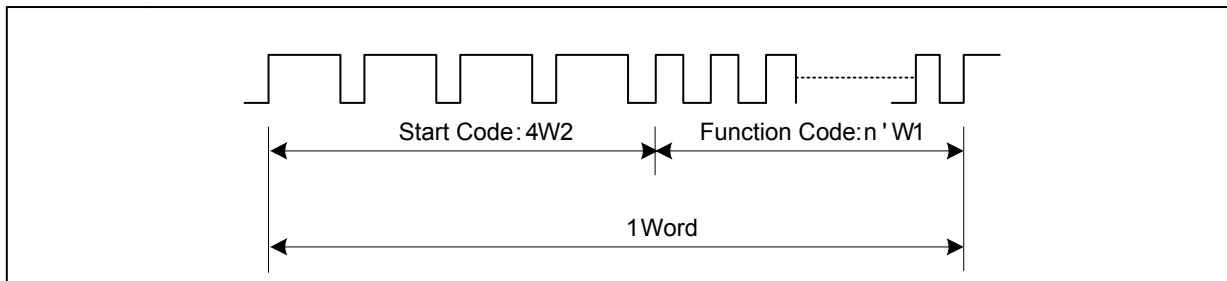

■ ENCODING TIMING

W2 W2 W2 W2 (n)' W1 W2 W2 W2 W2 (n)' W1 W2 W2 W2 W2 (n)' W1 W2 W2 W2 W2 (n)' W1-----

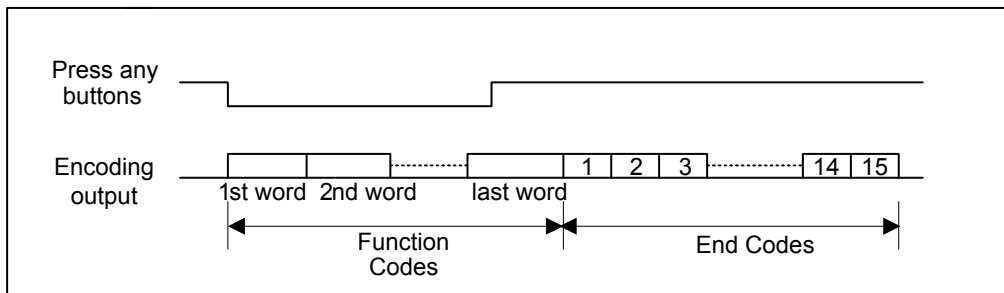

Number of Function Codes (n) W1	Function Buttons
4	(End Code)
10	Forward
16	Forward & Turbo
22	Turbo
28	(Turbo/Forward) & Left
34	(Turbo/Forward) & Right
40	Backward
46	Backward & Right
52	Backward & Left
58	Left
64	Right

■ PC OUTPUT TIMING

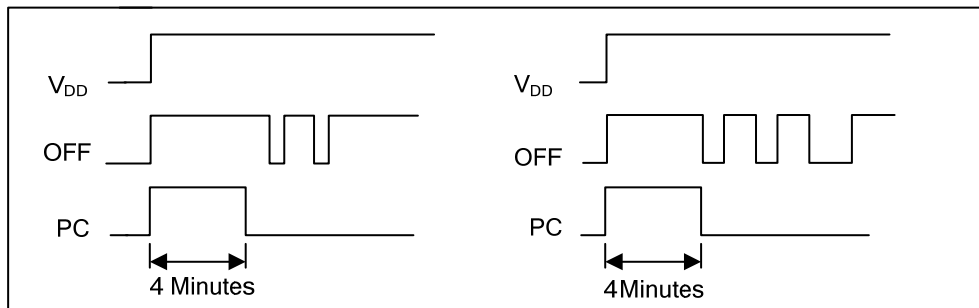

Note: There is no press on any function button.

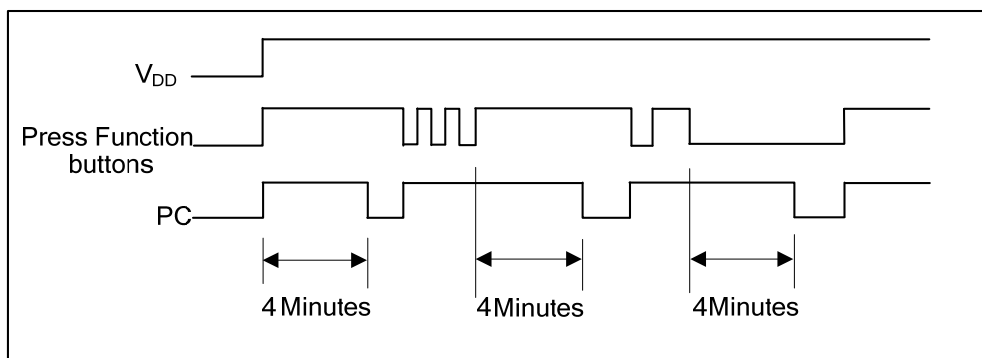

■ BLOCK DIAGRAM OF APPLICATION CIRCUIT (1)

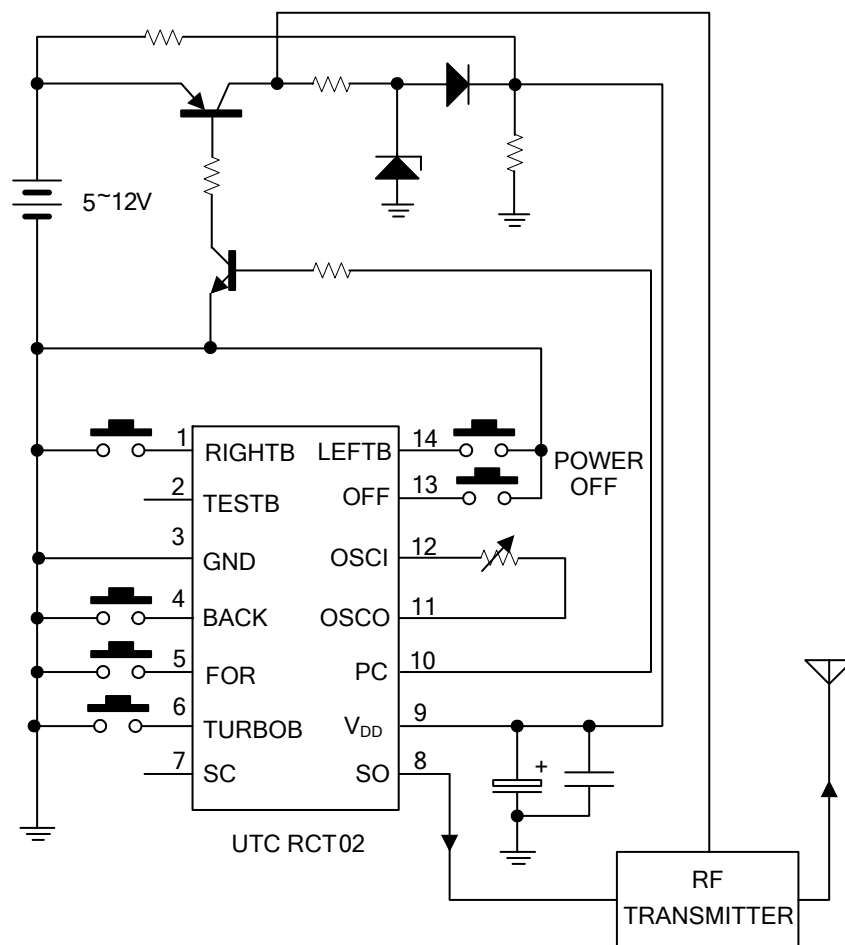

Note: 1. The power supply for above circuit should be 5.0V ~ 12V.
 2. This circuit is for wireless application.

■ BLOCK DIAGRAM OF APPLICATION CIRCUIT (2)

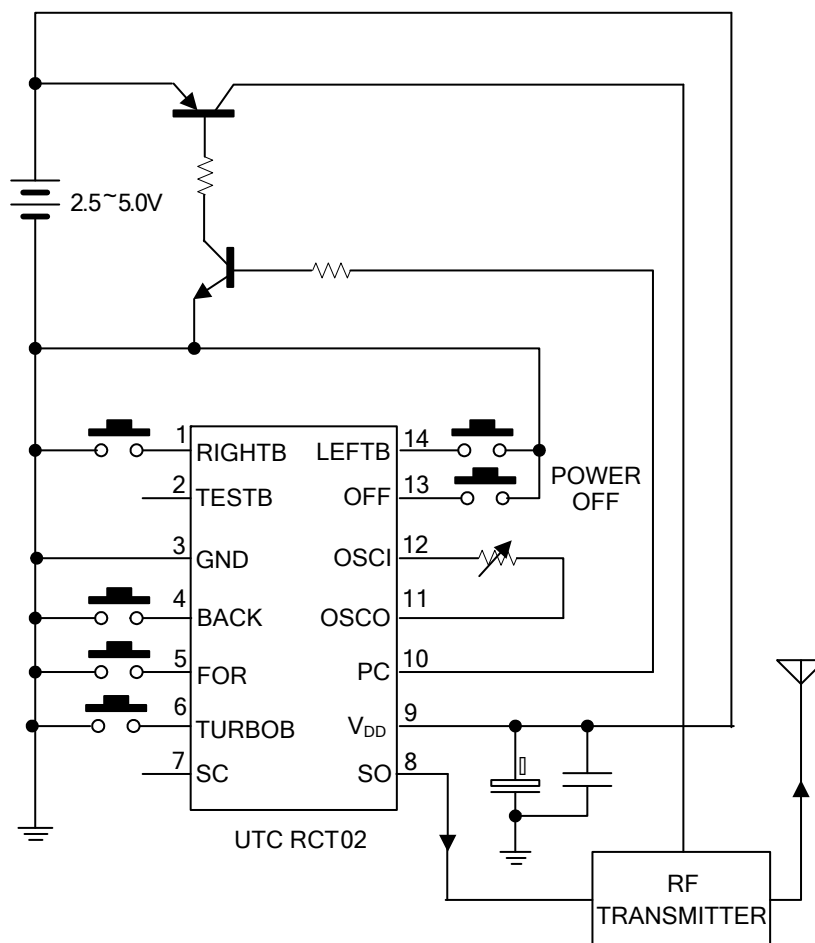

Note: 1. The power supply for above circuit should be 2.5V ~ 5.0V.
 2. This circuit is for wireless application.

■ BLOCK DIAGRAM OF APPLICATION CIRCUIT (3)

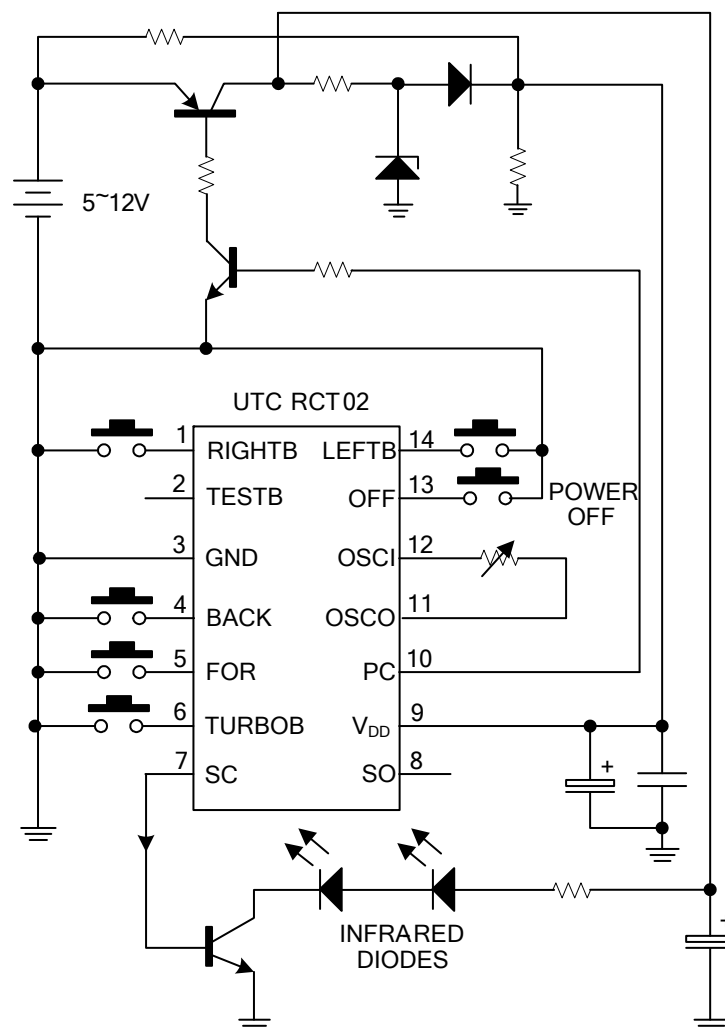

- Note: 1. The power supply for above circuit should be 5.0V ~ 12V.
 2. This circuit is for infra-red application.

■ BLOCK DIAGRAM OF APPLICATION CIRCUIT (4)

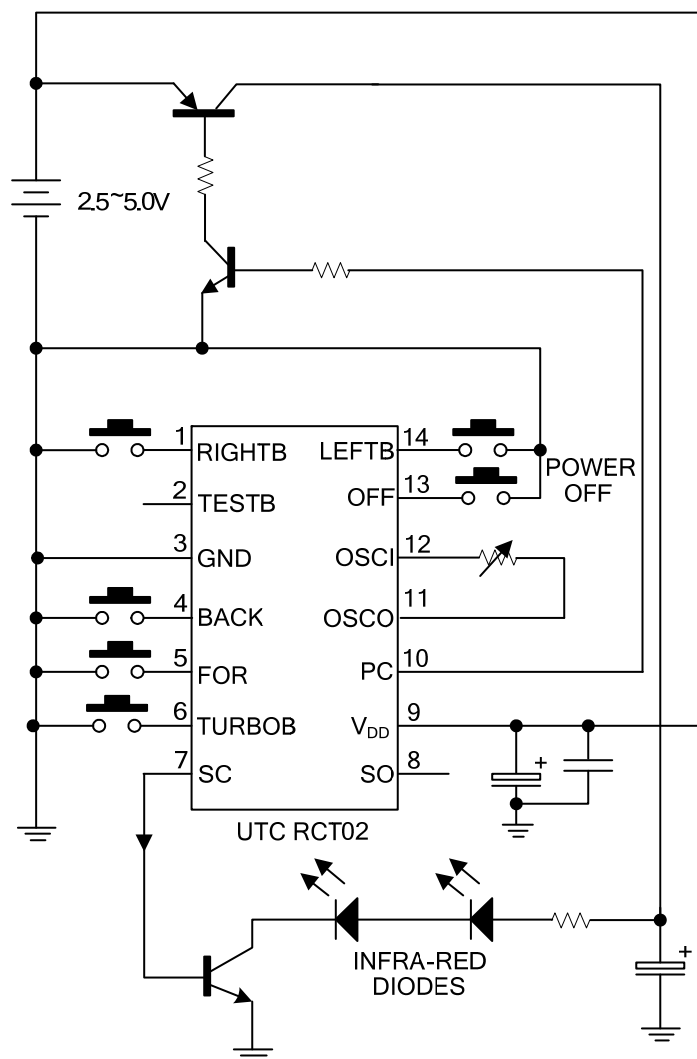

Note: 1. The power supply for above circuit should be 2.5V~ 5.0V.
 2. This circuit is for infra -red application.

■ TYPICAL APPLICATION FOR TRANSMIT CIRCUIT WITH 9V BATTERY

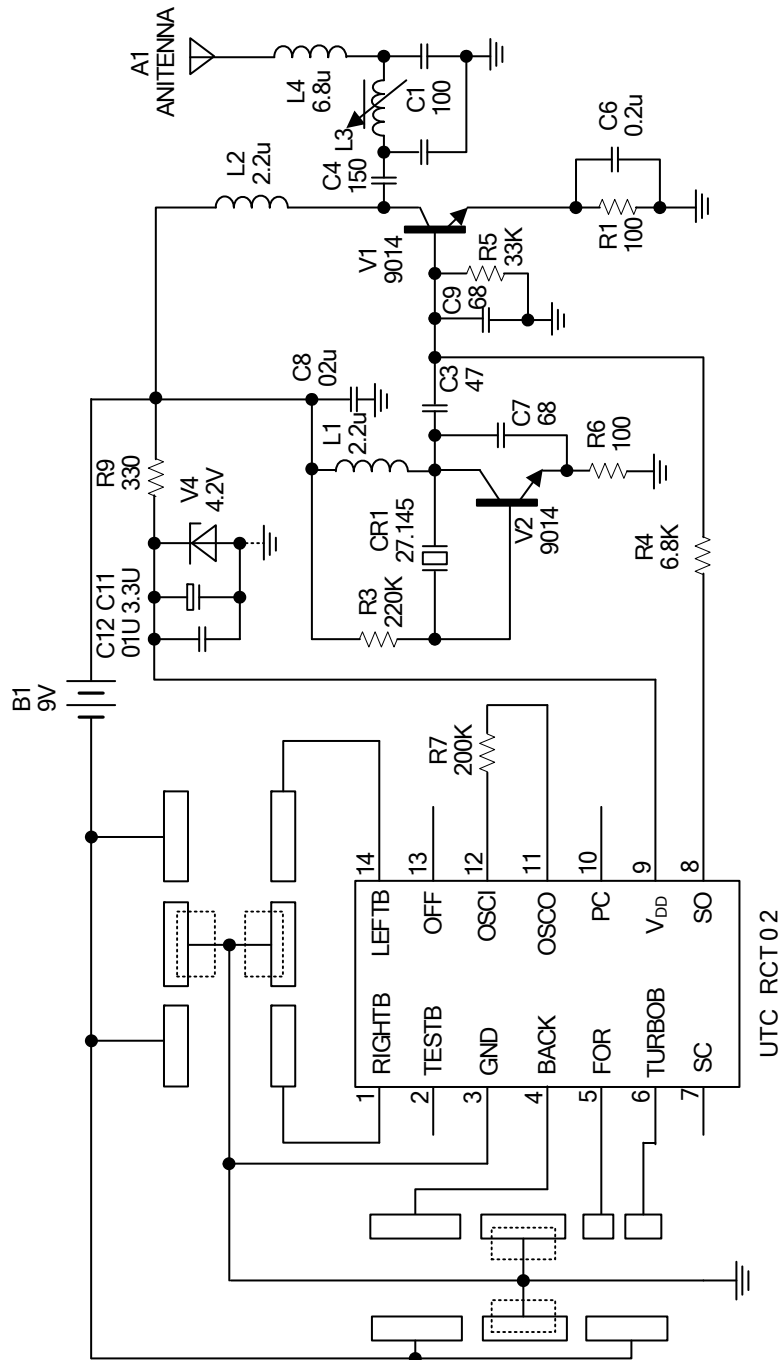

UTC assumes no responsibility for equipment failures that result from using products at values that exceed, even momentarily, rated values (such as maximum ratings, operating condition ranges, or other parameters) listed in products specifications of any and all UTC products described or contained herein. UTC products are not designed for use in life support appliances, devices or systems where malfunction of these products can be reasonably expected to result in personal injury. Reproduction in whole or in part is prohibited without the prior written consent of the copyright owner. The information presented in this document does not form part of any quotation or contract, is believed to be accurate and reliable and may be changed without notice.