



RCT2E

CMOS IC

ENCODER FOR REMOTE CONTROLLER WITH FIVE FUNCTIONS

DESCRIPTION

The UTC **RCT2E** can be used with the decoder UTC RCR2C to provide a complete control functions to the remote-controlled toy. The UTC **RCT2E** is the transmitter. It is provide five function keys to control forward, Backward, Rightward, Leftward and Turbo motions. Beside, a combination of these five motions can be played.

UTC **RCT2E** is built with auto Power-OFF function. When input key is pulled low, UTC **RCT2E** will wake up, SC and SO will continuously send out code in RF format (Non-Carrier) and IR format (Carrier). However, when a complete code is sent out and the key is released, UTC **RCT2E** will automatically go into powered-off mode.

FEATURES

- * Wide and Low operating voltage range: 1.8V ~ 5.0V
- * 5-function remote controller controlling forward/ backward/ turbo/ right/ left.
- * Provide two transmissive interface (RF and IR) for different application.
- * Auto Power-OFF function
- * Few external components needed and Oscillator with an external resistor.
- * Low Standby current and low operating current.
- * Long distance Remote Control to 100M in UTC **RCT2E** and UTC RCR2C pairing.
- * Typical oscillator frequency:
 - RF: 116 ~ 140KHz.
 - IR: 114KHz (Carrier Frequency: 57KHz).
 - IR: 76KHz (Carrier Frequency: 38KHz).

ORDERING INFORMATION

Ordering Number		Package	Packing
Lead Free	Halogen Free		
RCT2EL-D14-T	RCT2EG-D14-T	DIP-14	Tube
-	RCT2EG-S08-R	SOP-8	Tape Reel

<p>RCT2EL-D14-T</p> <ul style="list-style-type: none"> (1)Packing Type (2)Package Type (3)Green Package 	<ul style="list-style-type: none"> (1) T: Tube, R: Tape Reel (2) D14: DIP-14, S08: SOP-8 (3) L: Lead Free, G: Halogen Free and Lead Free
--	---

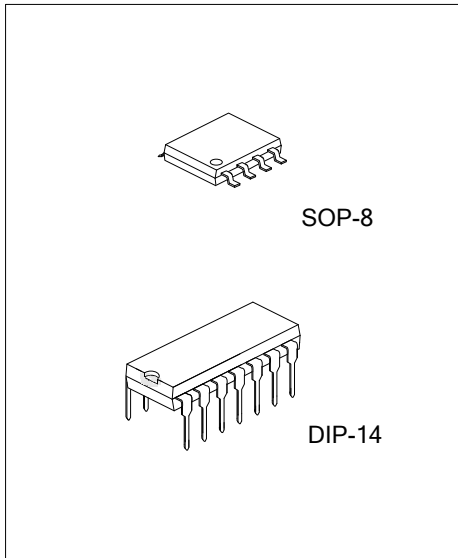

MARKING

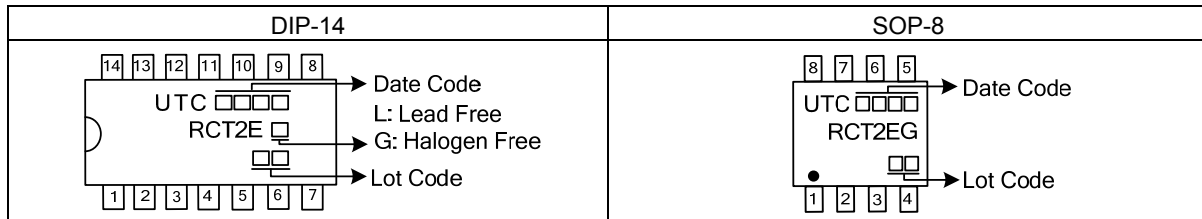

PIN CONFIGURATION

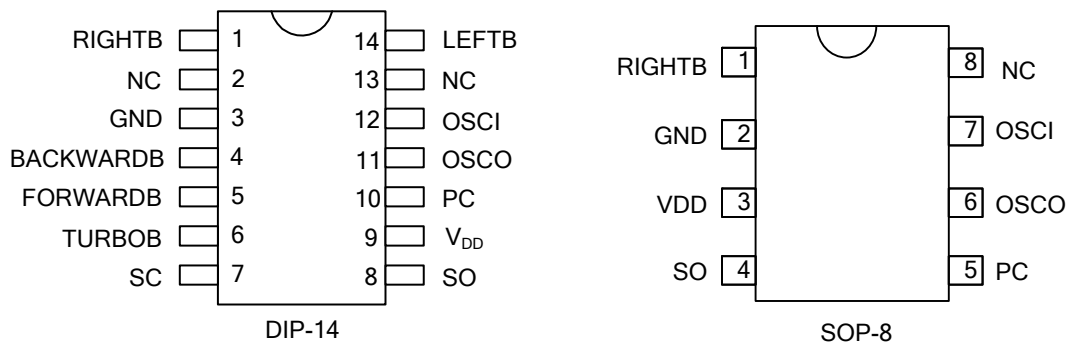

PIN DESCRIPTION

PIN NO.	PIN NAME	FUNCTION
1	RIGHTTB	The rightward function will be selected when this pin is connected to GND.
2	NC	No connection
3	GND	Negative power supply
4	BACKWARDB	The backward function will be selected when this pin is connected to GND.
5	FORWARDB	The forward function will be selected when this pin is connected to GND.
6	TURBOB	The turbo function will be selected when this pin is connected to GND.
7	SC	Output pin of the encoding signal with carrier frequency
8	SO	Output pin of the encoding signal without carrier frequency
9	V _{DD}	Positive power supply
10	PC	Power control output pin. When any function key is pulled low, PC will be high logic.
11	OSCO	Oscillator output pin
12	OSCI	Oscillator input pin
14	LEFTTB	The leftward function will be selected when this pin is connected to GND.

BLOCK DIAGRAM

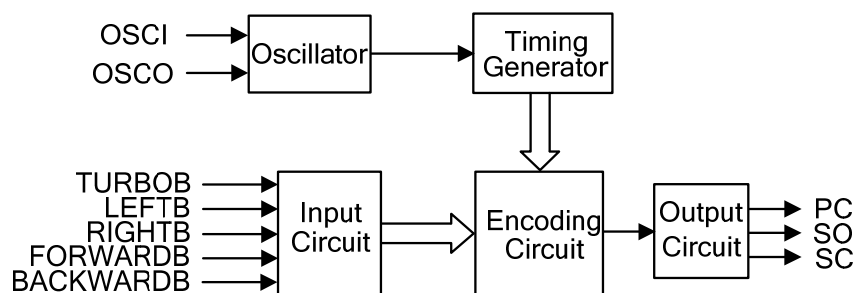

■ ABSOLUTE MAXIMUM RATINGS

PARAMETER	SYMBOL	RATINGS	UNIT
DC Supply Voltage	V_{DD}	-0.3 ~ 6.0	V
Input/Output Voltage		GND -0.2 ~ $V_{DD}+0.2$	V
Operating Temperature	T_{OPR}	-10 ~ 60	°C
Storage Temperature	T_{STG}	-25 ~ 125	°C

■ ELECTRICAL CHARACTERISTICS

($V_{DD}=4.5V$, $F_{osc}=116\sim 140KHz$, $T_A=25^\circ C$, unless otherwise specified.)

PARAMETER	SYMBOL	TEST CONDITIONS	MIN	TYP	MAX	UNIT
Supply Voltage	V_{DD}		1.8	4.5	5.0	V
Input Low Voltage	V_{iL}	Function Input Pin			2.3	V
Operating Current	I_{DD}	Unload			0.6	mA
SO Driving Current	I_{DrSO}	Load=0.7V	6.5			mA
SC Driving Current	I_{DrSC}	Load=0.7V	6.5			mA
PC Driving Current	I_{DrPC}	Load=0.7V	6.5			mA
Stand by Current	$I_{StandBy}$	Unload			10	μA
Oscillator Frequency Tolerance	$F_{tolerance}$	UTC RCR2C $F_{OSC}=128KHz$	-20		+20	%

■ TYPICAL APPLICATION CIRCUIT

Transmitter ($F_{osc} = 116 \sim 140$ KHz)

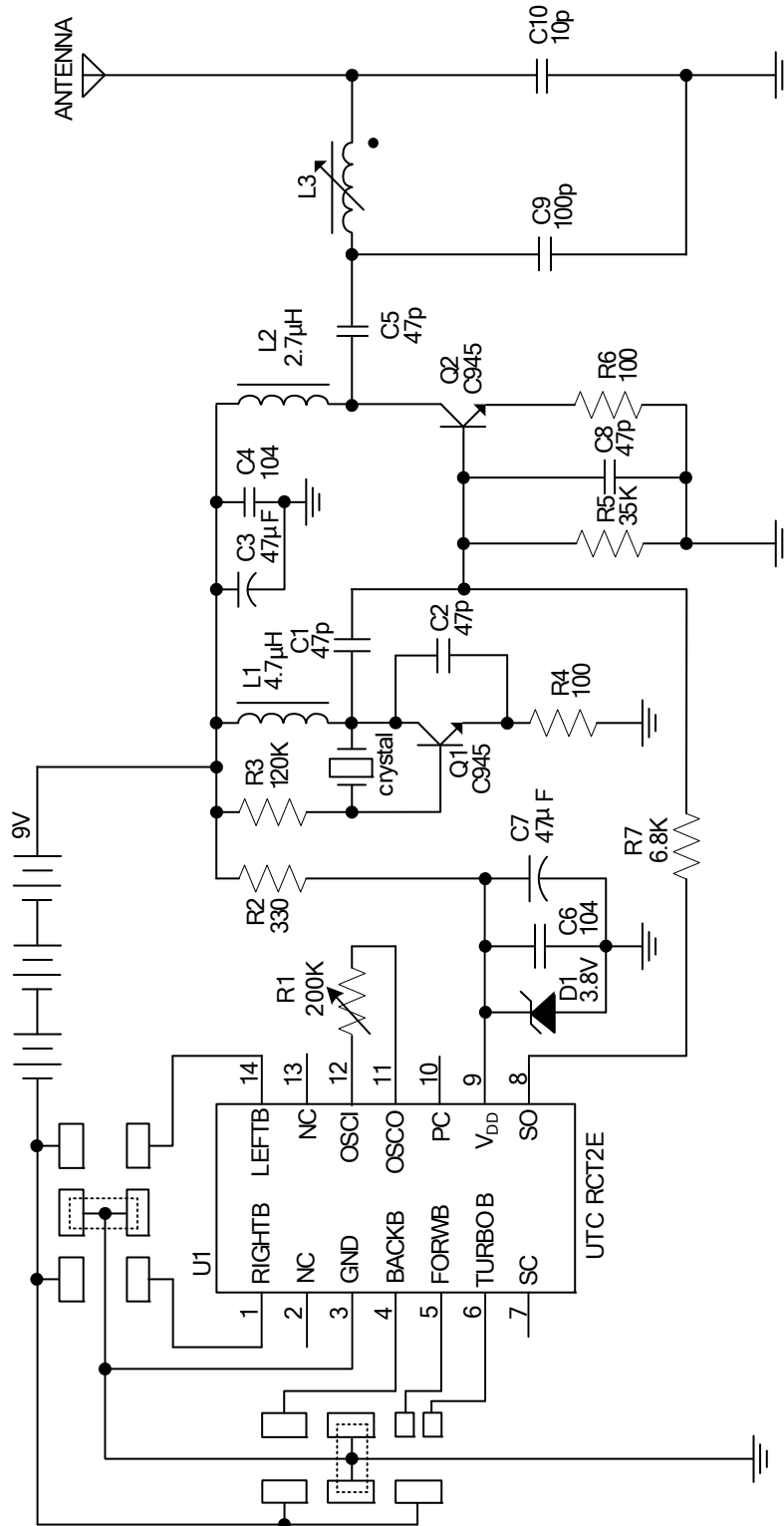

■ INFRARED APPLICATION CIRCUIT

Transmitter ($F_{osc} = 114 \text{ KHz}$)

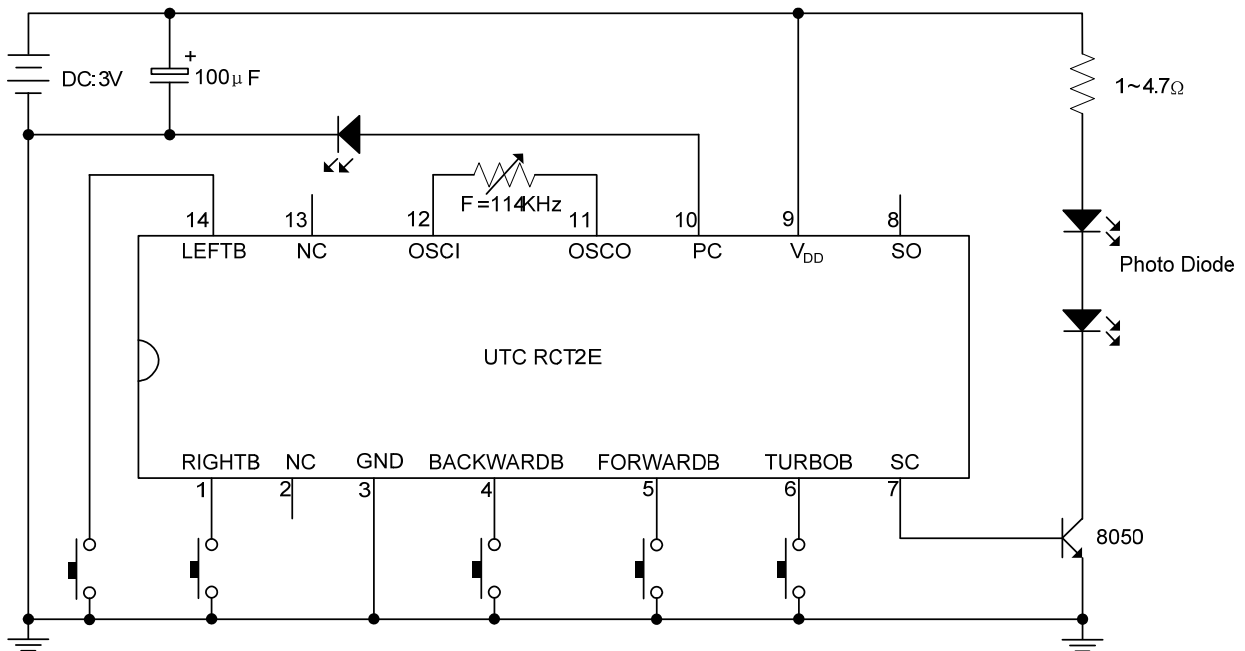

■ TESTING CIRCUIT

The oscillator frequency is 116 ~140KHz

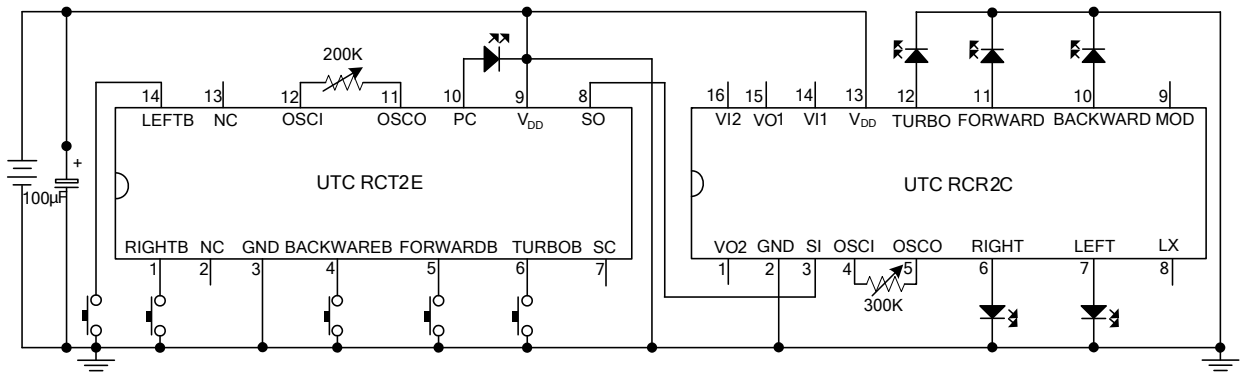

UTC assumes no responsibility for equipment failures that result from using products at values that exceed, even momentarily, rated values (such as maximum ratings, operating condition ranges, or other parameters) listed in products specifications of any and all UTC products described or contained herein. UTC products are not designed for use in life support appliances, devices or systems where malfunction of these products can be reasonably expected to result in personal injury. Reproduction in whole or in part is prohibited without the prior written consent of the copyright owner. The information presented in this document does not form part of any quotation or contract, is believed to be accurate and reliable and may be changed without notice.