



U74AHC157

CMOS IC

QUADRUPLE 2-LINE TO 1-LINE DATA SELECTORS / MULTIPLEXERS

DESCRIPTION

The **U74AHC157** is a quadruple 2-line to 1-line data selector/multiplexer. When \bar{G} is high all outputs are low. When \bar{G} is low a 4-bit word is selected from one of two sources and is routed to the four outputs. The device provides true data.

FEATURES

- * Wide supply voltage range from 2V to 5.5V
- * Max t_{PD} of 4.1ns from A or B to Y at 5V, $C_L=15pF$
- * Low power consumption, $I_{CC} = 4 \mu A$ (MAX) at 5.5V
- * ± 8 mA output driver at 5V

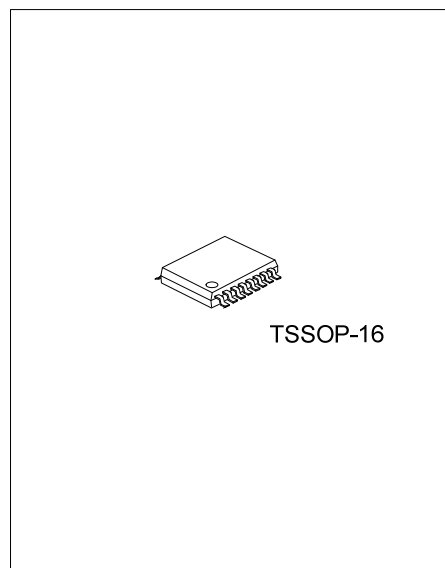

ORDERING INFORMATION

Ordering Number		Package	Packing
Lead Free	Halogen Free		
U74AHC157L-P16-R	U74AHC157G-P16-R	TSSOP-16	Tape Reel

<p>U74AHC157G-P16-R</p> <p>(1)Packing Type (2)Package Type (3)Green Package</p>	<p>(1) R: Tape Reel (2) P16: TSSOP-16 (3) G: Halogen Free and Lead Free, L: Lead Free</p>
---	---

MARKING

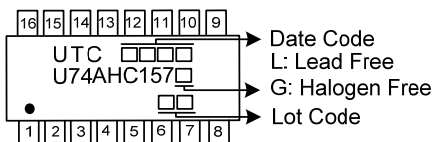

■ PIN CONFIGURATION

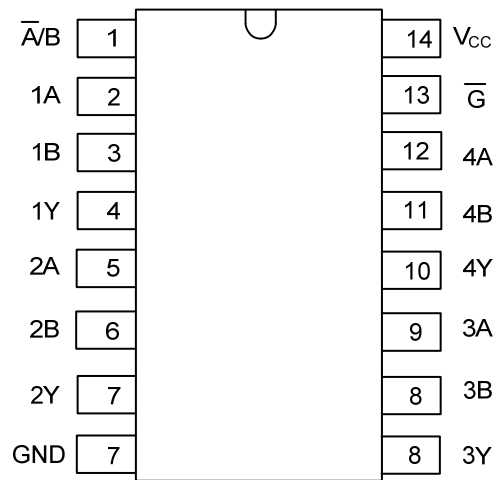

■ FUNCTION TABLE

INPUTS				OUTPUTS
\bar{G}	\bar{A}/B	A	B	Y
H	X	X	X	L
L	L	L	X	L
L	L	H	X	H
L	H	X	L	L
L	H	X	H	H

■ LOGIC DIAGRAM

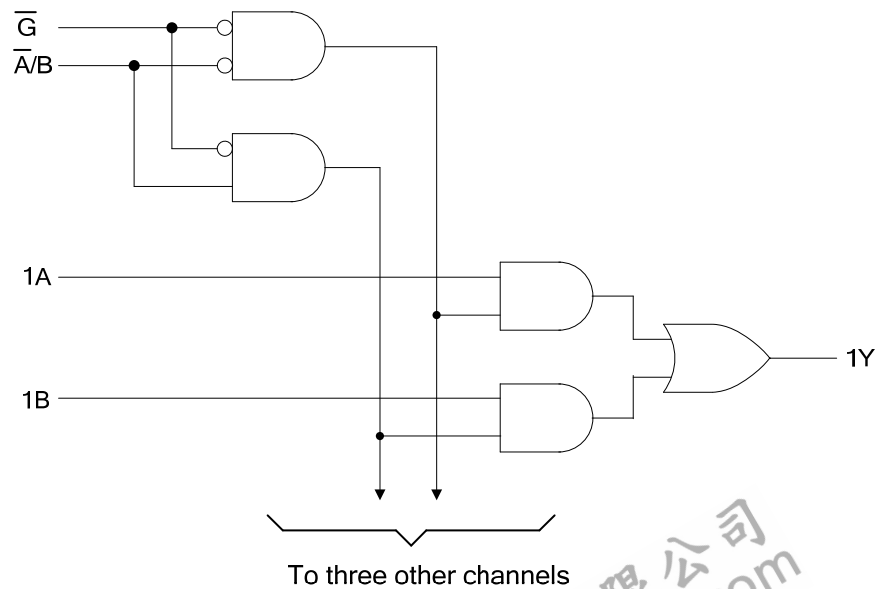

■ ABSOLUTE MAXIMUM RATING (T_A =25°C , unless otherwise specified)

PARAMETER	SYMBOL	RATINGS	UNIT
Supply Voltage Range	V _{CC}	-0.5~7	V
Input Voltage Range	V _{IN}	-0.5~7	V
Output Voltage Range	V _{OUT}	-0.5~V _{CC} +0.5	V
Input Clamp Current (V _{IN} <0)	I _{IK}	-20	mA
Output Clamp Current (V _{OUT} <0, or V _{OUT} >V _{CC})	I _{OK}	±20	mA
Output Current	I _{OUT}	±25	mA
V _{CC} or GND Current	I _{CC}	±50	mA
Storage Temperature	T _{STG}	-65 ~ +150	°C

Note: 1. The input and output voltage ratings may be exceeded if the input and output current ratings are observed.

2. Absolute maximum ratings are those values beyond which the device could be permanently damaged.

Absolute maximum ratings are stress ratings only and functional device operation is not implied.

■ RECOMMENDED OPERATING CONDITIONS

PARAMETER	SYMBOL	CONDITIONS	MIN	TYP	MAX	UNIT
Supply Voltage	V _{CC}		2		5.5	V
High-Level Input Voltage	V _{IH}	V _{CC} = 2V	1.5			V
		V _{CC} = 3V	2.1			
		V _{CC} = 5.5V	3.85			
Low-Level Input Voltage	V _{IL}	V _{CC} = 2V			0.5	V
		V _{CC} = 3V			0.9	
		V _{CC} = 5.5V			1.65	
Input Voltage	V _{IN}		0		5.5	V
Output Voltage	V _{OUT}		0		V _{CC}	V
High-level Output Current	I _{OH}	V _{CC} = 2V			-50	μA
		V _{CC} = 3.3±0.3V			-4	mA
		V _{CC} = 5±0.5V			-8	
Low-level Output Current	I _{OL}	V _{CC} = 2V			50	μA
		V _{CC} = 3.3±0.3V			4	mA
		V _{CC} = 5±0.5V			8	
Input Transition Rise or Fall Rate	Δt/ΔV	V _{CC} = 3.3±0.3V			100	ns/V
		V _{CC} = 5±0.5V			20	
Operating Temperature	T _A		-40		85	°C

■ ELECTRICAL CHARACTERISTICS (T_A =25°C , unless otherwise specified)

PARAMETER	SYMBOL	TEST CONDITIONS	MIN	TYP	MAX	UNIT
High-Level Output Voltage	V _{OH}	I _{OH} = -50 μA, V _{CC} = 2V	1.9	2		V
		I _{OH} = -50 μA, V _{CC} = 3V	2.9	3		
		I _{OH} = -50 μA, V _{CC} = 4.5V	4.4	4.5		
		I _{OH} = -4 mA, V _{CC} = 3V	2.58			
		I _{OH} = -8 mA, V _{CC} = 4.5V	3.94			
Low-Level Output Voltage	V _{OL}	I _{OL} = 50 μA, V _{CC} = 2V			0.1	V
		I _{OL} = 50 μA, V _{CC} = 3V			0.1	
		I _{OL} = 50 μA, V _{CC} = 4.5V			0.1	
		I _{OL} = 4 mA, V _{CC} = 3V			0.36	
		I _{OL} = 8 mA, V _{CC} = 4.5V			0.36	
Input Leakage Current (A or B inputs)	I _{I(LEAK)}	V _{IN} = 5.5V or GND, V _{CC} = 0 to 5.5V			±0.1	μA
Quiescent Supply Current	I _{CC}	V _{IN} = V _{CC} or GND, I _{OUT} = 0, V _{CC} = 5.5V			4	μA
Input Capacitance	C _{IN}	V _{IN} = V _{CC} or GND, V _{CC} = 5V		2	10	pF

SWITCHING CHARACTERISTICS

$V_{CC} = 3.3V \pm 0.3V$, $T_A = 25^\circ C$

PARAMETER	SYMBOL	TEST CONDITIONS	MIN	TYP	MAX	UNIT
Propagation delay from input A or B to output Y, t_{pd}	t_{PLH}	$C_L=15pF, R_L=1k\Omega$		6.2	9.7	ns
		$C_L=50pF, R_L=1k\Omega$		8.7	13.2	
	t_{PHL}	$C_L=15pF, R_L=1k\Omega$		6.2	9.7	ns
		$C_L=50pF, R_L=1k\Omega$		8.7	13.2	
Propagation delay from input \bar{A}/B to output Y, t_{pd}	t_{PLH}	$C_L=15pF, R_L=1k\Omega$		8.4	13.2	Ns
		$C_L=50pF, R_L=1k\Omega$		10.9	16.7	
	t_{PHL}	$C_L=15pF, R_L=1k\Omega$		8.4	13.2	Ns
		$C_L=50pF, R_L=1k\Omega$		10.9	16.7	
Propagation delay from input \bar{G} to output Y, t_{pd}	t_{PLH}	$C_L=15pF, R_L=1k\Omega$		8.7	13.6	Ns
		$C_L=50pF, R_L=1k\Omega$		11.2	17.1	
	t_{PHL}	$C_L=15pF, R_L=1k\Omega$		8.7	13.6	Ns
		$C_L=50pF, R_L=1k\Omega$		11.2	17.1	

$V_{CC} = 5V \pm 0.5V$, $T_A = 25^\circ C$

PARAMETER	SYMBOL	TEST CONDITIONS	MIN	TYP	MAX	UNIT
Propagation delay from input A or B to output Y, t_{pd}	t_{PLH}	$C_L=15pF, R_L=1k\Omega$		4.1	6.4	ns
		$C_L=50pF, R_L=1k\Omega$		5.6	8.4	
	t_{PHL}	$C_L=15pF, R_L=1k\Omega$		4.1	6.4	ns
		$C_L=50pF, R_L=1k\Omega$		5.6	8.4	
Propagation delay from input \bar{A}/B to output Y, t_{pd}	t_{PLH}	$C_L=15pF, R_L=1k\Omega$		5.3	8.1	ns
		$C_L=50pF, R_L=1k\Omega$		6.8	10.1	
	t_{PHL}	$C_L=15pF, R_L=1k\Omega$		5.3	8.1	ns
		$C_L=50pF, R_L=1k\Omega$		6.8	10.1	
Propagation delay from input \bar{G} to output Y, t_{pd}	t_{PLH}	$C_L=15pF, R_L=1k\Omega$		5.6	8.6	ns
		$C_L=50pF, R_L=1k\Omega$		7.1	10.6	
	t_{PHL}	$C_L=15pF, R_L=1k\Omega$		5.6	8.6	ns
		$C_L=50pF, R_L=1k\Omega$		7.1	10.6	

OPERATING CHARACTERISTICS ($T_A = 25^\circ C$)

PARAMETER	SYMBOL	TEST CONDITIONS	RATINGS	UNIT
Power dissipation capacitance	C_{PD}	$V_{CC} = 5V, f=1MHz, No\ load$	11	pF

■ TEST CIRCUIT AND WAVEFORMS

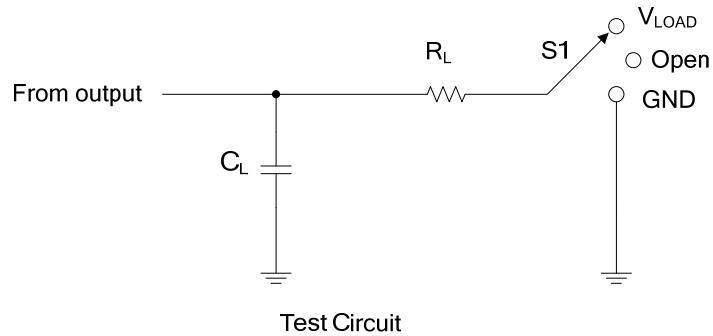

TEST	S1
t_{PLH}/t_{PHL}	Open
t_{PLZ}/t_{PZL}	V_{LOAD}
t_{PHZ}/t_{PZH}	GND

V_{CC}	Input		V_M	V_{LOAD}	C_L	R_L	V_{Δ}
	V_{IN}	t_R, t_F					
$3.3V \pm 0.3V$	V_{CC}	$\leq 3ns$	$V_{CC}/2$	V_{CC}	15pF	1k Ω	0.3V
					50pF		
$5V \pm 0.5V$	V_{CC}	$\leq 3ns$	$V_{CC}/2$	V_{CC}	15pF	1k Ω	0.5V
					50pF		

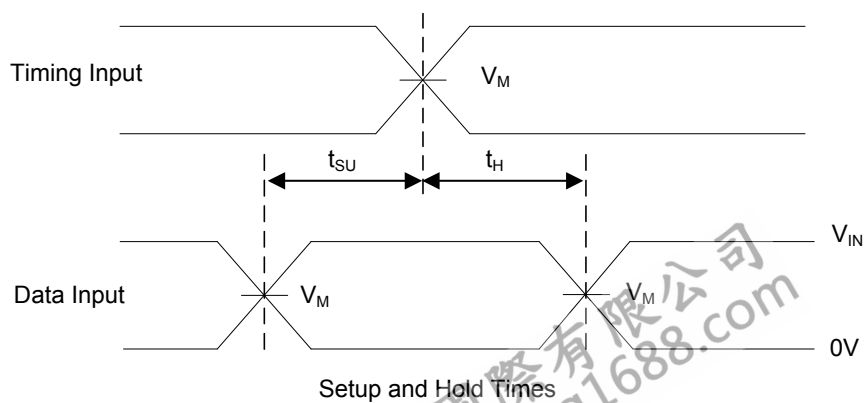
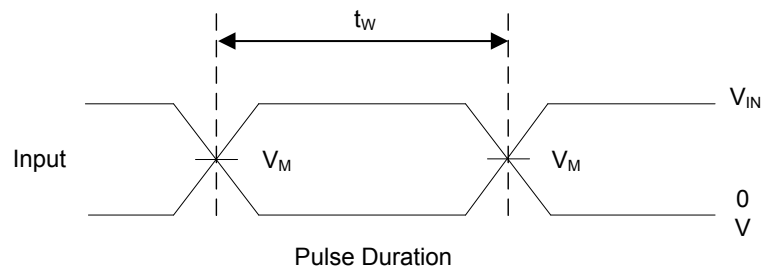

■ TEST CIRCUIT AND WAVEFORMS(Cont.)

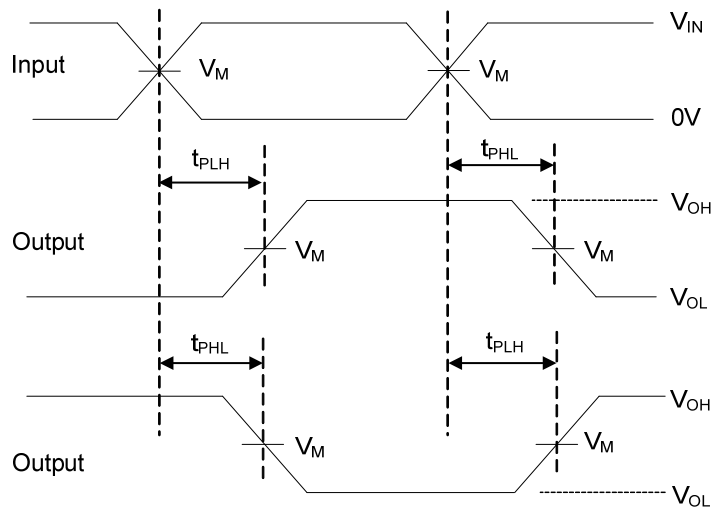

Voltage Waveforms Propagation Delay Times

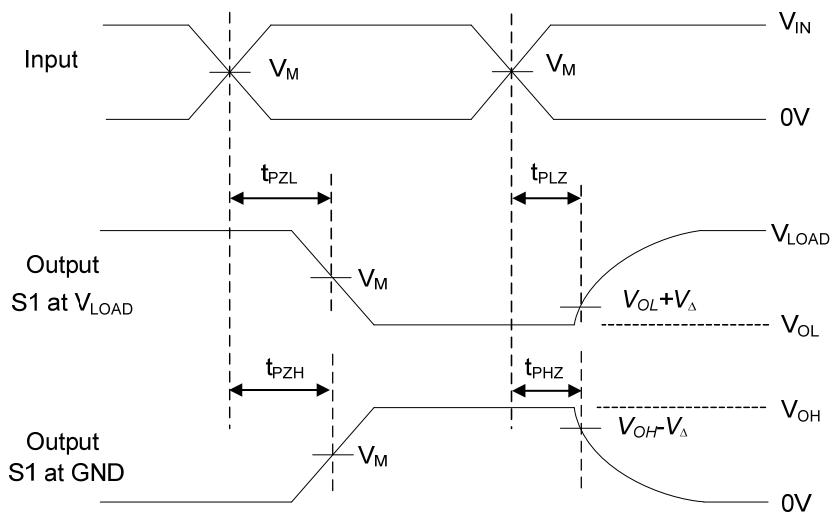

Voltage Waveforms Enable and Disable Times

Notes: 1. C_L includes probe and jig capacitance.

2. All input pulses are supplied by generators having the following characteristics: PRR ≤ 1 MHz, $Z_O = 50\Omega$.

UTC assumes no responsibility for equipment failures that result from using products at values that exceed, even momentarily, rated values (such as maximum ratings, operating condition ranges, or other parameters) listed in products specifications of any and all UTC products described or contained herein. UTC products are not designed for use in life support appliances, devices or systems where malfunction of these products can be reasonably expected to result in personal injury. Reproduction in whole or in part is prohibited without the prior written consent of the copyright owner. UTC reserves the right to make changes to information published in this document, including without limitation specifications and product descriptions, at any time and without notice. This document supersedes and replaces all information supplied prior to the publication hereof.