



U74AUC1G02

CMOS IC

SINGLE 2-INPUT NOR GATE

DESCRIPTION

The **U74AUC1G02** is a 2-input NOR gate which provides the function $Y = \overline{A+B}$ or $Y = \overline{A} \cdot \overline{B}$ in positive logic.

This device has power-down protective circuit, preventing device destruction when it is powered down.

FEATURES

- * Operate from 0.8V to 2.7V
- * Low power dissipation : $I_{CC} = 10\mu A$ (Max.)
- * $\pm 8mA$ Output Driver : $V_{CC} = 1.8V$
- * I_{off} Supports partial-Power-Down Mode Operation

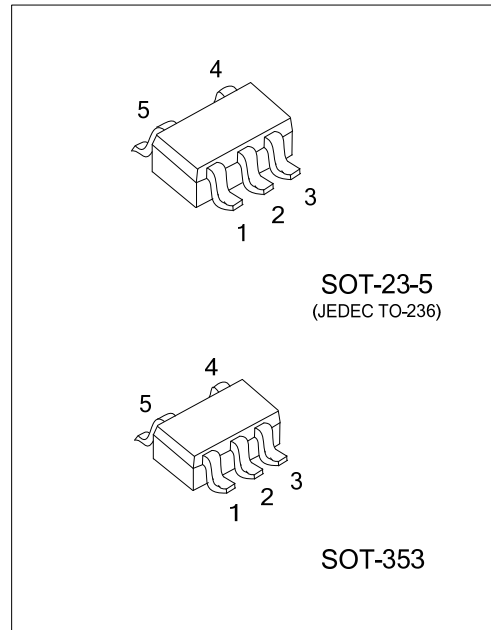

ORDERING INFORMATION

Ordering Number		Package	Packing
Lead Free	Halogen Free		
U74AUC1G02L-AE5-R	U74AUC1G02G-AE5-R	SOT-23-5	Tape Reel
U74AUC1G02L-AL5-R	U74AUC1G02G-AL5-R	SOT-353	Tape Reel

<p>U74AUC1G02G-AE5-R</p> <p>(1) Packing Type (2) Package Type (3) Green Package</p>	<p>(1) R: Tape Reel (2) AE5: SOT-23-5, AL5: SOT-353 (3) G: Halogen Free and Lead Free, L: Lead Free</p>
---	---

MARKING

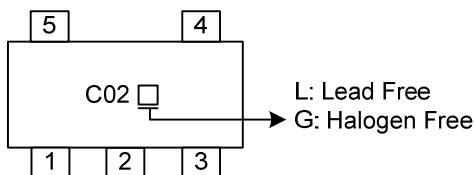

■ PIN CONFIGURATION

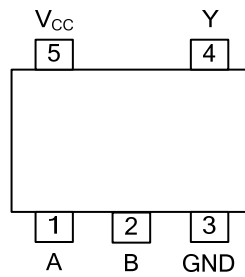

■ FUNCTION TABLE

INPUT(A)	INPUT(B)	OUTPUT(Y)
H	H	L
H	L	L
L	H	L
L	L	H

Note: H: HIGH voltage level; L: LOW voltage level.

■ LOGIC DIAGRAM (positive logic)

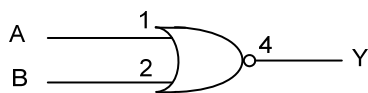

Logic symbol

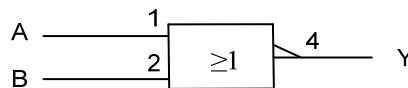

IEC logic symbol

FLYING 汎翔國際有限公司
www.flying1688.com

■ ABSOLUTE MAXIMUM RATING

PARAMETER	SYMBOL	TEST CONDITIONS	RATINGS	UNIT
Supply Voltage	V_{CC}		-0.5 ~ +3.6	V
Input Voltage	V_{IN}		-0.5 ~ +3.6	V
Output Voltage	V_{OUT}	Output in the high or low state	-0.5 ~ V_{CC} +0.5	V
		Output in the power-off state	-0.5 ~ +3.6	V
V_{CC} or GND Current	I_{CC}		±100	mA
Continuous Output Current	I_{OUT}	$V_{OUT}=0 \sim V_{CC}$	±20	mA
Input Clamp Current	I_{IK}	$V_{IN}<0$	-50	mA
Output Clamp Current	I_{OK}	$V_{OUT} >V_{CC}$ or $V_{OUT}<0$	-50	mA
Storage Temperature Range	T_{STG}		-65 ~ +150	°C

Note: Absolute maximum ratings are those values beyond which the device could be permanently damaged. Absolute maximum ratings are stress ratings only and functional device operation is not implied.

■ RECOMMENDED OPERATING CONDITIONS

PARAMETER	SYMBOL	TEST CONDITIONS	MIN	TYP	MAX	UNIT
Supply Voltage	V_{CC}	Operating	0.8		2.7	V
Input Voltage	V_{IN}		0		3.6	V
Output Voltage	V_{OUT}	High or low state	0		V_{CC}	V
Operating Temperature	T_A		-40		85	°C
Input Transition Rise or Fall Rate	$\Delta t/\Delta v$	$V_{CC}=0.8V \sim 1.95V$			20	ns/V
		$V_{CC}=2.3V \sim 2.7V$			10	ns/V

■ ELECTRICAL CHARACTERISTICS ($T_A=25^\circ C$, unless otherwise specified)

PARAMETER	SYMBOL	TEST CONDITIONS	MIN	TYP	MAX	UNIT
High-level Input Voltage	V_{IH}	$V_{CC}=0.8V$	V_{CC}			V
		$V_{CC}=1.1V \sim 1.95V$	$0.65 \times V_{CC}$			V
		$V_{CC}=2.3V \sim 2.7V$	1.7			V
Low-level Input Voltage	V_{IL}	$V_{CC}=0.8V$			V_{CC}	V
		$V_{CC}=1.1V \sim 1.95V$			$0.35 \times V_{CC}$	V
		$V_{CC}=2.3V \sim 2.7V$			0.7	V
High-Level Output Voltage	V_{OH}	$V_{CC}=0.8 \sim 2.7V, I_{OH}=-100\mu A$	$V_{CC}-0.1$			V
		$V_{CC}=0.8V, I_{OH}=-700\mu A$		0.55		V
		$V_{CC}=1.1V, I_{OH}=-3mA$	0.8			V
		$V_{CC}=1.4V, I_{OH}=-5mA$	1			V
		$V_{CC}=1.65V, I_{OH}=-8mA$	1.2			V
Low-Level Output Voltage	V_{OL}	$V_{CC}=0.8 \sim 2.7V, I_{OL}=100\mu A$			0.2	V
		$V_{CC}=0.8V, I_{OL}=700\mu A$		0.25		V
		$V_{CC}=1.1V, I_{OL}=3mA$			0.3	V
		$V_{CC}=1.4V, I_{OL}=5mA$			0.4	V
		$V_{CC}=1.65V, I_{OL}=8mA$			0.45	V
Input Leakage Current	$I_{I(LEAK)}$	$V_{CC}=0 \sim 2.7V, V_{IN}=V_{CC}$ or GND		±0.1	±5	μA
		$V_{CC}=0V, V_{IN}=V_O$ or 2.7V		±0.1	±10	μA
Quiescent Supply Current	I_{CC}	$V_{CC}=0.8 \sim 2.7V, V_{IN}=V_{CC}$ or GND $I_{OUT}=0$		0.1	10	μA
Input Capacitance	C_I	$V_{CC}=2.5V, V_{IN}=V_{CC}$ or GND		3		pF

■ SWITCHING CHARACTERISTICS (T_A =25°C , unless otherwise specified)

PARAMETER	SYMBOL	TEST CONDITIONS	MIN	TYP	MAX	UNIT	
Propagation delay from input (A or B) to output(Y)	t _{PLH} / t _{PHL}	C _L =15pF, R _L =2KΩ	V _{CC} =0.8V		4.6		ns
			V _{CC} =1.2±0.1V	0.9			ns
			V _{CC} =1.5±0.1V	0.5			ns
			V _{CC} =1.8±0.15V	0.4	1		ns
			V _{CC} =2.5±0.2V	0.2			ns
		C _L =30pF, R _L =1KΩ	V _{CC} =1.8±0.15V	0.7	1.3		ns
C _L =30pF, R _L =500Ω	V _{CC} =2.5±0.2V	0.5	1.2		ns		

■ OPERATING CHARACTERISTICS (f=10MHz, T_A =25°C , unless otherwise specified)

PARAMETER	SYMBOL	TEST CONDITIONS	MIN	TYP	MAX	UNIT
Power Dissipation Capacitance	C _{PD}	V _{CC} =0.8V		15		pF
		V _{CC} =1.2V		15		pF
		V _{CC} =1.5V		15		pF
		V _{CC} =1.8V		15		pF
		V _{CC} =2.5V		19		pF

FLYING 汎翔國際有限公司
 www.flying1688.com

■ TEST CIRCUIT AND WAVEFORMS

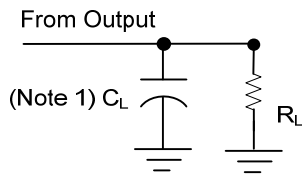

TEST CIRCUIT

V_{CC}	C_L	R_L	V_M
0.8V	15pF	2k Ω	$V_{CC}/2$
1.2V \pm 0.1V	15pF	2k Ω	$V_{CC}/2$
1.5V \pm 0.1V	15pF	2k Ω	$V_{CC}/2$
1.8V \pm 0.15V	15pF	2k Ω	$V_{CC}/2$
2.5V \pm 0.2V	15pF	2k Ω	$V_{CC}/2$
1.8V \pm 0.15V	30pF	1k Ω	$V_{CC}/2$
2.5V \pm 0.2V	30pF	500 Ω	$V_{CC}/2$

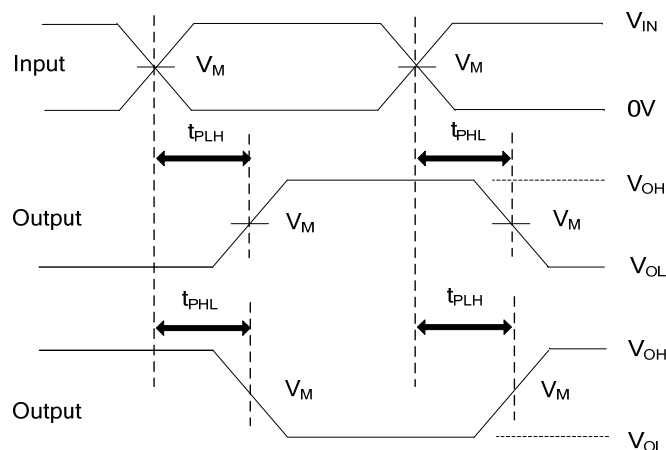

PROPAGATION DELAY TIMES

- Notes: 1. C_L includes probe and jig capacitance.
 2. All input pulses are supplied by generators having the following characteristics: PRR \leq 10MHz, $Z_O = 50\Omega$.

UTC assumes no responsibility for equipment failures that result from using products at values that exceed, even momentarily, rated values (such as maximum ratings, operating condition ranges, or other parameters) listed in products specifications of any and all UTC products described or contained herein. UTC products are not designed for use in life support appliances, devices or systems where malfunction of these products can be reasonably expected to result in personal injury. Reproduction in whole or in part is prohibited without the prior written consent of the copyright owner. UTC reserves the right to make changes to information published in this document, including without limitation specifications and product descriptions, at any time and without notice. This document supersedes and replaces all information supplied prior to the publication hereof.