



U74AUP1G00

CMOS IC

SINGLE 2-INPUT NAND GATE

DESCRIPTION

The **U74AUP1G00** is a 2-input NAND gate which provides the Function $Y=A \cdot B$ or $Y=\overline{A + B}$ in positive logic.

This device ensures a very low static and dynamic power consumption across the entire V_{CC} range from 0.8V to 3.6V.

This device has power-down protective circuit, preventing device destruction when it is powered down.

FEATURES

- * Wide supply voltage range from 0.8V to 3.6V
- * Inputs accept voltages up to 3.6V
- * I_{OFF} supports partial-power-down mode
- * Low static power consumption; $I_{CC}=0.5\mu A$ (Max.)
- * Optimized for 3.3V Operation

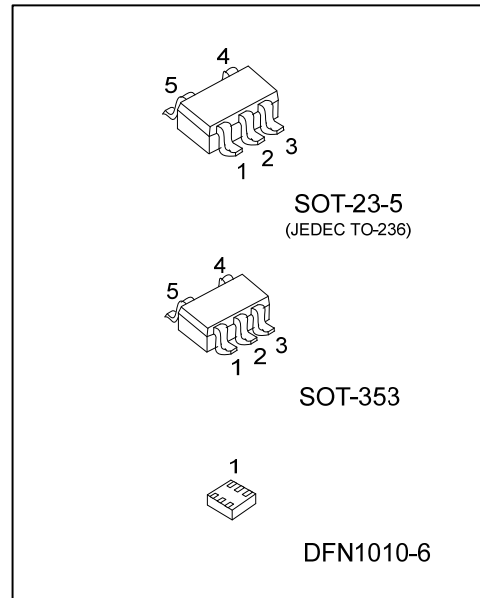

ORDERING INFORMATION

Ordering Number		Package	Packing
Lead Free	Halogen Free		
U74AUP1G00L-AE5-R	U74AUP1G00G-AE5-R	SOT-23-5	Tape Reel
U74AUP1G00L-AL5-R	U74AUP1G00G-AL5-R	SOT-353	Tape Reel
U74AUP1G00L-K06-1010-R	U74AUP1G00G-K06-1010-R	DFN1010-6	Tape Reel

<p>U74AUP1G00G-AE5-R</p> <p>(1) Packing Type (2) Package Type (3) Green Package</p>	<p>(1) R: Tape Reel (2) AE5: SOT-23-5, AL5: SOT-353, K06-1010: DFN1010-6 (3) G: Halogen Free and Lead Free</p>
---	--

MARKING

SOT-23-5 / SOT-353	DFN1010-6
<p>P00</p>	<p>P0</p>



■ PIN CONFIGURATION

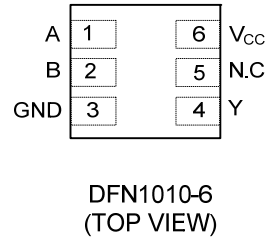
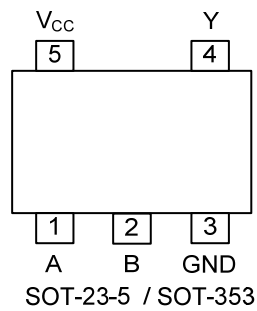

■ FUNCTION TABLE

INPUT(A)	INPUT(B)	OUTPUT(Y)
L	L	H
L	H	H
H	L	H
H	H	L

Note: H: HIGH voltage level; L: LOW voltage level.

■ LOGIC DIAGRAM (positive logic)

For SOT-23-5/SOT-353

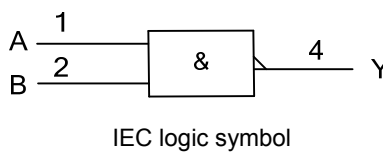
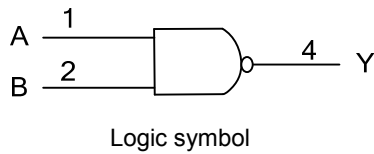

For DFN1010-6

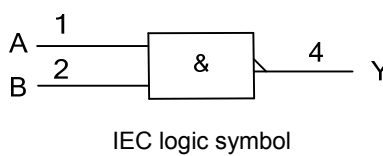
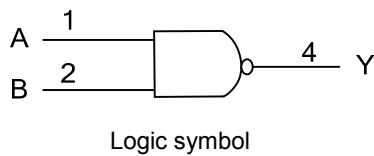

■ ABSOLUTE MAXIMUM RATING

PARAMETER	SYMBOL	CONDITIONS	RATINGS	UNIT
Supply Voltage	V_{CC}		-0.5 ~ +4.6	V
Input Voltage	V_{IN}		-0.5 ~ +4.6	V
Output Voltage	V_{OUT}	Output in the high or low state	-0.5 ~ $V_{CC} + 0.5$	V
		Output in the power-off state	-0.5 ~ +4.6	V
Continuous V_{CC} or GND Current	I_{CC}		±50	mA
Continuous Output Current	I_{OUT}	$V_{OUT}=0 \sim V_{CC}$	±20	mA
Input Clamp Current	I_{IK}	$V_{IN} < 0$	-50	mA
Output Clamp Current	I_{OK}	$V_O > V_{CC}$ or $V_{OUT} < 0$	-50	mA
Storage Temperature Range	T_{STG}		-65 ~ +150	°C

Note: Absolute maximum ratings are those values beyond which the device could be permanently damaged. Absolute maximum ratings are stress ratings only and functional device operation is not implied.

■ RECOMMENDED OPERATING CONDITIONS

PARAMETER	SYMBOL	TEST CONDITIONS	MIN	TYP	MAX	UNIT
Supply Voltage	V_{CC}	Operating	0.8		3.6	V
Input Voltage	V_{IN}		0		3.6	V
Output Voltage	V_{OUT}	High or low state	0		V_{CC}	V
Operating Temperature	T_A		-40		85	°C
Input Transition Rise or Fall Rate	$\Delta t/\Delta v$	$V_{CC}=0.8V \sim 3.6V$			200	ns/V

■ ELECTRICAL CHARACTERISTICS ($T_A = 25^\circ\text{C}$, unless otherwise specified)

PARAMETER	SYMBOL	TEST CONDITIONS	MIN	TYP	MAX	UNIT	
High-level Input Voltage	V_{IH}	$V_{CC}=0.8V$	V_{CC}			V	
		$V_{CC}=1.1V \sim 1.95V$	$0.65 \times V_{CC}$			V	
		$V_{CC}=2.3V \sim 2.7V$	1.6			V	
		$V_{CC}=3V \sim 3.6V$	2			V	
Low-level Input Voltage	V_{IL}	$V_{CC}=0.8V$			0	V	
		$V_{CC}=1.1V \sim 1.95V$			$0.35 \times V_{CC}$	V	
		$V_{CC}=2.3V \sim 2.7V$			0.7	V	
		$V_{CC}=3V \sim 3.6V$			0.9	V	
High-Level Output Voltage	V_{OH}	$V_{CC}=0.8 \sim 3.6V, I_{OH}=-20\mu A$	$V_{CC}-0.1$			V	
		$V_{CC}=1.1V, I_{OH}=-1.1mA$	$0.75 \times V_{CC}$			V	
		$V_{CC}=1.4V, I_{OH}=-1.7mA$	1.11			V	
		$V_{CC}=1.65V, I_{OH}=-1.9mA$	1.32			V	
		$V_{CC}=2.3V$	$I_{OH}=-2.3mA$	2.05			V
			$I_{OH}=-3.1mA$	1.9			V
		$V_{CC}=3V$	$I_{OH}=-2.7mA$	2.72			V
	$I_{OH}=-4mA$	2.6			V		
Low-Level Output Voltage	V_{OL}	$V_{CC}=0.8 \sim 3.6V, I_{OL}=-20\mu A$			0.1	V	
		$V_{CC}=1.1V, I_{OL}=-1.1mA$			$0.3 \times V_{CC}$	V	
		$V_{CC}=1.4V, I_{OL}=-1.7mA$			0.31	V	
		$V_{CC}=1.65V, I_{OL}=-1.9mA$			0.31	V	
		$V_{CC}=2.3V$	$I_{OL}=2.3mA$			0.31	V
			$I_{OL}=3.1mA$			0.44	V
		$V_{CC}=3V$	$I_{OL}=2.7mA$			0.31	V
	$I_{OL}=4mA$			0.44	V		

■ ELECTRICAL CHARACTERISTICS (Cont.)

PARAMETER	SYMBOL	TEST CONDITIONS	MIN	TYP	MAX	UNIT
Input Leakage Current	$I_{I(LEAK)}$	$V_{CC}=0 \sim 3.6V, V_{IN}=GND \sim 3.6V$			± 0.1	μA
Power OFF Leakage Current	I_{off}	$V_{CC}=0V, V_{IN}$ or $V_{OUT}=0 \sim 3.6V$			± 0.2	μA
Additional Power OFF Leakage Current	ΔI_{off}	$V_{CC}=0V \sim 0.2V, V_{IN}$ or $V_{OUT}=0 \sim 3.6V$			± 0.2	μA
Quiescent Supply Current	I_{CC}	$V_{CC}=0.8 \sim 3.6V, V_{IN}=V_{CC}$ or $GND, I_{OUT}=0$			0.5	μA
Additional Quiescent Supply Current Per Input Pin	ΔI_{CC}	$V_{CC}=3.3V, V_{IN}=V_{CC}-0.6V, I_{OUT}=0$			40	μA
Input Capacitance	C_i	$V_{CC}=0V, V_{IN}=V_{CC}$ or GND		1.5		pF
		$V_{CC}=3.6V, V_{IN}=V_{CC}$ or GND		1.5		pF
Output Capacitance	C_{OUT}	$V_{CC}=0V, V_{OUT}=GND$		3		pF

■ SWITCHING CHARACTERISTICS ($T_A = 25^\circ C$, unless otherwise specified)

PARAMETER	SYMBOL	TEST CONDITIONS	MIN	TYP	MAX	UNIT	
Propagation delay from input (A or B) to output(Y)	t_{PLH} / t_{PHL}	$C_L=5pF, R_L=1M\Omega$	$V_{CC}=0.8V$		16.6		ns
			$V_{CC}=1.2\pm 0.1V$	2.6	7		ns
			$V_{CC}=1.5\pm 0.1V$	2.9	5		ns
			$V_{CC}=1.8\pm 0.15V$	2	4		ns
			$V_{CC}=2.5\pm 0.2V$	1.3	2.9		ns
		$C_L=10pF, R_L=1M\Omega$	$V_{CC}=3.3\pm 0.3V$	1	2.4		ns
			$V_{CC}=0.8V$		18.9		ns
			$V_{CC}=1.2\pm 0.1V$	1.5	8		ns
			$V_{CC}=1.5\pm 0.1V$	2.9	5.8		ns
			$V_{CC}=1.8\pm 0.15V$	2	4.7		ns
		$C_L=15pF, R_L=1M\Omega$	$V_{CC}=2.5\pm 0.2V$	1.3	3.4		ns
			$V_{CC}=3.3\pm 0.3V$	1	2.9		ns
			$V_{CC}=0.8V$		21.3		ns
			$V_{CC}=1.2\pm 0.1V$	3.6	9		ns
			$V_{CC}=1.5\pm 0.1V$	2.9	6.5		ns
		$C_L=30pF, R_L=1M\Omega$	$V_{CC}=1.8\pm 0.15V$	2	5.3		ns
			$V_{CC}=2.5\pm 0.2V$	1.3	3.9		ns
			$V_{CC}=3.3\pm 0.3V$	1	3.3		ns
			$V_{CC}=0.8V$		28.4		ns
			$V_{CC}=1.2\pm 0.1V$	4.9	11.9		ns
		$V_{CC}=1.5\pm 0.1V$	2.9	8.6		ns	
		$V_{CC}=1.8\pm 0.15V$	2	7.1		ns	
		$V_{CC}=2.5\pm 0.2V$	1.3	5.3		ns	
		$V_{CC}=3.3\pm 0.3V$	1	4.5		ns	

■ OPERATING CHARACTERISTICS ($f=10MHz, T_A = 25^\circ C$, unless otherwise specified)

PARAMETER	SYMBOL	TEST CONDITIONS	MIN	TYP	MAX	UNIT
Power Dissipation Capacitance	C_{PD}	$V_{CC}=0.8V$		4		pF
		$V_{CC}=1.2\pm 0.1V$		4		pF
		$V_{CC}=1.5\pm 0.1V$		4		pF
		$V_{CC}=1.8\pm 0.15V$		4		pF
		$V_{CC}=2.5\pm 0.2V$		4		pF
		$V_{CC}=3.3\pm 0.3V$		4		pF

■ TEST CIRCUIT AND WAVEFORMS

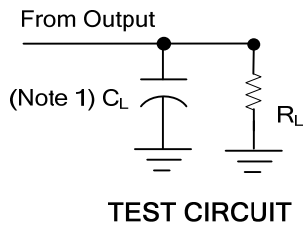

V_{CC}	V_{IN}	t_R / t_F	V_M	C_L	R_L
0.8V	V_{CC}	$\leq 3\text{ns}$	$V_{CC}/2$	5, 10, 15, 30pF	1M Ω
1.2V \pm 0.1V	V_{CC}	$\leq 3\text{ns}$	$V_{CC}/2$	5, 10, 15, 30pF	1M Ω
1.5V \pm 0.1V	V_{CC}	$\leq 3\text{ns}$	$V_{CC}/2$	5, 10, 15, 30pF	1M Ω
1.8V \pm 0.15V	V_{CC}	$\leq 3\text{ns}$	$V_{CC}/2$	5, 10, 15, 30pF	1M Ω
2.5V \pm 0.2V	V_{CC}	$\leq 3\text{ns}$	$V_{CC}/2$	5, 10, 15, 30pF	1M Ω
3.3V \pm 0.3V	V_{CC}	$\leq 3\text{ns}$	$V_{CC}/2$	5, 10, 15, 30pF	1M Ω

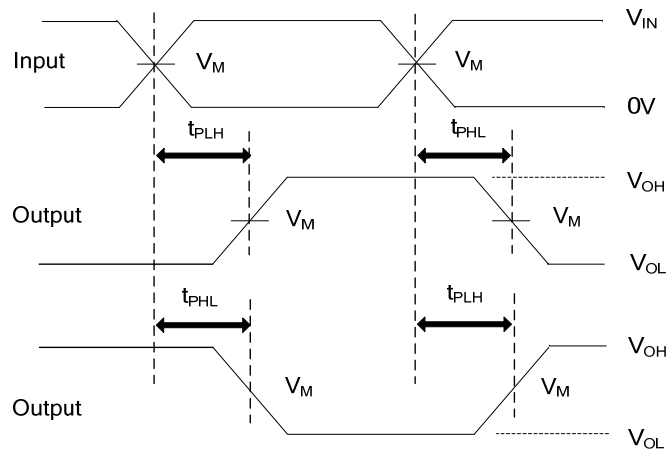

Notes: 1. C_L includes probe and jig capacitance.

2. All input pulses are supplied by generators having the following characteristics: PRR \leq 10MHz, $Z_O = 50\Omega$.

UTC assumes no responsibility for equipment failures that result from using products at values that exceed, even momentarily, rated values (such as maximum ratings, operating condition ranges, or other parameters) listed in products specifications of any and all UTC products described or contained herein. UTC products are not designed for use in life support appliances, devices or systems where malfunction of these products can be reasonably expected to result in personal injury. Reproduction in whole or in part is prohibited without the prior written consent of the copyright owner. UTC reserves the right to make changes to information published in this document, including without limitation specifications and product descriptions, at any time and without notice. This document supersedes and replaces all information supplied prior to the publication hereof.