



## U74AUP1G08

CMOS IC

### 2-INPUT AND GATE

#### DESCRIPTION

The **U74AUP1G08** is a 2-input AND gate which provides the Function  $Y = A \cdot B$  or  $Y = \overline{A + B}$  in positive logic.

This device ensures a very low static and dynamic power consumption across the entire  $V_{CC}$  range from 0.8V to 3.6V.

This device has power-down protective circuit, preventing device destruction when it is powered down.

#### FEATURES

- \* Wide supply voltage range from 0.8V to 3.6V
- \* Inputs accept voltages up to 3.6V
- \*  $I_{OFF}$  supports partial-power-down mode
- \* Low static power consumption;  $I_{CC} = 0.5\mu A$  (Max.)
- \* Optimized for 3.3V Operation

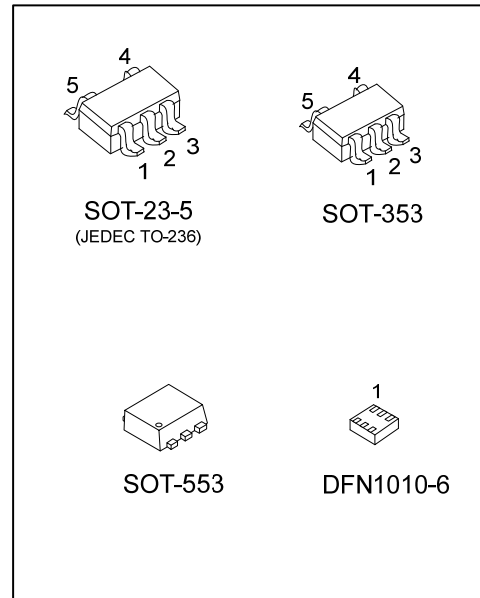

#### ORDERING INFORMATION

Ordering Number		Package	Packing
Lead Free	Halogen Free		
U74AUP1G08L-AE5-R	U74AUP1G08G-AE5-R	SOT-23-5	Tape Reel
U74AUP1G08L-AL5-R	U74AUP1G08G-AL5-R	SOT-353	Tape Reel
U74AUP1G08L-AN5-R	U74AUP1G08G-AN5-R	SOT-553	Tape Reel
U74AUP1G08L-K06-1010-R	U74AUP1G08G-K06-1010-R	DFN1010-6	Tape Reel

<p>U74AUP1G08G-AE5-R</p> <p>(1) Packing Type (2) Package Type (3) Green Package</p>	<p>(1) R: Tape Reel (2) AE5: SOT-23-5, AL5: SOT-353, AN5: SOT-553 K06-1010: DFN1010-6 (3) G: Halogen Free and Lead Free, L: Lead Free</p>
---	---

#### MARKING

SOT-23-5 / SOT-353 / SOT-553	DFN1010-6
<p>P08</p>	<p>P8</p>

■ PIN CONFIGURATION

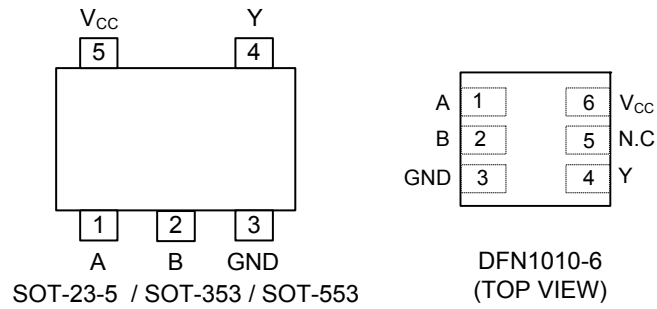

■ FUNCTION TABLE (each gate)

INPUT		OUTPUT
A	B	Y
L	L	L
L	H	L
H	L	L
H	H	H

Note: H: HIGH voltage level; L: LOW voltage level.

■ LOGIC DIAGRAM (positive logic)

For SOT-23-5/SOT-353/SOT-553

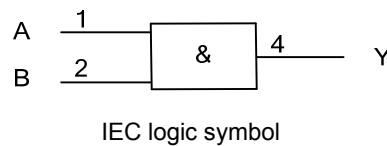
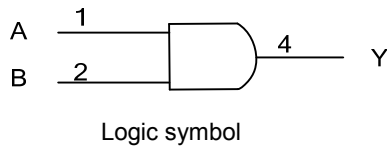

For DFN1010-6

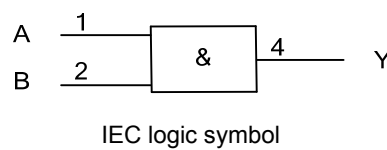
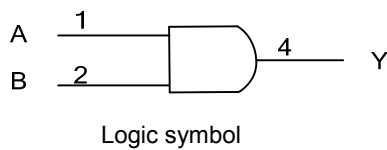

FLYING 汎翔國際有限公司  
[www.flying1688.com](http://www.flying1688.com)

### ■ ABSOLUTE MAXIMUM RATING

PARAMETER	SYMBOL	CONDITIONS	RATINGS	UNIT
Supply Voltage	$V_{CC}$		-0.5 ~+4.6	V
Input Voltage	$V_{IN}$		-0.5 ~+4.6	V
Output Voltage	$V_{OUT}$	Output in the high or low state	-0.5 ~ $V_{CC} + 0.5$	V
		Output in the power-off state	-0.5 ~ +4.6	V
Continuous $V_{CC}$ or GND Current	$I_{CC}$		±50	mA
Continuous Output Current	$I_{OUT}$	$V_{OUT}=0 \sim V_{CC}$	±20	mA
Input Clamp Current	$I_{IK}$	$V_{IN}<0$	-50	mA
Output Clamp Current	$I_{OK}$	$V_O>V_{CC}$ or $V_{OUT}<0$	-50	mA
Storage Temperature Range	$T_{STG}$		-65 ~+150	°C

Note: Absolute maximum ratings are those values beyond which the device could be permanently damaged. Absolute maximum ratings are stress ratings only and functional device operation is not implied.

### ■ RECOMMENDED OPERATING CONDITIONS

PARAMETER	SYMBOL	TEST CONDITIONS	MIN	TYP	MAX	UNIT
Supply Voltage	$V_{CC}$	Operating	0.8		3.6	V
Input Voltage	$V_{IN}$		0		3.6	V
Output Voltage	$V_{OUT}$	High or low state	0		$V_{CC}$	V
Operating Temperature	$T_A$		-40		85	°C
Input Transition Rise or Fall Rate	$\Delta t/\Delta v$	$V_{CC}=0.8V \sim 3.6V$			200	ns/V

### ■ ELECTRICAL CHARACTERISTICS ( $T_A = 25^\circ\text{C}$ , unless otherwise specified)

PARAMETER	SYMBOL	TEST CONDITIONS	MIN	TYP	MAX	UNIT	
High-level Input Voltage	$V_{IH}$	$V_{CC}=0.8V$	$V_{CC}$			V	
		$V_{CC}=1.1V \sim 1.95V$	$0.65 \times V_{CC}$			V	
		$V_{CC}=2.3V \sim 2.7V$	1.6			V	
		$V_{CC}=3V \sim 3.6V$	2			V	
Low-level Input Voltage	$V_{IL}$	$V_{CC}=0.8V$			0	V	
		$V_{CC}=1.1V \sim 1.95V$			$0.35 \times V_{CC}$	V	
		$V_{CC}=2.3V \sim 2.7V$			0.7	V	
		$V_{CC}=3V \sim 3.6V$			0.9	V	
High-Level Output voltage	$V_{OH}$	$V_{CC}=0.8 \sim 3.6V, I_{OH}=-20\mu A$	$V_{CC}-0.1$			V	
		$V_{CC}=1.1V, I_{OH}=-1.1mA$	$0.75 \times V_{CC}$			V	
		$V_{CC}=1.4V, I_{OH}=-1.7mA$	1.11			V	
		$V_{CC}=1.65V, I_{OH}=-1.9mA$	1.32			V	
		$V_{CC}=2.3V$	$I_{OH}=-2.3mA$	2.05			V
			$I_{OH}=-3.1mA$	1.9			V
		$V_{CC}=3V$	$I_{OH}=-2.7mA$	2.72			V
			$I_{OH}=-4mA$	2.6			V
Low-Level Output voltage	$V_{OL}$	$V_{CC}=0.8 \sim 3.6V, I_{OL}=20\mu A$			0.1	V	
		$V_{CC}=1.1V, I_{OL}=1.1mA$			$0.3 \times V_{CC}$	V	
		$V_{CC}=1.4V, I_{OL}=1.7mA$			0.31	V	
		$V_{CC}=1.65V, I_{OL}=1.9mA$			0.31	V	
		$V_{CC}=2.3V$	$I_{OL}=2.3mA$			0.31	V
			$I_{OL}=3.1mA$			0.44	V
		$V_{CC}=3V$	$I_{OL}=2.7mA$			0.31	V
			$I_{OL}=4mA$			0.44	V

## ■ ELECTRICAL CHARACTERISTICS (Cont.)

PARAMETER	SYMBOL	TEST CONDITIONS	MIN	TYP	MAX	UNIT
Input Leakage Current	$I_{I(LEAK)}$	$V_{CC}=0 \sim 3.6V, V_{IN}=GND \sim 3.6V$			$\pm 0.1$	$\mu A$
Power OFF Leakage Current	$I_{off}$	$V_{CC}=0V, V_{IN}$ or $V_{OUT}=0 \sim 3.6V$			$\pm 0.2$	$\mu A$
Additional Power OFF Leakage Current	$\Delta I_{off}$	$V_{CC}=0V \sim 0.2V, V_{IN}$ or $V_{OUT}=0 \sim 3.6V$			$\pm 0.2$	$\mu A$
Quiescent Supply Current	$I_{CC}$	$V_{CC}=0.8 \sim 3.6V, V_{IN}=V_{CC}$ or $GND, I_{OUT}=0$			0.5	$\mu A$
Additional Quiescent Supply Current Per Input Pin	$\Delta I_{CC}$	$V_{CC}=3.3V, V_{IN}=V_{CC}-0.6V, I_{OUT}=0$			40	$\mu A$
Input Capacitance	$C_i$	$V_{CC}=0V, V_{IN}=V_{CC}$ or $GND$		1.5		pF
		$V_{CC}=3.6V, V_{IN}=V_{CC}$ or $GND$		1.5		pF
Output Capacitance	$C_{OUT}$	$V_{CC}=0V, V_{OUT}=GND$		3		pF

## ■ SWITCHING CHARACTERISTICS ( $T_A=25^\circ C$ , unless otherwise specified)

PARAMETER	SYMBOL	TEST CONDITIONS	MIN	TYP	MAX	UNIT		
Propagation delay from inputs (A or B) to output(Y)	$t_{PD}$	$C_L=5pF, R_L=1M\Omega$	$V_{CC}=0.8V$		18		ns	
			$V_{CC}=1.2\pm 0.1V$	2.6	7.3		ns	
			$V_{CC}=1.5\pm 0.1V$	1.4	5.2		ns	
			$V_{CC}=1.8\pm 0.15V$	1	4.2		ns	
			$V_{CC}=2.5\pm 0.2V$	1	3		ns	
		$C_L=10pF, R_L=1M\Omega$	$V_{CC}=0.8V$			21		ns
			$V_{CC}=1.2\pm 0.1V$	1.5	8.5		ns	
			$V_{CC}=1.5\pm 0.1V$	1	6.2		ns	
			$V_{CC}=1.8\pm 0.15V$	1	5		ns	
			$V_{CC}=2.5\pm 0.2V$	1	3.6		ns	
		$C_L=15pF, R_L=1M\Omega$	$V_{CC}=0.8V$			24		ns
			$V_{CC}=1.2\pm 0.1V$	3.6	9.9		ns	
			$V_{CC}=1.5\pm 0.1V$	2.3	7.2		ns	
			$V_{CC}=1.8\pm 0.15V$	1.6	5.8		ns	
			$V_{CC}=2.5\pm 0.2V$	1	4.3		ns	
		$C_L=30pF, R_L=1M\Omega$	$V_{CC}=0.8V$			32.8		ns
			$V_{CC}=1.2\pm 0.1V$	4.9	13.1		ns	
			$V_{CC}=1.5\pm 0.1V$	3.4	9.5		ns	
			$V_{CC}=1.8\pm 0.15V$	2.5	7.7		ns	
			$V_{CC}=2.5\pm 0.2V$	1.8	5.7		ns	
		$V_{CC}=3.3\pm 0.3V$	1.5	4.7		ns		

## ■ OPERATING CHARACTERISTICS ( $f=10MHz, T_A=25^\circ C$ , unless otherwise specified)

PARAMETER	SYMBOL	TEST CONDITIONS	MIN	TYP	MAX	UNIT
Power Dissipation Capacitance	$C_{PD}$	$V_{CC}=0.8V$		4		pF
		$V_{CC}=1.2\pm 0.1V$		4		pF
		$V_{CC}=1.5\pm 0.1V$		4		pF
		$V_{CC}=1.8\pm 0.15V$		4		pF
		$V_{CC}=2.5\pm 0.2V$		4.1		pF
		$V_{CC}=3.3\pm 0.3V$		4.3		pF

## ■ TEST CIRCUIT AND WAVEFORMS

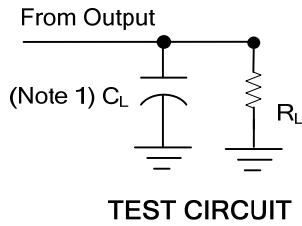

$V_{CC}$	$V_{IN}$	$t_R / t_F$	$V_M$	$C_L$	$R_L$
0.8V	$V_{CC}$	$\leq 3ns$	$V_{CC}/2$	5,10,15,30pF	1M $\Omega$
1.2V $\pm$ 0.1V	$V_{CC}$	$\leq 3ns$	$V_{CC}/2$	5,10,15,30pF	1M $\Omega$
1.5V $\pm$ 0.1V	$V_{CC}$	$\leq 3ns$	$V_{CC}/2$	5,10,15,30pF	1M $\Omega$
1.8V $\pm$ 0.15V	$V_{CC}$	$\leq 3ns$	$V_{CC}/2$	5,10,15,30pF	1M $\Omega$
2.5V $\pm$ 0.2V	$V_{CC}$	$\leq 3ns$	$V_{CC}/2$	5,10,15,30pF	1M $\Omega$
3.3V $\pm$ 0.3V	$V_{CC}$	$\leq 3ns$	$V_{CC}/2$	5,10,15,30pF	1M $\Omega$

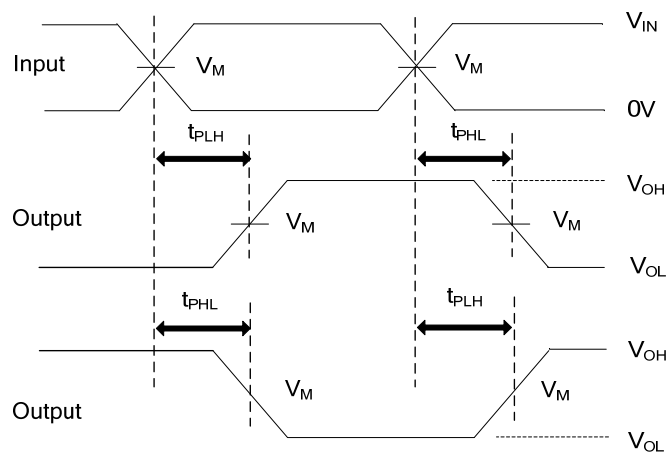

Notes: 1.  $C_L$  includes probe and jig capacitance.

2. All input pulses are supplied by generators having the following characteristics: PRR  $\leq$  10MHz,  $Z_0 = 50\Omega$ .

UTC assumes no responsibility for equipment failures that result from using products at values that exceed, even momentarily, rated values (such as maximum ratings, operating condition ranges, or other parameters) listed in products specifications of any and all UTC products described or contained herein. UTC products are not designed for use in life support appliances, devices or systems where malfunction of these products can be reasonably expected to result in personal injury. Reproduction in whole or in part is prohibited without the prior written consent of the copyright owner. UTC reserves the right to make changes to information published in this document, including without limitation specifications and product descriptions, at any time and without notice. This document supersedes and replaces all information supplied prior to the publication hereof.