



U74CBT3253

CMOS IC

DUAL 1-OF-4 FET MULTIPLEXER/DEMULTIPLEXER

DESCRIPTION

The **U74CBT3253** is a dual 1-of-4 high-speed TTL-compatible FET multiplexer/demultiplexer. The low on-state resistance of the switch allows connections to be made with minimal propagation delay.

$\overline{1OE}$, $\overline{2OE}$, S0, and S1 select the appropriate B output for the A-input data.

FEATURES

- * V_{CC} Operating Range From 4V to 5.5V
- * Bidirectional Data Flow, With minimal Propagation Delay
- * Low ON-State Resistance (R_{ON}) Characteristics ($R_{ON} = 5\Omega$ Typ.)
- * Low Power Consumption $I_{CC} = 3\mu A$ (Max)

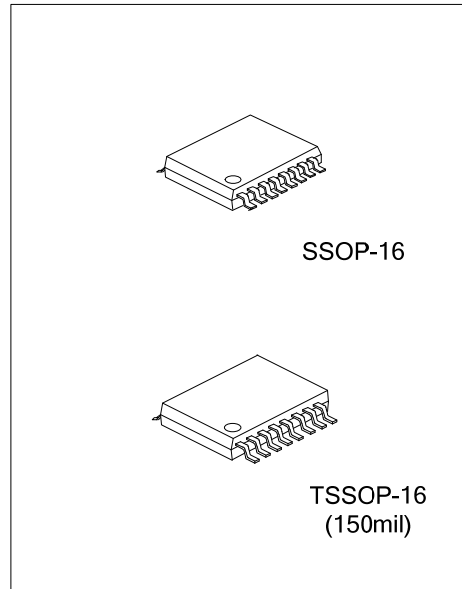

ORDERING INFORMATION

Ordering Number		Package	Packing
Lead Free	Halogen Free		
U74CBT3253L-R16-R	U74CBT3253G-R16-R	SSOP-16	Tape Reel
U74CBT3253L-P16-R	U74CBT3253G-P16-R	TSSOP-16	Tape Reel

<p>U74CBT3253G-R16-R</p> <p>(1) Packing Type</p> <p>(2) Package Type</p> <p>(3) Green Package</p>	<p>(1) R: Tape Reel</p> <p>(2) R16: SSOP-16, P16: TSSOP-16</p> <p>(3) G: Halogen Free and Lead Free, L: Lead Free</p>
---	---

MARKING

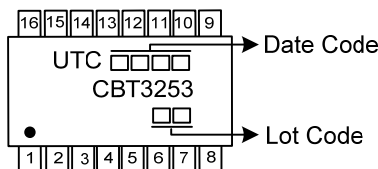

■ PIN CONFIGURATION

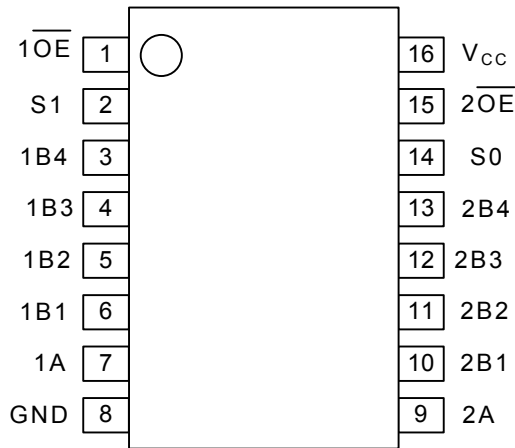

■ FUNCTION TABLE

INPUTS			INPUT/OUTPUT A	FUNCTION
\overline{OE}	S1	S0		
L	L	L	B1	A port=B1 port
L	L	H	B2	A port=B2 port
L	H	L	B3	A port=B3 port
L	H	H	B4	A port=B4 port
H	X	X	Z	Disconnect

■ LOGIC DIAGRAM

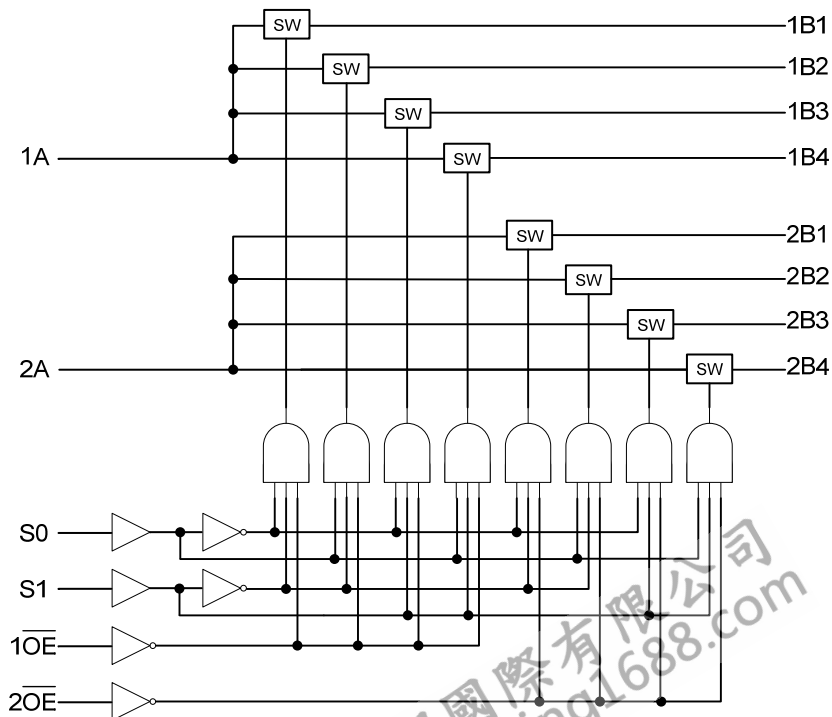

■ ABSOLUTE MAXIMUM RATING (T_A=25°C, unless otherwise specified)

PARAMETER	SYMBOL	RATINGS	UNIT
Supply Voltage	V _{CC}	-0.5 ~ 7	V
DC Input Voltage(see Note 2,3)	V _{IN}	-0.5 ~ 7	V
DC Switch Voltage(see Note 2,3)	V _{IN(SW)}	-0.5 ~7	V
	V _{OUT(SW)}		
Control Input Clamp Current	I _{IK}	-50	mA
DC V _{CC} or GND Current	I _{CC}	±100	mA
ON-State Switch Current	I _{IN(SW)}	±128	mA
	I _{OUT(SW)}		
Storage Temperature	T _{STG}	-65~+150	°C

Notes: 1. Absolute maximum ratings are those values beyond which the device could be permanently damaged.

Absolute maximum ratings are stress ratings only and functional device operation is not implied.

2. All voltages are with respect to ground.

3. The input and output voltage ratings may be exceeded if the input and output clamp-current ratings are observed.

■ THERMAL DATA

PARAMETER	SYMBOL	RATINGS	UNIT
Junction to Ambient	θ _{JA}	90	°C/W
		110	°C/W

■ RECOMMENDED OPERATING CONDITIONS

PARAMETER	SYMBOL	MIN	TYP	MAX	UNIT
Supply Voltage	V _{CC}	4		5.5	V
High-Level Control Input Voltage	V _{IH}	2			V
Low-Level Control Input Voltage	V _{IL}			0.8	V
Data Input Voltage	V _{IN}	0		5.5	V
Operating Temperature	T _A	-40		85	°C

■ ELECTRICAL CHARACTERISTICS (T_a=25°C, unless otherwise specified)

PARAMETER	SYMBOL	TEST CONDITIONS	MIN	TYP	MAX	UNIT
Control Input Clamp Voltage	V _{IK}	V _{CC} = 4.5V, I _{IN} = -18mA			-1.2	V
Input Leakage Current	I _{I(LEAK)}	V _{CC} = 5.5V, V _{IN} = V _{CC} or GND			±1	µA
Quiescent Supply Current	I _{CC}	V _{CC} = 5.5V, I _{IN} / I _{OUT} = 0 V _{IN} = V _{CC} or GND, Switch ON or OFF			3	µA
Additional Quiescent Supply Current	ΔI _{CC}	V _{CC} = 5.5V, One input at 3.4V, Other inputs at V _{CC} or GND			2.5	mA
Control Input Capacitance	C _{IN}	V _{IN} = 3V or 0, V _{CC} = 5V		3.5		pF
A Port Input Capacitance	C _{IO(OFF)}	V _{IN} / V _{OUT} = 3V or 0, V _{CC} = 5V V _{IN} = V _{CC} or GND, Switch OFF		10		pF
B Port Input Capacitance				4		pF
ON-Resistance	R _{ON}	V _{CC} = 4.5V, V _{IN} = 0	I _{OUT} = 64mA	5	7	Ω
			I _{OUT} = 30mA	5	7	Ω
		V _{CC} = 4.5V, V _{IN} = 2.4V	I _{OUT} = -15mA	10	15	Ω

■ SWITCHING CHARACTERISTICS ($C_L=50\text{pF}$, $R_L=500\Omega$, see TEST CIRCUIT AND WAVEFORMS)

PARAMETER	SYMBOL	TEST CONDITIONS	MIN	TYP	MAX	UNIT
From input (A or B) to output (B or A) (Note)	t_{pd}	$V_{CC}=4V$			0.35	ns
		$V_{CC}=5V\pm 0.5V$			0.25	ns
From input S to output A	$t_{pd(s)}$	$V_{CC}=4V$			6.6	ns
		$V_{CC}=5V\pm 0.5V$		1.6	6.2	ns
From input S to output B	t_{en}	$V_{CC}=4V$			7.1	ns
		$V_{CC}=5V\pm 0.5V$		1.3	6.3	ns
From input \overline{OE} to output (A or B)	t_{en}	$V_{CC}=4V$			7.3	ns
		$V_{CC}=5V\pm 0.5V$		1.4	6.4	ns
From input S to output B	t_{dis}	$V_{CC}=4V$			7.9	ns
		$V_{CC}=5V\pm 0.5V$		1.1	7.4	ns
From input \overline{OE} to output (A or B)	t_{dis}	$V_{CC}=4V$			7.3	ns
		$V_{CC}=5V\pm 0.5V$		2.3	7.0	ns

Note: The propagation delay is the calculated RC time constant of the typical ON-state resistance of the switch and the specified load capacitance, when driven by an ideal voltage source (zero output impedance).

TEST CIRCUIT AND WAVEFORMS

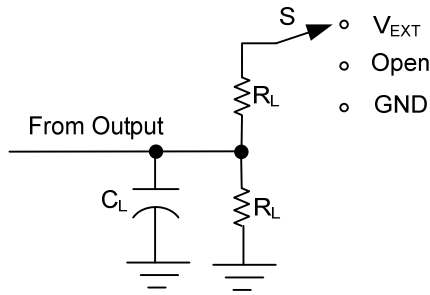

TEST	S
t_{PLH}/t_{PHL}	Open
t_{PHZ}/t_{PZH}	Open
t_{PLZ}/t_{PZL}	V_{EXT}

TEST	V_{CC}	V_I	t_R / t_F	V_{Δ}	V_{EXT}	C_L	R_L
t_{PLH}/t_{PHL}	4V	V_{CC} or GND	≤ 2.5 ns		Open	50pF	500 Ω
	5V \pm 0.5V	V_{CC} or GND	≤ 2.5 ns		Open	50pF	500 Ω
t_{PLZ}/t_{PZL}	4V	GND	≤ 2.5 ns	0.3V	7V	50pF	500 Ω
	5V \pm 0.5V	GND	≤ 2.5 ns	0.3V	7V	50pF	500 Ω
t_{PHZ}/t_{PZH}	4V	V_{CC}	≤ 2.5 ns	0.3V	Open	50pF	500 Ω
	5V \pm 0.5V	V_{CC}	≤ 2.5 ns	0.3V	Open	50pF	500 Ω

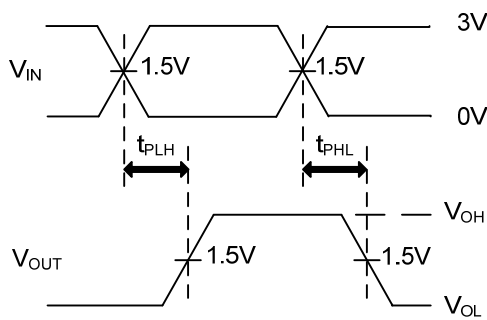

PROPAGATION DELAY TIMES

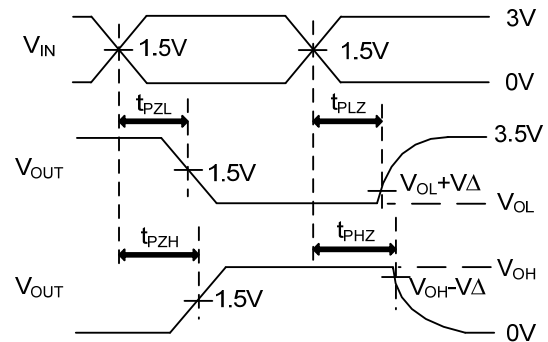

ENABLE AND DISABLE TIMES

- Notes:
- C_L includes probe and jig capacitance.
 - All input pulses are supplied by generators having the following characteristics: $PRR \leq 10$ MHz, $Z_O = 50\Omega$, $t_r \leq 2.5$ ns, $t_f \leq 2.5$ ns.
 - The outputs are measured one at a time with one transition per measurement.
 - t_{PLZ} and t_{PHZ} are the same as t_{dis} .
 - t_{PZL} and t_{PZH} are the same as t_{en} .
 - t_{PLH} and t_{PHL} are the same as $t_{pd}(s)$.
 - All parameters and waveforms are not applicable to all devices.

UTC assumes no responsibility for equipment failures that result from using products at values that exceed, even momentarily, rated values (such as maximum ratings, operating condition ranges, or other parameters) listed in products specifications of any and all UTC products described or contained herein. UTC products are not designed for use in life support appliances, devices or systems where malfunction of these products can be reasonably expected to result in personal injury. Reproduction in whole or in part is prohibited without the prior written consent of the copyright owner. UTC reserves the right to make changes to information published in this document, including without limitation specifications and product descriptions, at any time and without notice. This document supersedes and replaces all information supplied prior to the publication hereof.