



U74HC165

CMOS IC

8-BIT PARALLEL-LOAD SHIFT REGISTER

DESCRIPTION

The **U74HC165** is an 8-bit parallel-load shift register that, when clocked, shifts the data toward a serial (Q_H) output. Parallel-in access to each stage is provided by eight individual direct data (A-H) inputs that are enabled by a low level at shift/load (SH/\overline{LD}) input. The U74HC165 also features a clock-inhibit ($CLK\ INH$) function and a complementary serial (\overline{Q}_H) output.

Clocking is accomplished by a low-to-high transition of the clock (CLK) input while SH/\overline{LD} is held high and $CLK\ INH$ is held low. The functions of CLK and $CLK\ INH$ are interchangeable. Since a low CLK and a low-to-high transition of $CLK\ INH$ also accomplish clocking, $CLK\ INH$ should be changed to the high level only while CLK is high. Parallel loading is inhibited when SH/\overline{LD} is held high. While SH/\overline{LD} is low, the parallel inputs to the register are enabled independently of the levels of the CLK , $CLK\ INH$, or serial (SER) inputs.

FEATURES

- * Complementary Outputs
- * Direct Overriding Load (Data) Inputs
- * Gated Clock Inputs
- * Parallel-to-Serial Data Conversion

ORDERING INFORMATION

Ordering Number		Package	Packing
Lead Free	Halogen Free		
U74HC165G-S16-R	U74HC165G-S16-R	SOP-16	Tape Reel
U74HC165G-P16-R	U74HC165G-P16-R	TSSOP-16	Tape Reel

<p>U74HC165G-S16-R</p> <ul style="list-style-type: none"> (1) Packing Type (2) Package Type (3) Green Package 	<ul style="list-style-type: none"> (1) R: Tape Reel (2) S16: SOP-16, P16: TSSOP-16 (3) G: Halogen Free and Lead Free, L: Lead Free
--	---

MARKING

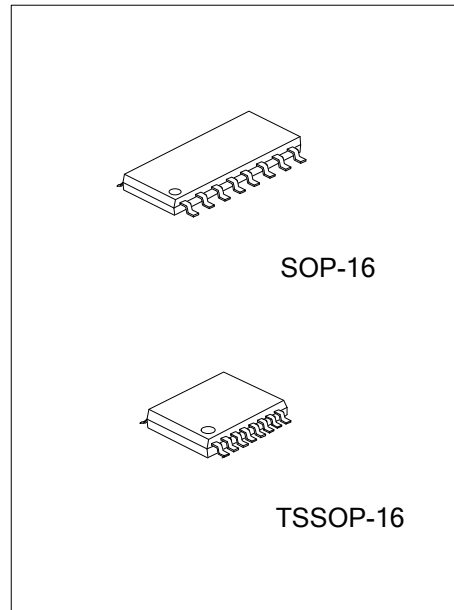
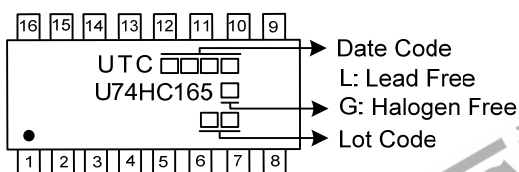

■ PIN CONFIGURATION

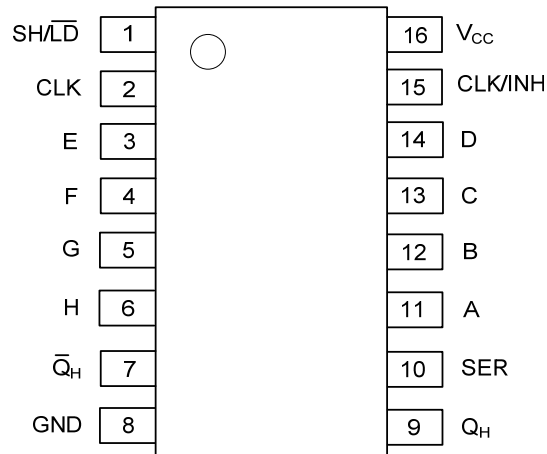

■ FUNCTION TABLE

INPUTS			FUNCTION
SH/LD	CLK	CLK INH	
L	X	X	Parallel load
H	H	X	No change
H	X	H	No change
H	L	↑	Shift↑
H	↑	L	Shift↑

↑ Shift=content of each internal register shifts toward serial output Q_H. Data at SER is shifted into the first register.

■ LOGIC SYMBOL

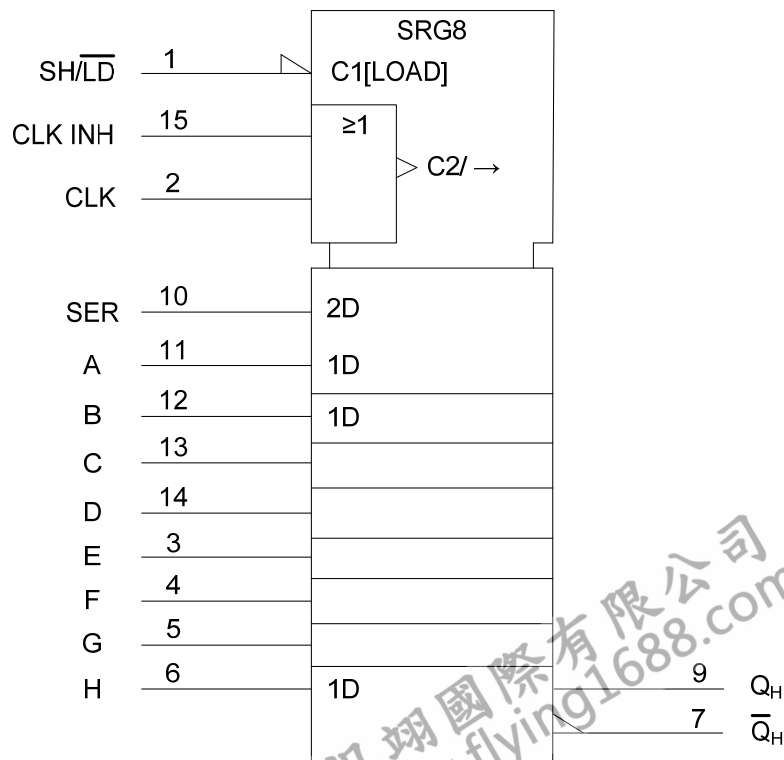

■ LOGIC DIAGRAM (positive logic)

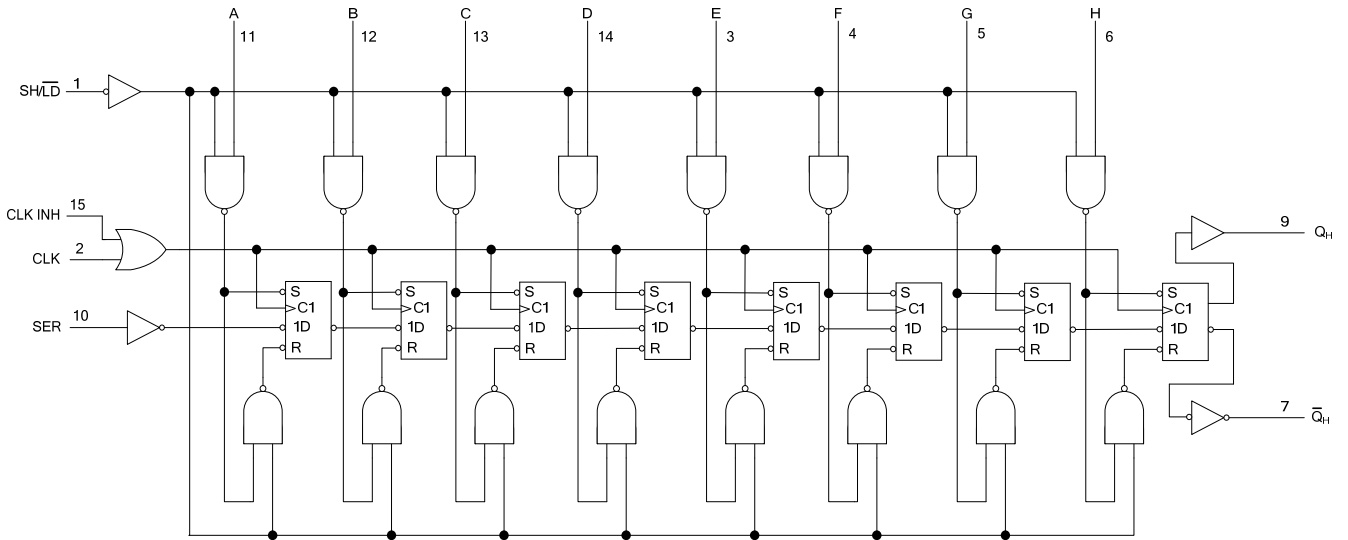

■ TYPICAL SHIFT, LOAD, AND INHIBIT SEQUENCE

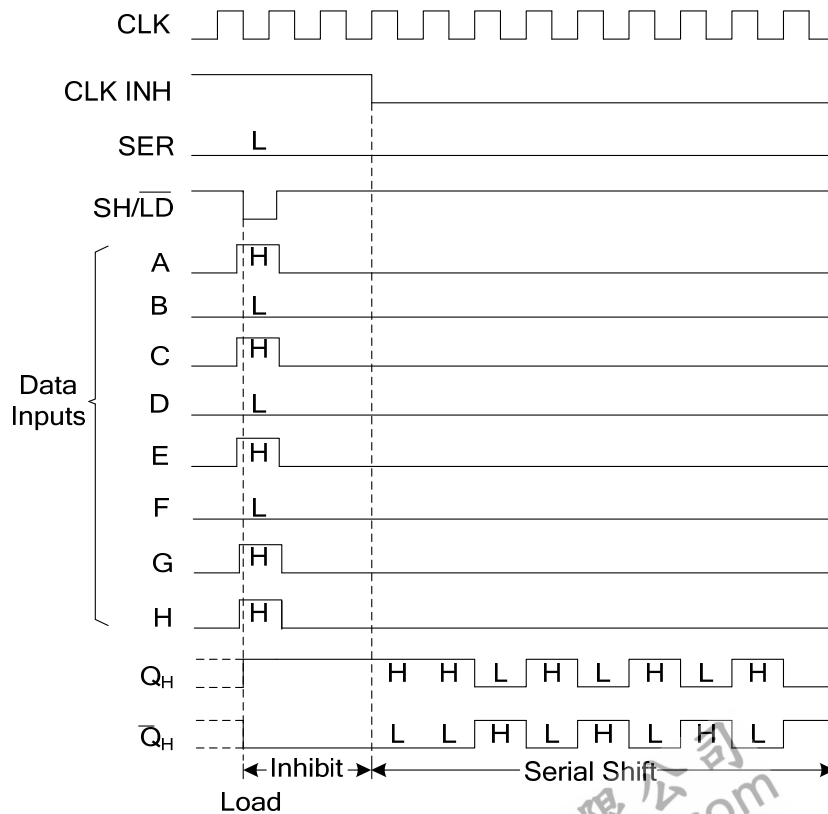

■ ABSOLUTE MAXIMUM RATING

PARAMETER	SYMBOL	RATINGS	UNIT
Supply Voltage	V_{CC}	-0.5 ~ 7	V
V_{CC} or GND Current	I_{CC}	±50	mA
Output Current	I_{OUT}	±25	mA
Input Clamp Current	I_{IK}	±20	mA
Output Clamp Current	I_{OK}	±20	mA
Storage Temperature	T_{STG}	-65 ~ + 150	°C

Note: Absolute maximum ratings are those values beyond which the device could be permanently damaged.
 Absolute maximum ratings are stress ratings only and functional device operation is not implied.

■ THERMAL RESISTANCES

PARAMETER	SYMBOL	RATINGS	UNIT
Junction to Ambient	SOP-16	73	°C/W
	TSSOP-16	110	

■ RECOMMENDED OPERATING CONDITIONS

PARAMETER	SYMBOL	TEST CONDITIONS	MIN	TYP	MAX	UNIT
Supply Voltage	V_{CC}		2	5	6	V
High-level Input Voltage	V_{IH}	$V_{CC}=2V$	1.5			V
		$V_{CC}=4.5V$	3.15			
		$V_{CC}=6V$	4.2			
Low-level Input Voltage	V_{IL}	$V_{CC}=2V$			0.5	V
		$V_{CC}=4.5V$			1.35	
		$V_{CC}=6V$			1.8	
Input Voltage	V_{IN}		0		V_{CC}	V
Output Voltage	V_{OUT}		0		V_{CC}	V
Input Transition (Rise and Fall) Time	t_t	$V_{CC}=2V$			1000	ns
		$V_{CC}=4.5V$			500	
		$V_{CC}=6V$			400	
Operating Free-air Temperature	T_A		-40		+125	°C

■ ELECTRICAL CHARACTERISTICS ($T_A = 25^\circ C$, unless otherwise specified)

PARAMETER	SYMBOL	TEST CONDITIONS	MIN	TYP	MAX	UNIT
Output Voltage High-Level	V_{OH}	$V_{CC}=2V, I_{OH}=-20\mu A$	1.9	1.998		V
		$V_{CC}=4.5V, I_{OH}=-20\mu A$	4.4	4.499		
		$V_{CC}=6V, I_{OH}=-20\mu A$	5.9	5.999		
		$V_{CC}=4.5V, I_{OH}=-4mA$	3.98	4.3		
		$V_{CC}=6V, I_{OH}=-5.2mA$	5.48	5.8		
Output Voltage Low-Level	V_{OL}	$V_{CC}=2V, I_{OL}=20\mu A$		0.002	0.1	V
		$V_{CC}=4.5V, I_{OL}=20\mu A$		0.001	0.1	
		$V_{CC}=6V, I_{OL}=20\mu A$		0.001	0.1	
		$V_{CC}=4.5V, I_{OL}=4mA$		0.17	0.26	
		$V_{CC}=6V, I_{OL}=5.2mA$		0.15	0.26	
Input Leakage Current	$I_{I(LEAK)}$	$V_{CC}=6V, V_{IN}=V_{CC}$ or GND		±0.1	±100	nA
Quiescent Supply Current	I_{CC}	$V_{CC}=6V, V_{IN}=V_{CC}$ or GND, $I_{OUT}=0$			8	µA
Input Capacitance	C_i	$V_{CC}=2V$ to 6V		3	10	pF

■ TIMING REQUIREMENTS ($T_A = 25^\circ C$, unless otherwise specified)

PARAMETER	SYMBOL	TEST CONDITIONS	MIN	TYP	MAX	UNIT
Clock frequency	f_{clock}	$V_{CC}=2V$	0		6	MHz
		$V_{CC}=4.5V$	0		31	
		$V_{CC}=6V$	0		36	

■ TIMING REQUIREMENTS(Cont.)

PARAMETER		SYMBOL	TEST CONDITIONS	MIN	TYP	MAX	UNIT
Pulse duration	SH/LD low	t_w	$V_{CC}=2V$	80			ns
			$V_{CC}=4.5V$	16			
			$V_{CC}=6V$	14			
	CLK high or low		$V_{CC}=2V$	80			
			$V_{CC}=4.5V$	16			
			$V_{CC}=6V$	14			
Setup time	SH/LD high before CLK↑	t_{su}	$V_{CC}=2V$	80			ns
			$V_{CC}=4.5V$	16			
			$V_{CC}=6V$	14			
	SER before CLK↑		$V_{CC}=2V$	40			
			$V_{CC}=4.5V$	8			
			$V_{CC}=6V$	7			
	CLK INH low before CLK↑		$V_{CC}=2V$	100			
			$V_{CC}=4.5V$	20			
			$V_{CC}=6V$	17			
	CLK INH high before CLK↑		$V_{CC}=2V$	40			
			$V_{CC}=4.5V$	8			
			$V_{CC}=6V$	7			
Data before SH/LD ↓	$V_{CC}=2V$	100					
	$V_{CC}=4.5V$	20					
	$V_{CC}=6V$	17					
Hold time	SER data after CLK↑	t_h	$V_{CC}=2V$	5			ns
			$V_{CC}=4.5V$	5			
			$V_{CC}=6V$	5			
	PAR data after SH/LD ↓		$V_{CC}=2V$	5			
			$V_{CC}=4.5V$	5			
			$V_{CC}=6V$	5			

■ SWITCHING CHARACTERISTICS ($t_r = t_f = 6ns$, $C_L = 50pF$, $T_A = 25^\circ C$, unless otherwise specified)

PARAMETER	SYMBOL	V_{CC}	MIN	TYP	MAX	UNIT		
Minimum Frequency Response	f_{max}	$V_{CC}=2V$	6	13		ns		
		$V_{CC}=4.5V$	31	50				
		$V_{CC}=6V$	36	62				
Propagation delay from input (SH/LD) to output(QH or \bar{Q}_H)	t_{PD}	$V_{CC}=2V$		80	150	ns		
Propagation delay from input (CLK) to output(QH or \bar{Q}_H)		$V_{CC}=4.5V$		20	30			
		$V_{CC}=6V$		16	26			
		Propagation delay from input (H) to output(QH or \bar{Q}_H)	$V_{CC}=2V$		75		150	
$V_{CC}=4.5V$				15	30			
$V_{CC}=6V$				13	26			
To Output(Any)		t_t	$V_{CC}=2V$		38		75	ns
			$V_{CC}=4.5V$		8		15	
			$V_{CC}=6V$		6		13	

■ OPERATING CHARACTERISTICS ($T_A = 25^\circ C$, unless otherwise specified)

PARAMETER	SYMBOL	TEST CONDITIONS	MIN	TYP	MAX	UNIT
Power Dissipation Capacitance	C_{PD}	No load		75		pF

■ TEST CIRCUIT AND WAVEFORMS

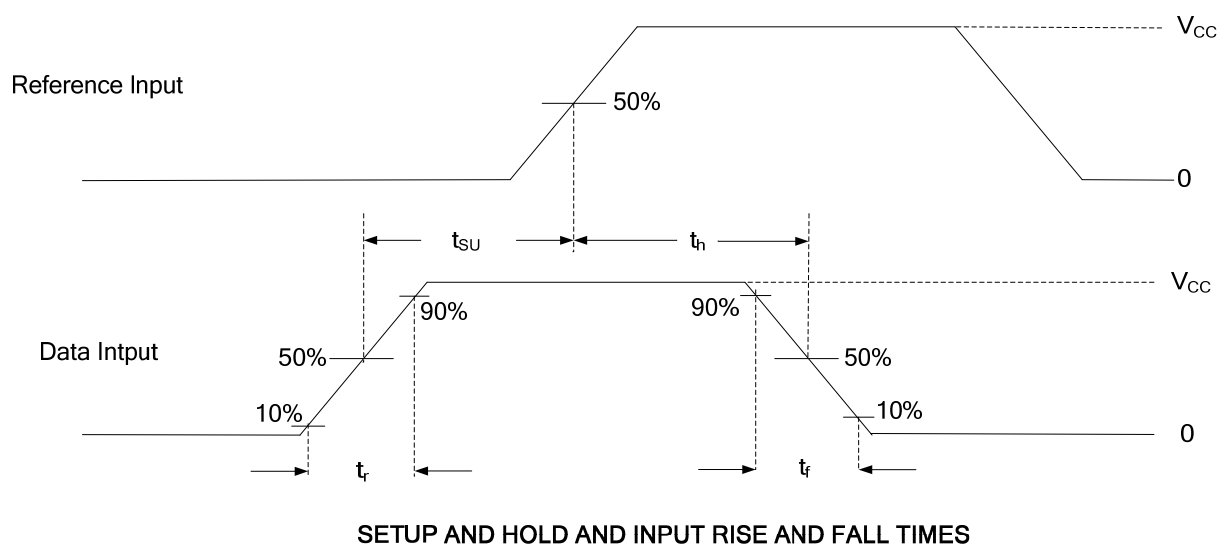
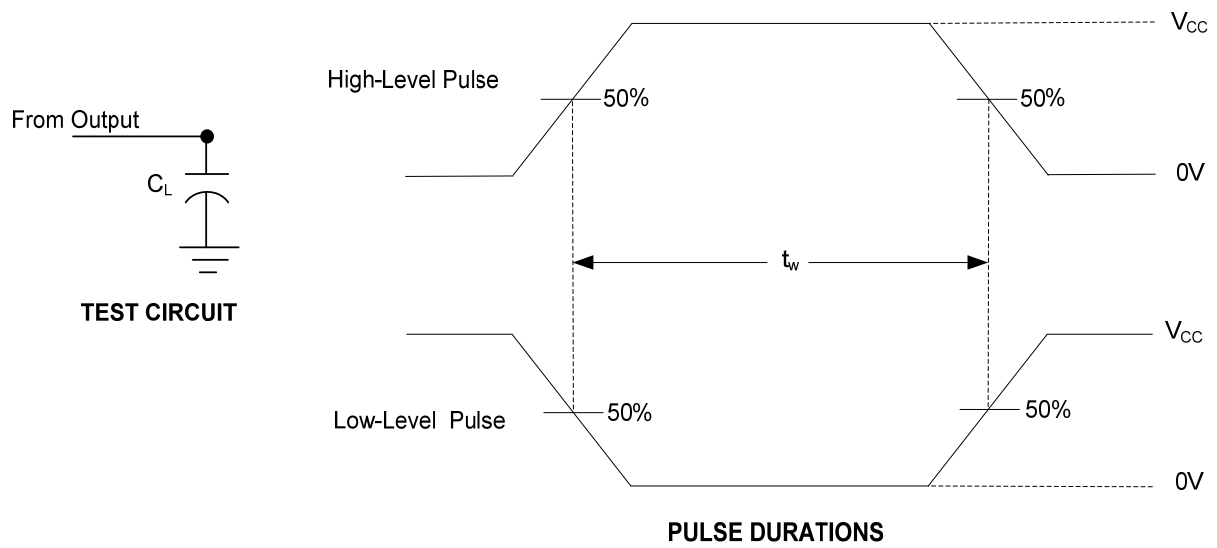

FLYING 汎翔國際有限公司
www.flying1688.com

■ TEST CIRCUIT AND WAVEFORMS(Cont.)

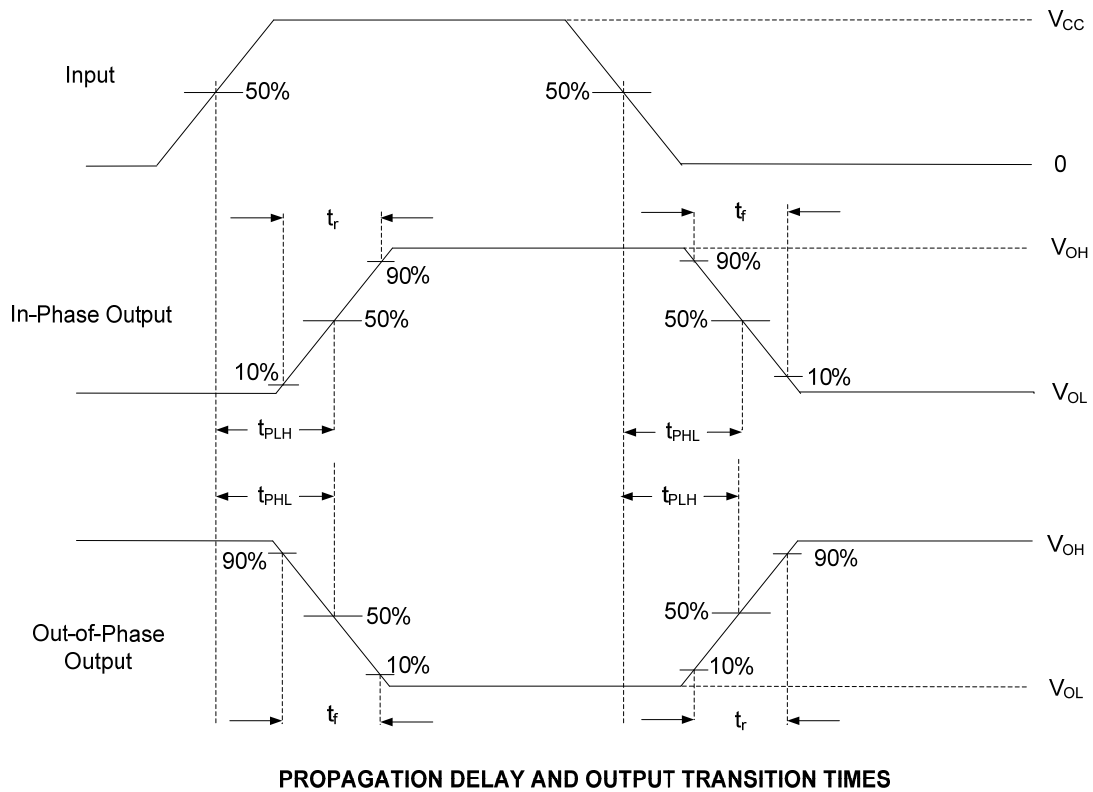

UTC assumes no responsibility for equipment failures that result from using products at values that exceed, even momentarily, rated values (such as maximum ratings, operating condition ranges, or other parameters) listed in products specifications of any and all UTC products described or contained herein. UTC products are not designed for use in life support appliances, devices or systems where malfunction of these products can be reasonably expected to result in personal injury. Reproduction in whole or in part is prohibited without the prior written consent of the copyright owner. UTC reserves the right to make changes to information published in this document, including without limitation specifications and product descriptions, at any time and without notice. This document supersedes and replaces all information supplied prior to the publication hereof.