



## U74HC4052

CMOS IC

### DUAL 4-CHANNEL ANALOG MULTIPLEXER, DEMULTIPLEXER

#### DESCRIPTION

The **U74HC4052** provides common select logic. Each multiplexer has four independent inputs/outputs and a common input/output.

#### FEATURES

- \* Wide analog input voltage range from -5V to +5V
- \* Low on-resistance
- \* Logic level translation: to enable 5V logic to communicate with ±5V analog signals
- \* Typical "break before make" built in

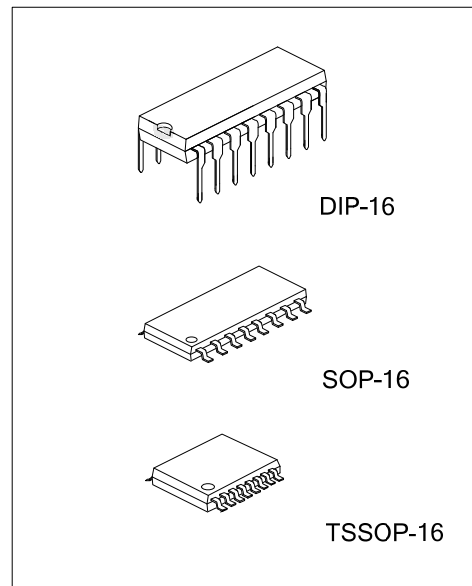

#### ORDERING INFORMATION

Ordering Number		Package	Packing
Lead Free	Halogen Free		
U74HC4052L-D16-T	U74HC4052G-D16-T	DIP-16	Tube
U74HC4052L-S16-R	U74HC4052G-S16-R	SOP-16	Tape Reel
U74HC4052L-P16-R	U74HC4052G-P16-R	TSSOP-16	Tape Reel

<p>U74HC4052G-D16-T</p> <p>(1) Packing Type (2) Package Type (3) Green Package</p>	<p>(1) T: Tube, R: Tape Reel (2) D16: DIP-16, S16: SOP-16, P16: TSSOP-16 (3) G: Halogen Free and Lead Free, L: Lead Free</p>
--	--

#### MARKING

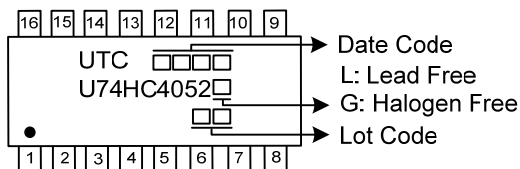

■ PIN CONFIGURATION

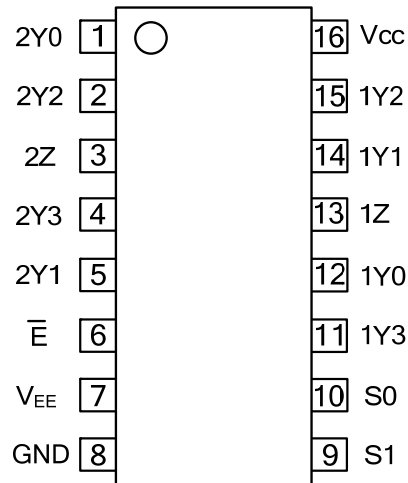

■ FUNCTION TABLE (each gate)

INPUT(E)	INPUT(S1)	INPUT(S0)	CHANNEL BETWEEN
L	L	L	nY0 and nZ
L	L	H	nY1 and nZ
L	H	L	nY2 and nZ
L	H	H	nY3 and nZ
H	X	X	none

Note: H=High voltage level; L=Low voltage level; X=don't care

FLYING 汎翔國際有限公司  
[www.flying1688.com](http://www.flying1688.com)



### ■ ABSOLUTE MAXIMUM RATINGS

PARAMETER		SYMBOL	RATINGS	UNIT
Supply Voltage		$V_{CC}$	-0.5~11	V
$V_{CC}$ or GND Current		$I_{CC}$	±50	mA
$V_{EE}$ Current		$I_{EE}$	±20	mA
Input Clamp Current		$I_{IK}$	±20	mA
Switch Diode Current		$I_{SK}$	±20	mA
Switch Current		$I_S$	±25	mA
Power Dissipation		$P_D$	500	mW
Derate above $T_A > 70^\circ\text{C}$	DIP-16		12	mW/K
	SOP-16		8	mW/K
Derate above $T_A > 60^\circ\text{C}$	TSSOP-16		5.5	mW/K
Storage Temperature		$T_{STG}$	-65 ~ +150	$^\circ\text{C}$

Note: Absolute maximum ratings are those values beyond which the device could be permanently damaged.

Absolute maximum ratings are stress ratings only and functional device operation is not implied.

### ■ RECOMMENDED OPERATING CONDITIONS

PARAMETER	SYMBOL	CONDITIONS	MIN	TYP	MAX	UNIT
Supply Voltage	$V_{CC}$	$V_{CC}$ -GND	2.0	5.0	10.0	V
		$V_{CC}$ - $V_{EE}$	2.0	5.0	10.0	V
Input Voltage	$V_{IN}$		GND		$V_{CC}$	V
Switch voltage	$V_S$		$V_{EE}$		$V_{CC}$	V
Input Transition Rise or Fall Rate	$t_R, t_F$	$V_{CC}=2.0\text{V}$		6.0	1000	ns
		$V_{CC}=4.5\text{V}$		6.0	500	ns
		$V_{CC}=6.0\text{V}$		6.0	400	ns
		$V_{CC}=10.0\text{V}$		6.0	250	ns
Operating Temperature	$T_A$		-40		+85	$^\circ\text{C}$

### ■ STATIC CHARACTERISTICS ( $T_A=25^\circ\text{C}$ )

PARAMETER	SYMBOL	TEST CONDITIONS	MIN	TYP	MAX	UNIT	
High-Level Input Voltage	$V_{IH}$	$V_{CC}=2.0\text{V}$	1.5	1.2		V	
		$V_{CC}=4.5\text{V}$	3.15	2.4		V	
		$V_{CC}=6.0\text{V}$	4.2	3.2		V	
		$V_{CC}=9.0\text{V}$	6.3	4.7		V	
Low-Level Input Voltage	$V_{IL}$	$V_{CC}=2.0\text{V}$		0.8	0.5	V	
		$V_{CC}=4.5\text{V}$		2.1	1.35	V	
		$V_{CC}=6.0\text{V}$		2.8	1.8	V	
		$V_{CC}=9.0\text{V}$		4.3	2.7	V	
Analog switch OFF-state current	$I_{S(OFF)}$	$V_{CC}=10\text{V}, V_{EE}=0\text{V}, V_{IN}=V_{IH}$ or $V_{IL}$ $ V_S =V_{CC}-V_{EE}$	per channel			±1	$\mu\text{A}$
			all channels			±2	$\mu\text{A}$
Analog switch ON-state current	$I_{S(ON)}$	$V_{CC}=10\text{V}, V_{EE}=0\text{V}, V_{IN}=V_{IH}$ or $V_{IL}$ $ V_S =V_{CC}-V_{EE}$			±2.0	$\mu\text{A}$	
Input Leakage Current	$I_{I(LEAK)}$	$V_{CC}=6\text{V}, V_{EE}=0\text{V}, V_{IN}=V_{CC}$ or GND			±1.0	$\mu\text{A}$	
		$V_{CC}=10\text{V}, V_{EE}=0\text{V}, V_{IN}=V_{CC}$ or GND			±2.0	$\mu\text{A}$	
Quiescent Supply Current	$I_Q$	$V_{IN}=V_{CC}$ or GND $V_{IS}=V_{EE}$ or $V_{CC}$ $V_{OS}=V_{CC}$ or $V_{EE}$	$V_{CC}=6\text{V}, V_{EE}=0\text{V}$			80	$\mu\text{A}$
			$V_{CC}=10\text{V}, V_{EE}=0\text{V}$			160	$\mu\text{A}$

■ STATIC CHARACTERISTICS(Cont.) (T<sub>A</sub>=25°C)

PARAMETER	SYMBOL	TEST CONDITIONS	MIN	TYP	MAX	UNIT	
ON-Resistance	PEAK	R <sub>ON(PEAK)</sub>	V <sub>CC</sub> =2V, V <sub>EE</sub> =0V, I <sub>S</sub> =100uA, V <sub>IS</sub> =V <sub>CC</sub> to V <sub>EE</sub> , V <sub>IN</sub> =V <sub>IH</sub> or V <sub>IL</sub> ,				Ω
			V <sub>CC</sub> =4.5V, V <sub>EE</sub> =0V, I <sub>S</sub> =1mA, V <sub>IS</sub> =V <sub>CC</sub> to V <sub>EE</sub> , V <sub>IN</sub> =V <sub>IH</sub> or V <sub>IL</sub> ,		100	225	Ω
			V <sub>CC</sub> =6V, V <sub>EE</sub> =0V, I <sub>S</sub> =1mA, V <sub>IS</sub> =V <sub>CC</sub> to V <sub>EE</sub> , V <sub>IN</sub> =V <sub>IH</sub> or V <sub>IL</sub>		90	200	Ω
			V <sub>CC</sub> =4.5V, V <sub>EE</sub> =-4.5V, I <sub>S</sub> =1mA, V <sub>IS</sub> =V <sub>CC</sub> to V <sub>EE</sub> , V <sub>IN</sub> =V <sub>IH</sub> or V <sub>IL</sub>		70	165	Ω
	RAIL	R <sub>ON(RAIL)</sub>	V <sub>CC</sub> =2V, V <sub>EE</sub> =0V, I <sub>S</sub> =100uA, V <sub>IS</sub> =V <sub>EE</sub> , V <sub>IN</sub> =V <sub>IH</sub> or V <sub>IL</sub> ,		150		Ω
			V <sub>CC</sub> =4.5V, V <sub>EE</sub> =0V, I <sub>S</sub> =1mA, V <sub>IS</sub> =V <sub>EE</sub> , V <sub>IN</sub> =V <sub>IH</sub> or V <sub>IL</sub> ,		80	175	Ω
			V <sub>CC</sub> =6V, V <sub>EE</sub> =0V, I <sub>S</sub> =1mA, V <sub>IS</sub> =V <sub>EE</sub> , V <sub>IN</sub> =V <sub>IH</sub> or V <sub>IL</sub>		70	150	Ω
			V <sub>CC</sub> =4.5V, V <sub>EE</sub> =-4.5V, I <sub>S</sub> =1mA, V <sub>IS</sub> =V <sub>EE</sub> , V <sub>IN</sub> =V <sub>IH</sub> or V <sub>IL</sub>		60	130	Ω
			V <sub>CC</sub> =2V, V <sub>EE</sub> =0V, I <sub>S</sub> =100uA, V <sub>IS</sub> =V <sub>CC</sub> , V <sub>IN</sub> =V <sub>IH</sub> or V <sub>IL</sub> ,		150		Ω
			V <sub>CC</sub> =4.5V, V <sub>EE</sub> =0V, I <sub>S</sub> =1mA, V <sub>IS</sub> =V <sub>CC</sub> , V <sub>IN</sub> =V <sub>IH</sub> or V <sub>IL</sub> ,		90	200	Ω
			V <sub>CC</sub> =6V, V <sub>EE</sub> =0V, I <sub>S</sub> =1mA, V <sub>IS</sub> =V <sub>CC</sub> , V <sub>IN</sub> =V <sub>IH</sub> or V <sub>IL</sub>		80	175	Ω
			V <sub>CC</sub> =4.5V, V <sub>EE</sub> =-4.5V, I <sub>S</sub> =1mA, V <sub>IS</sub> =V <sub>CC</sub> , V <sub>IN</sub> =V <sub>IH</sub> or V <sub>IL</sub>		65	150	Ω
Maximum On-Resistance Difference Between Any Two Channels	ΔR <sub>ON</sub>	V <sub>CC</sub> =2V, V <sub>EE</sub> =0V, V <sub>IS</sub> =V <sub>CC</sub> to V <sub>EE</sub> , V <sub>IN</sub> =V <sub>IH</sub> or V <sub>IL</sub> ,				Ω	
		V <sub>CC</sub> =4.5V, V <sub>EE</sub> =0V, V <sub>IS</sub> =V <sub>CC</sub> to V <sub>EE</sub> , V <sub>IN</sub> =V <sub>IH</sub> or V <sub>IL</sub> ,		9		Ω	
		V <sub>CC</sub> =6V, V <sub>EE</sub> =0V, V <sub>IS</sub> =V <sub>CC</sub> to V <sub>EE</sub> , V <sub>IN</sub> =V <sub>IH</sub> or V <sub>IL</sub>		8		Ω	
		V <sub>CC</sub> =4.5V, V <sub>EE</sub> =-4.5V, V <sub>IS</sub> =V <sub>CC</sub> to V <sub>EE</sub> , V <sub>IN</sub> =V <sub>IH</sub> or V <sub>IL</sub>		6		Ω	

■ DYNAMIC CHARACTERISTICS (T<sub>A</sub>=25°C, GND=0V; t<sub>R</sub>=t<sub>F</sub>=6ns; C<sub>L</sub>=50pF)

PARAMETER	SYMBOL	TEST CONDITIONS	MIN	TYP	MAX	UNIT
Propagation Delay From V <sub>IS</sub> to V <sub>OS</sub>	t <sub>PHL</sub> /t <sub>PLH</sub>	V <sub>CC</sub> =2V, V <sub>EE</sub> =0V, R <sub>L</sub> =∞		14	75	ns
		V <sub>CC</sub> =4.5V, V <sub>EE</sub> =0V, R <sub>L</sub> =∞		5	15	ns
		V <sub>CC</sub> =6V, V <sub>EE</sub> =0V, R <sub>L</sub> =∞		4	13	ns
		V <sub>CC</sub> =4.5V, V <sub>EE</sub> =-4.5V, R <sub>L</sub> =∞		4	10	ns
Turn-ON Time $\bar{E}$ Sn to V <sub>OS</sub>	t <sub>PZH</sub> /t <sub>PZL</sub>	V <sub>CC</sub> =2V, V <sub>EE</sub> =0V, R <sub>L</sub> =∞		105	405	ns
		V <sub>CC</sub> =4.5V, V <sub>EE</sub> =0V, R <sub>L</sub> =∞		38	81	ns
		V <sub>CC</sub> =6V, V <sub>EE</sub> =0V, R <sub>L</sub> =∞		30	69	ns
		V <sub>CC</sub> =4.5V, V <sub>EE</sub> =-4.5V, R <sub>L</sub> =∞		26	58	ns
Turn-OFF Time $\bar{E}$ Sn to V <sub>OS</sub>	t <sub>PHZ</sub> /t <sub>PLZ</sub>	V <sub>CC</sub> =2V, V <sub>EE</sub> =0V, R <sub>L</sub> =1k		74	315	ns
		V <sub>CC</sub> =4.5V, V <sub>EE</sub> =0V, R <sub>L</sub> =1k		27	63	ns
		V <sub>CC</sub> =6V, V <sub>EE</sub> =0V, R <sub>L</sub> =1k		22	54	ns
		V <sub>CC</sub> =4.5V, V <sub>EE</sub> =-4.5V, R <sub>L</sub> =1k		22	48	ns

## ■ TEST CIRCUIT AND WAVEFORMS

### Test circuit for measuring OFF-state current

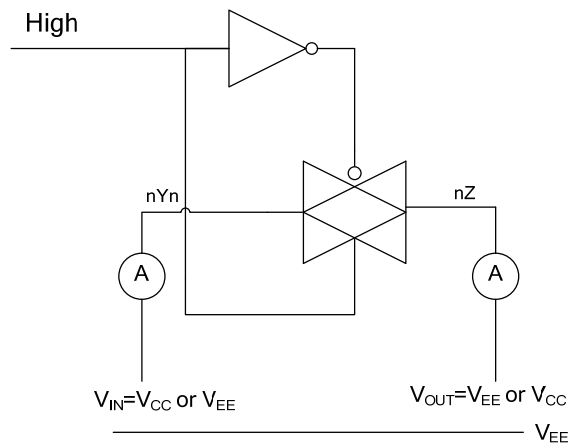

### Test circuit for measuring ON-state current

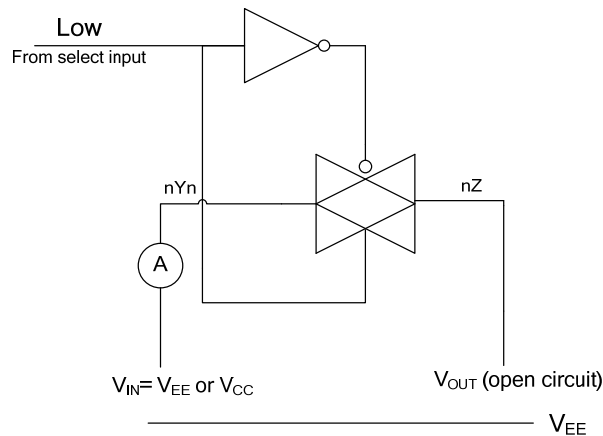

### Test circuit for measuring RON

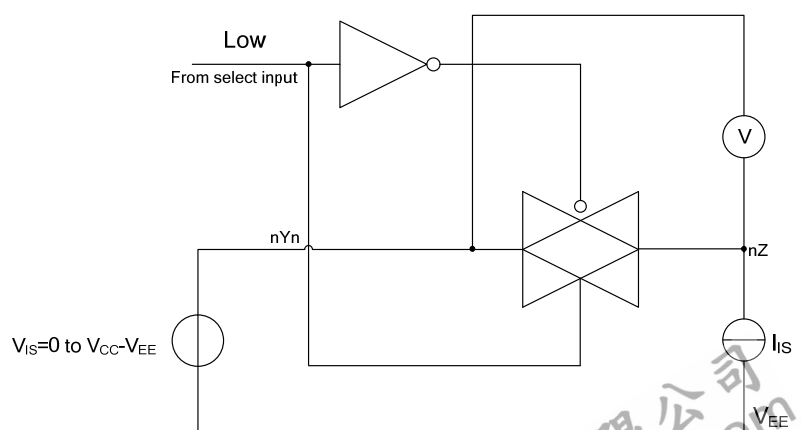

■ TEST CIRCUIT AND WAVEFORMS(Cont.)

Waveforms showing the Input ( $V_{IS}$ ) to Output ( $V_{OS}$ ) propagation delays

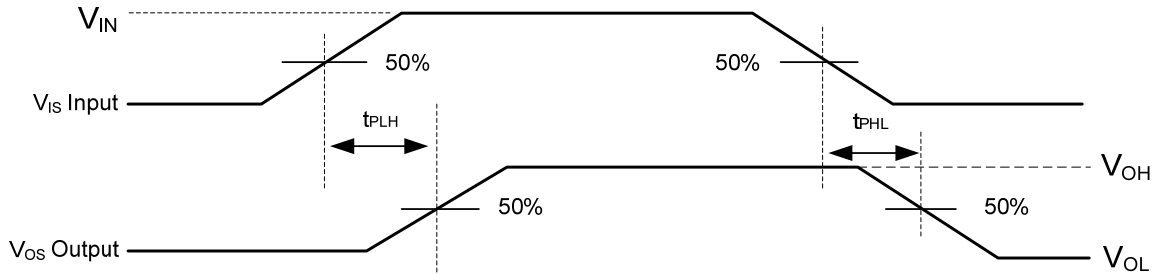

Waveforms showing the turn-on and turn-off times.

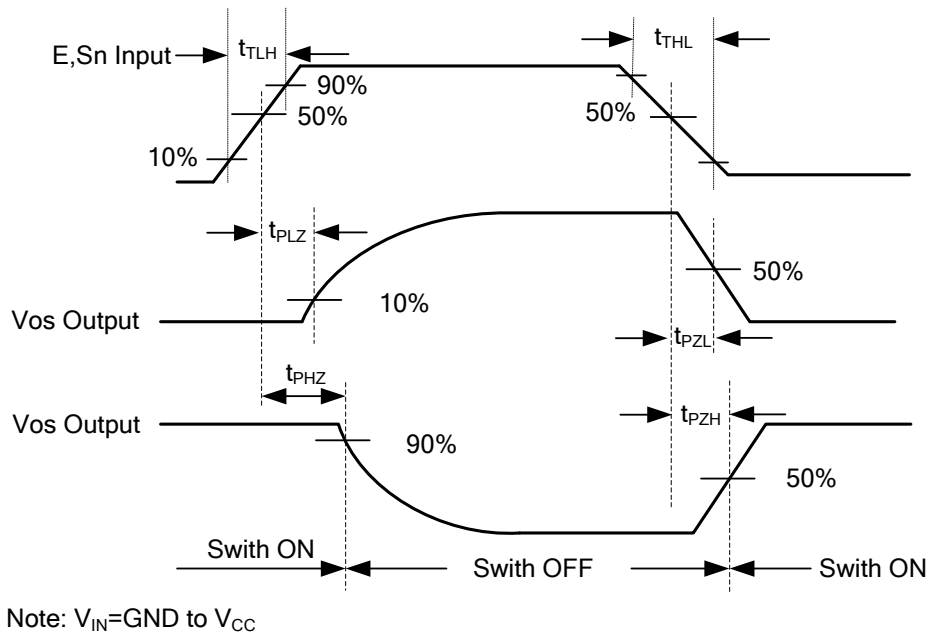

## ■ TEST CIRCUIT AND WAVEFORMS(Cont.)

### Input pulse definitions

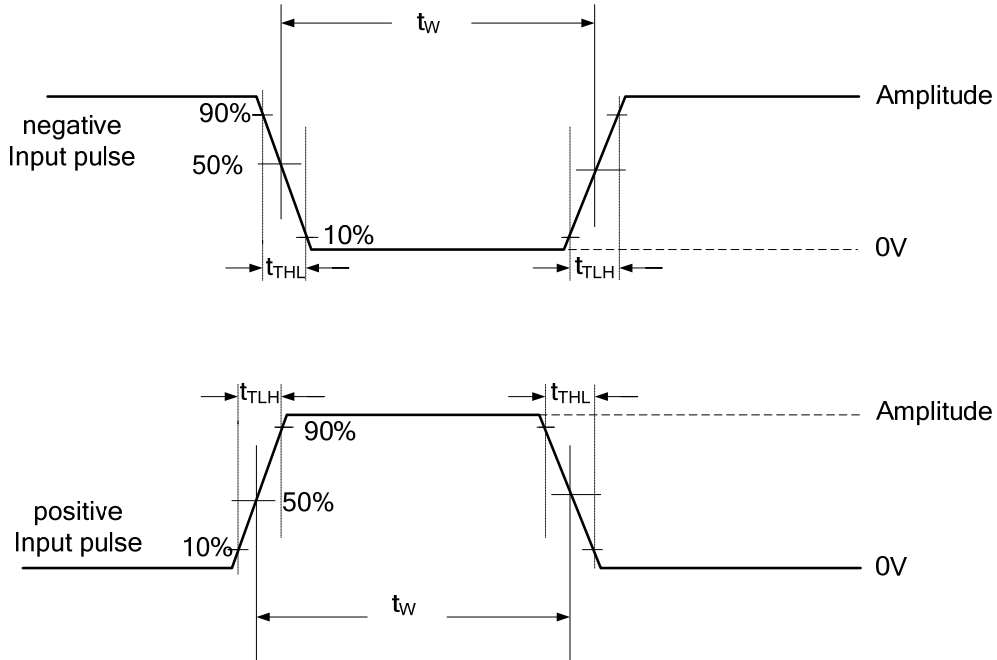

### Test circuit for measuring AC performance.

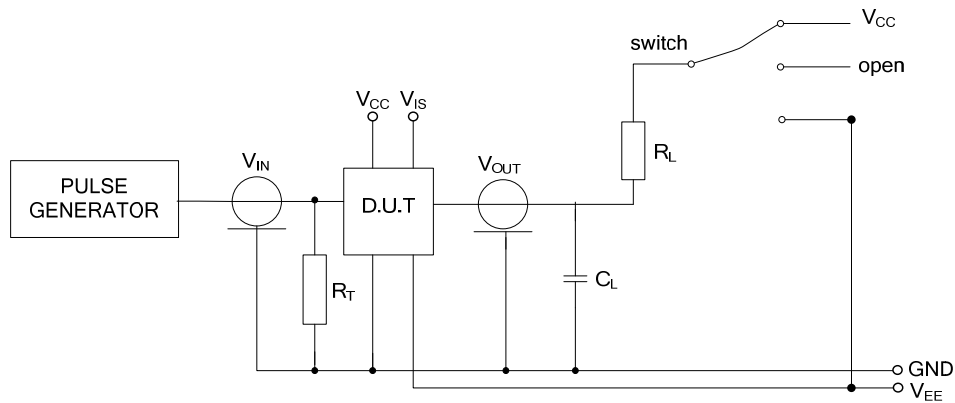

TEST	SWITCH	$V_{IS}$
$t_{PZH}$	$V_{EE}$	$V_{CC}$
$t_{PZL}$	$V_{CC}$	$V_{EE}$
$t_{PHZ}$	$V_{EE}$	$V_{CC}$
$t_{PLZ}$	$V_{CC}$	$V_{EE}$
other	open	pulse

NOTE: Definitions for test circuit:

$R_L$  = load resistance

$C_L$  = load capacitance including jig and probe capacitance.

$R_T$  = termination resistance should be equal to the output impedance  $Z_O$  of the pulse generator.

$t_{THL}=t_{TLH}=6$  ns; when measuring  $f_{MAX}$ , there is no constraint to  $t_{THL}$  and  $t_{TLH}$  with 50% duty factor.



UTC assumes no responsibility for equipment failures that result from using products at values that exceed, even momentarily, rated values (such as maximum ratings, operating condition ranges, or other parameters) listed in products specifications of any and all UTC products described or contained herein. UTC products are not designed for use in life support appliances, devices or systems where malfunction of these products can be reasonably expected to result in personal injury. Reproduction in whole or in part is prohibited without the prior written consent of the copyright owner. UTC reserves the right to make changes to information published in this document, including without limitation specifications and product descriptions, at any time and without notice. This document supersedes and replaces all information supplied prior to the publication hereof.