



## U74HC4066

CMOS IC

### QUAD BILATERAL SWITCHES

#### DESCRIPTION

The UTC **U74HC4066** consists of four independent analog switches. Each switch has an Enable input (nE) which is active HIGH to decide the switch status.

#### FEATURES

- \* Operation voltage range: 2~10V
- \* Very low "ON" resistance:  $V_{CC}=4.5V, 50\Omega$   
 $V_{CC}=6V, 45\Omega$   
 $V_{CC}=9V, 35\Omega$

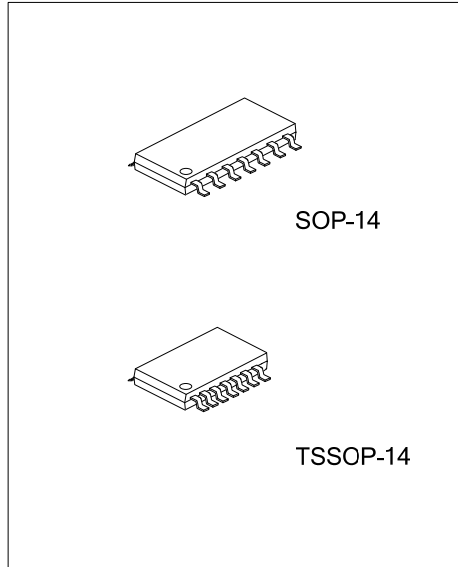

#### ORDERING INFORMATION

Ordering Number		Package	Packing
Lead Free	Halogen Free		
U74HC4066L-S14-R	U74HC4066G-S14-R	SOP-14	Tape Reel
U74HC4066L-P14-R	U74HC4066G-P14-R	TSSOP-14	Tape Reel

<p>U74HC4066G-S14-R</p>	<p>(1) Packing Type      (1) R: Tape Reel</p> <p>(2) Package Type      (2) S14: SOP-14, P14: TSSOP-14</p> <p>(3) Green Package      (3) G: Halogen Free and Lead Free, L: Lead Free</p>
-------------------------	---

#### MARKING

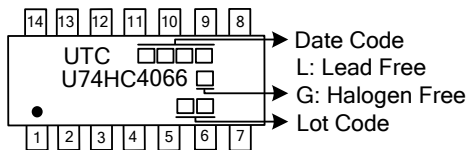

■ PIN CONFIGURATION

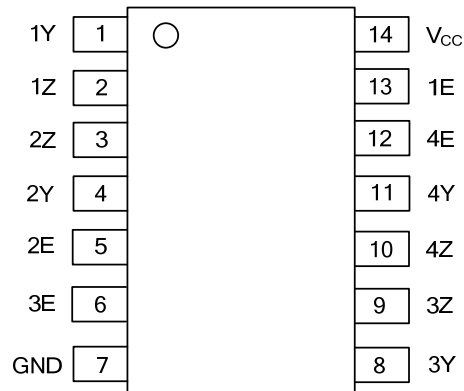

■ FUNCTION TABLE

INPUTS(nE)	SWITCH
H	ON
L	OFF

Note: H: High voltage level; L: Low voltage level.

■ LOGIC DIAGRAM

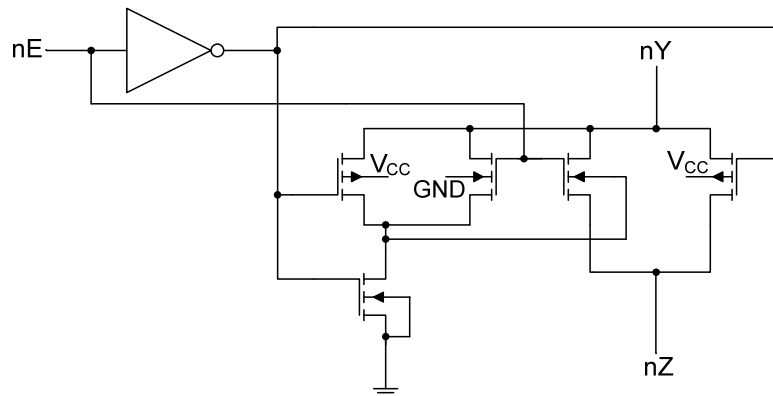

■ ABSOLUTE MAXIMUM RATING (T<sub>A</sub>=25°C, unless otherwise specified)

PARAMETER	SYMBOL	RATINGS	UNIT	
Supply Voltage	V <sub>CC</sub>	-0.5 ~ +11	V	
Input Diode Current	I <sub>IK</sub>	±20	mA	
Switch Diode Current	I <sub>SK</sub>	±20	mA	
Switch Current	I <sub>S</sub>	±25	mA	
V <sub>CC</sub> or GND Current	I <sub>CC</sub>	±50	mA	
Power Dissipation	P <sub>D</sub>	500	mW	
Derate above 70°C		SOP-14	8	mW/K
Derate above 60°C		TSSOP-14	5.5	mW/K
Storage Temperature	T <sub>STG</sub>	-65 ~ +150	°C	

Note: Absolute maximum ratings are those values beyond which the device could be permanently damaged. Absolute maximum ratings are stress ratings only and functional device operation is not implied.

■ RECOMMENDED OPERATING CONDITIONS

PARAMETER	SYMBOL	TEST CONDITIONS	MIN	TYP	MAX	UNIT
Supply Voltage	V <sub>CC</sub>		2.0	5.0	10.0	V
Input Voltage	V <sub>IN</sub>		GND		V <sub>CC</sub>	V
Switch Voltage	V <sub>S</sub>		GND		V <sub>CC</sub>	V
Input Transition Rise or Fall Rate	t <sub>R</sub> , t <sub>F</sub>	V <sub>CC</sub> =2.0V		6	1000	ns
		V <sub>CC</sub> =4.5V			500	ns
		V <sub>CC</sub> =6.0V			400	ns
		V <sub>CC</sub> =10.0V			250	ns
Operating Temperature	T <sub>A</sub>		-40		85	°C

■ ELECTRICAL CHARACTERISTICS (T<sub>A</sub>=25°C, unless otherwise specified)

PARAMETER		SYMBOL	TEST CONDITIONS	MIN	TYP	MAX	UNIT			
High-Level Input Voltage		V <sub>IH</sub>	V <sub>CC</sub> =2.0V	1.5			V			
			V <sub>CC</sub> =4.5V	3.15			V			
			V <sub>CC</sub> =6.0V	4.2			V			
			V <sub>CC</sub> =9.0V	6.3			V			
Low-Level Input Voltage		V <sub>IL</sub>	V <sub>CC</sub> =2.0V			0.50	V			
			V <sub>CC</sub> =4.5V			1.35	V			
			V <sub>CC</sub> =6.0V			1.80	V			
			V <sub>CC</sub> =9.0V			2.70	V			
Input Leakage Current		I <sub>I(LEAK)</sub>	V <sub>CC</sub> =6V, V <sub>IN</sub> =V <sub>CC</sub> or GND			±1.0	µA			
			V <sub>CC</sub> =10V, V <sub>IN</sub> =V <sub>CC</sub> or GND			±2.0	µA			
current per channel	OFF-state	I <sub>S</sub>	V <sub>CC</sub> =10V, V <sub>IN</sub> =V <sub>IH</sub> or V <sub>IL</sub> , V <sub>S</sub> =V <sub>CC</sub> -GND			±1.0	µA			
	ON-state					±1.0	µA			
Quiescent Supply Current		I <sub>Q</sub>	V <sub>CC</sub> =6V, V <sub>IN</sub> =V <sub>IS</sub> =V <sub>OS</sub> =V <sub>CC</sub> or GND			20	µA			
			V <sub>CC</sub> =10V, V <sub>IN</sub> =V <sub>IS</sub> =V <sub>OS</sub> =V <sub>CC</sub> or GND			40	µA			
ON-resistance	Peak	R <sub>ON</sub>	V <sub>CC</sub> =4.5V, I <sub>S</sub> =1mA, V <sub>IN</sub> =V <sub>IH</sub> or V <sub>IL</sub> , V <sub>IS</sub> =V <sub>CC</sub> to GND		54	118	Ω			
			V <sub>CC</sub> =6.0V, I <sub>S</sub> =1mA, V <sub>IN</sub> =V <sub>IH</sub> or V <sub>IL</sub> , V <sub>IS</sub> =V <sub>CC</sub> to GND		42	105	Ω			
			V <sub>CC</sub> =9.0V, I <sub>S</sub> =1mA, V <sub>IN</sub> =V <sub>IH</sub> or V <sub>IL</sub> , V <sub>IS</sub> =V <sub>CC</sub> to GND		32	88	Ω			
			V <sub>CC</sub> =2.0V, I <sub>S</sub> =100µA, V <sub>IN</sub> =V <sub>IH</sub> or V <sub>IL</sub> , V <sub>IS</sub> =GND		80		Ω			
	Rail		V <sub>CC</sub> =4.5V, I <sub>S</sub> =1mA, V <sub>IN</sub> =V <sub>IH</sub> or V <sub>IL</sub> , V <sub>IS</sub> =GND		35	95	Ω			
			V <sub>CC</sub> =6.0V, I <sub>S</sub> =1mA, V <sub>IN</sub> =V <sub>IH</sub> or V <sub>IL</sub> , V <sub>IS</sub> =GND		27	82	Ω			
			V <sub>CC</sub> =9.0V, I <sub>S</sub> =1mA, V <sub>IN</sub> =V <sub>IH</sub> or V <sub>IL</sub> , V <sub>IS</sub> =GND		20	70	Ω			
			V <sub>CC</sub> =2.0V, I <sub>S</sub> =100µA, V <sub>IN</sub> =V <sub>IH</sub> or V <sub>IL</sub> , V <sub>IS</sub> =V <sub>CC</sub>		100		Ω			
			V <sub>CC</sub> =4.5V, I <sub>S</sub> =1mA, V <sub>IN</sub> =V <sub>IH</sub> or V <sub>IL</sub> , V <sub>IS</sub> =V <sub>CC</sub>		42	106	Ω			
			V <sub>CC</sub> =6.0V, I <sub>S</sub> =1mA, V <sub>IN</sub> =V <sub>IH</sub> or V <sub>IL</sub> , V <sub>IS</sub> =V <sub>CC</sub>		35	94	Ω			
			V <sub>CC</sub> =9.0V, I <sub>S</sub> =1mA, V <sub>IN</sub> =V <sub>IH</sub> or V <sub>IL</sub> , V <sub>IS</sub> =V <sub>CC</sub>		27	78	Ω			
			Maximum variation of ON-resistance between any two channels		ΔR <sub>ON</sub>	V <sub>CC</sub> =4.5V, V <sub>IN</sub> =V <sub>IH</sub> or V <sub>IL</sub> , V <sub>IS</sub> =V <sub>CC</sub> to GND		5		Ω
						V <sub>CC</sub> =6.0V, V <sub>IN</sub> =V <sub>IH</sub> or V <sub>IL</sub> , V <sub>IS</sub> =V <sub>CC</sub> to GND		4		Ω
						V <sub>CC</sub> =9.0V, V <sub>IN</sub> =V <sub>IH</sub> or V <sub>IL</sub> , V <sub>IS</sub> =V <sub>CC</sub> to GND		3		Ω

■ DYNAMIC CHARACTERISTICS (T<sub>A</sub>=25°C, GND=0V; t<sub>r</sub>=t<sub>f</sub>=6ns; C<sub>L</sub>=50pF)

PARAMETER	SYMBOL	TEST CONDITIONS	MIN	TYP	MAX	UNIT
Propagation Delay From V <sub>IS</sub> to V <sub>OS</sub>	t <sub>PHL</sub> /t <sub>PLH</sub>	V <sub>CC</sub> =2.0V, R <sub>L</sub> =∞		8	75	ns
		V <sub>CC</sub> =4.5V, R <sub>L</sub> =∞		3	15	ns
		V <sub>CC</sub> =6.0V, R <sub>L</sub> =∞		2	13	ns
		V <sub>CC</sub> =9.0V, R <sub>L</sub> =∞		2	10	ns
Turn-ON Time from nE to V <sub>OS</sub>	t <sub>PZH</sub> /t <sub>PZL</sub>	V <sub>CC</sub> =2.0V, R <sub>L</sub> =1KΩ		36	125	ns
		V <sub>CC</sub> =4.5V, R <sub>L</sub> =1KΩ		13	25	ns
		V <sub>CC</sub> =6.0V, R <sub>L</sub> =1KΩ		10	21	ns
		V <sub>CC</sub> =9.0V, R <sub>L</sub> =1KΩ		8	16	ns
Turn-OFF Time from nE to V <sub>OS</sub>	t <sub>PHZ</sub> /t <sub>PLZ</sub>	V <sub>CC</sub> =2.0V, R <sub>L</sub> =1KΩ		44	190	ns
		V <sub>CC</sub> =4.5V, R <sub>L</sub> =1KΩ		16	38	ns
		V <sub>CC</sub> =6.0V, R <sub>L</sub> =1KΩ		13	33	ns
		V <sub>CC</sub> =9.0V, R <sub>L</sub> =1KΩ		16	26	ns
Sine-Wave Distortion	THD	V <sub>CC</sub> =4.5V, V <sub>IS(P-P)</sub> =4V, f=1kHz, R <sub>L</sub> =10k		0.04		%
		V <sub>CC</sub> =9V, V <sub>IS(P-P)</sub> =8V, f=1kHz, R <sub>L</sub> =10k		0.02		%
		V <sub>CC</sub> =4.5V, V <sub>IS(P-P)</sub> =4V, f=10kHz, R <sub>L</sub> =10k		0.12		%
		V <sub>CC</sub> =9V, V <sub>IS(P-P)</sub> =8V, f=10kHz, R <sub>L</sub> =10k		0.06		%
Switch OFF Signal Feed-Through (Note 1)	α <sub>OFF</sub>	V <sub>CC</sub> =4.5V, R <sub>L</sub> =600Ω, f=1MHz		-50		dB
		V <sub>CC</sub> =9V, R <sub>L</sub> =600Ω, f=1MHz		-50		dB
Crosstalk Between any two Switches (Note 1)	α <sub>CT(S)</sub>	V <sub>CC</sub> =4.5V, R <sub>L</sub> =600Ω, f=1MHz		-60		dB
		V <sub>CC</sub> =9V, R <sub>L</sub> =600Ω, f=1MHz		-60		dB
Crosstalk Voltage Between any input to any Switch (Peak-to-Peak Value)	V <sub>(P-P)</sub>	V <sub>CC</sub> =4.5V, R <sub>L</sub> =600Ω, f=1MHz		110		mV
		V <sub>CC</sub> =9V, R <sub>L</sub> =600Ω, f=1MHz		220		mV
Minimum Frequency Response(-3dB) (Note 2)	f <sub>MAX</sub>	V <sub>CC</sub> =4.5V, R <sub>L</sub> =50Ω, C <sub>L</sub> =10pF		180		MHz
		V <sub>CC</sub> =9V, R <sub>L</sub> =50Ω, C <sub>L</sub> =10pF		200		MHz
maximum switch capacitance	C <sub>S</sub>			8		pF

Note 1. Adjust input voltage V<sub>IS</sub> is 0dbm level (0dbm=1mW into 600Ω)

2. Adjust input voltage V<sub>IS</sub> is 0dbm level at V<sub>OS</sub> for 1MHz (0dbm=1mW into 50Ω)

## ■ TEST CIRCUIT AND WAVEFORMS

### Test circuit for measuring ON-resistance (Ron)

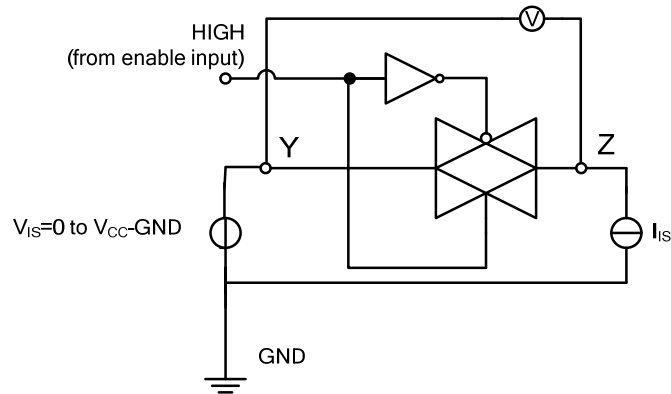

### Test circuit for measuring OFF-state current

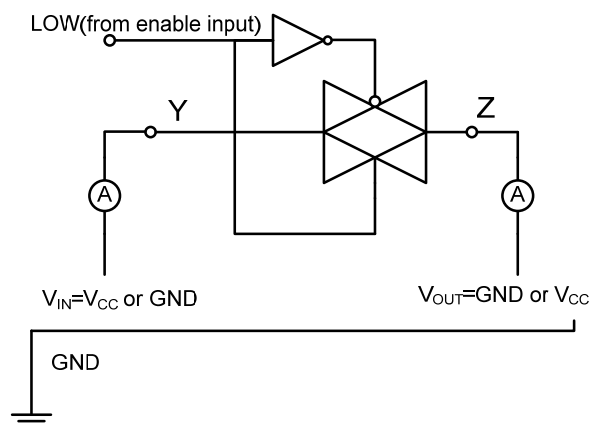

### Test circuit for measuring ON-state current

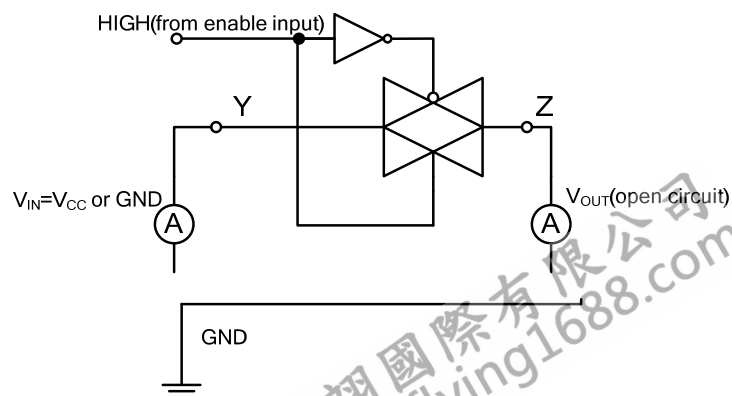

## ■ TEST CIRCUIT AND WAVEFORMS(Cont.)

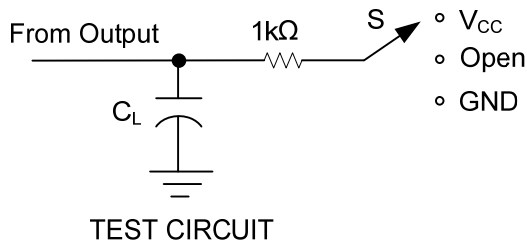

	S	V <sub>IN</sub>
t <sub>PLH</sub> /t <sub>PHL</sub>	OPEN	V <sub>CC</sub>
t <sub>PHZ</sub> /t <sub>PZH</sub>	GND	V <sub>CC</sub>
t <sub>PLZ</sub> /t <sub>PZL</sub>	V <sub>CC</sub>	GND

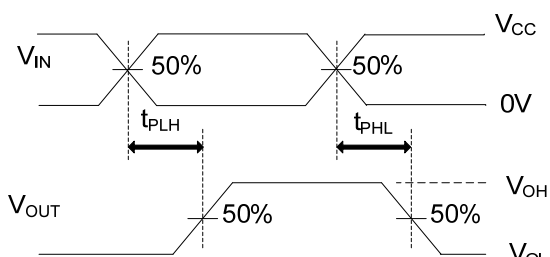

**PROPAGATION DELAY TIMES**

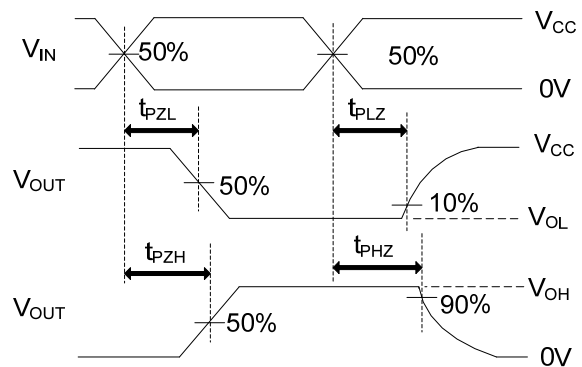

**ENABLE AND DISABLE TIMES**

Note: 1. C<sub>L</sub> includes probe and jig capacitance.  
 Note: 2. PRR ≤ 1MHz, Z<sub>o</sub> = 50Ω, t<sub>r</sub> ≤ 6ns, t<sub>f</sub> ≤ 6ns.

UTC assumes no responsibility for equipment failures that result from using products at values that exceed, even momentarily, rated values (such as maximum ratings, operating condition ranges, or other parameters) listed in products specifications of any and all UTC products described or contained herein. UTC products are not designed for use in life support appliances, devices or systems where malfunction of these products can be reasonably expected to result in personal injury. Reproduction in whole or in part is prohibited without the prior written consent of the copyright owner. UTC reserves the right to make changes to information published in this document, including without limitation specifications and product descriptions, at any time and without notice. This document supersedes and replaces all information supplied prior to the publication hereof.