



U74HCT125

CMOS IC

QUADRUPLE BUS BUFFER GATES WITH 3-STATE OUTPUTS

DESCRIPTION

The **U74HCT125** is a quadruple bus buffer gates with 3-state output. When \overline{OE} is high, the Y outputs are in a high-impedance state. When \overline{OE} is low, the device passes noninverted data from the A input to the Y output.

To ensure the high-impedance state during power up or power down, \overline{OE} should be tied to V_{CC} through a pull-up resistor; the minimum value of the resistor is determined by the current-sinking capability of the driver.

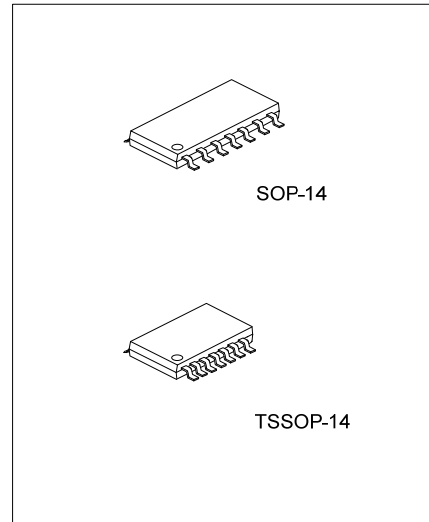

FEATURES

- * TTL-Voltage Compatible
- * Max t_{PD} of 12 ns from A to Y at 5.5 V, $C_L = 50$ pF
- * Low power consumption, $I_{CC} = 8\mu A$ (Max) at 5.5V
- * $\pm 6mA$ output driver at 5V

ORDERING INFORMATION

Ordering Number		Package	Packing
Lead Free	Halogen Free		
U74HCT125L-P14-R	U74HCT125G-P14-R	SOP-14	Tape Reel
U74HCT125L-S14-R	U74HCT125G-S14-R	TSSOP-14	Tape Reel

<p>U74HCT125G-P14-R</p> <p>(1) Packing Type (2) Package Type (3) Green Package</p>	<p>(1) R: Tape Reel (2) S14: SOP-14, P14: TSSOP-14 (3) G: Halogen Free and Lead Free, L: Lead Free</p>
--	--

MARKING

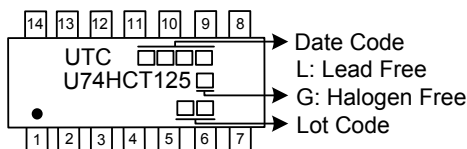

■ PIN CONFIGURATION

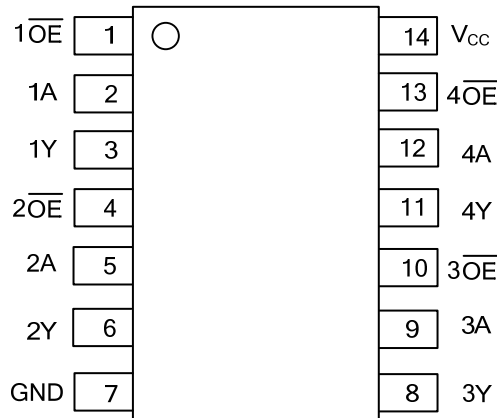

■ FUNCTION TABLE (each buffer)

INPUTS		OUTPUTS
\overline{OE}	A	Y
L	H	H
L	L	L
H	X	Z

■ LOGIC DIAGRAM (each buffer)

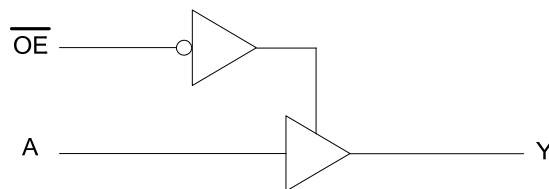

FLYING 汎翔國際有限公司
www.flying1688.com

■ ABSOLUTE MAXIMUM RATING (unless otherwise specified)

PARAMETER	SYMBOL	RATINGS	UNIT
Supply Voltage	V_{CC}	-0.5~7	V
Input Voltage	V_{IN}	-0.5~7	V
Output Voltage	V_{OUT}	-0.5~ V_{CC} +0.5	V
Input Clamp Current ($V_{IN}<0$, or $V_{IN}>0$)	I_{IK}	±20	mA
Output Clamp Current ($V_{OUT}<0$, or $V_{OUT}>V_{CC}$)	I_{OK}	±20	mA
Output Current	I_{OUT}	±35	mA
V_{CC} or GND Current	I_{CC}	±70	mA
Storage Temperature	T_{STG}	-65 ~ +150	°C

Note: 1. The input and output voltage ratings may be exceeded if the input and output current ratings are observed.

2. Absolute maximum ratings are those values beyond which the device could be permanently damaged.

Absolute maximum ratings are stress ratings only and functional device operation is not implied.

■ RECOMMENDED OPERATING CONDITIONS

PARAMETER	SYMBOL	MIN	TYP	MAX	UNIT
Supply Voltage	V_{CC}	4.5	5	5.5	V
High-Level Input Voltage ($V_{CC}=4.5V$ to 5.5V)	V_{IH}	2			V
Low-Level Input Voltage ($V_{CC}=4.5V$ to 5.5V)	V_{IL}			0.8	V
Input Voltage	V_{IN}	0		V_{CC}	V
Output Voltage	V_{OUT}	0		V_{CC}	V
Input Transition Rise or Fall Rate	$\Delta t/\Delta v$			500	ns/V
Operating Temperature	T_A	-40	25	85	°C

■ ELECTRICAL CHARACTERISTICS ($T_A=25^\circ\text{C}$, unless otherwise specified)

PARAMETER	SYMBOL	TEST CONDITIONS	MIN	TYP	MAX	UNIT
High-Level Output Voltage	V_{OH}	$I_{OH} = -20\mu\text{A}$, $V_{CC} = 4.5\text{V}$	4.4	4.5		V
		$I_{OH} = -6\text{mA}$, $V_{CC} = 4.5\text{V}$	3.98	4.3		
Low-Level Output Voltage	V_{OL}	$I_{OL} = 20\mu\text{A}$, $V_{CC} = 4.5\text{V}$		0.001	0.1	V
		$I_{OL} = 6\text{mA}$, $V_{CC} = 4.5\text{V}$		0.17	0.26	
Input Leakage Current (A or $\overline{\text{OE}}$ input)	$I_{I(\text{LEAK})}$	$V_{IN} = 5.5\text{V}$ or GND, $V_{CC} = 5.5\text{V}$		±0.1	±100	μA
High-Impedance State Current	I_{OZ}	$V_{OUT} = V_{CC}$ or GND, $V_{CC} = 5.5\text{V}$		±0.01	±0.5	μA
Quiescent Supply Current	I_{CC}	$V_{IN} = V_{CC}$ or GND, $I_{OUT} = 0$, $V_{CC} = 5.5\text{V}$			8	μA
Additional Quiescent Supply Current	ΔI_{CC}	One input at 0.5V or 2.4V, $V_{CC} = 5.5\text{V}$, other inputs at V_{CC} or GND		1.4	2.4	mA
Input Capacitance	C_{IN}	$V_{CC} = 4.5\text{V}$ to 5.5V		3	10	pF

■ SWITCHING CHARACTERISTICS

($C_L = 50 \text{ pF}$, $T_A = 25^\circ\text{C}$)

PARAMETER	SYMBOL	TEST CONDITIONS	MIN	TYP	MAX	UNIT
Propagation Delay from Input A to Output Y, t_{PD}	t_{PLH}/t_{PHL}	$V_{CC} = 4.5 \text{ V}$		15	26	ns
		$V_{CC} = 5.5 \text{ V}$		12	23	
Propagation Delay from Input \overline{OE} to Output Y, t_{EN}	t_{PZH}/t_{PZL}	$V_{CC} = 4.5 \text{ V}$		18	28	ns
		$V_{CC} = 5.5 \text{ V}$		15	25	
Propagation delay from input OE to output Y, t_{DIS}	t_{PHZ}/t_{PLZ}	$V_{CC} = 4.5 \text{ V}$		15	26	ns
		$V_{CC} = 5.5 \text{ V}$		13	23	
Output transition (rise and fall) time, t_T	t_{TLH}/t_{THL}	$V_{CC} = 4.5 \text{ V}$		8	15	ns
		$V_{CC} = 5.5 \text{ V}$		7	14	

($C_L = 150 \text{ pF}$, $T_A = 25^\circ\text{C}$)

PARAMETER	SYMBOL	TEST CONDITIONS	MIN	TYP	MAX	UNIT
Propagation Delay from Input A to Output Y, t_{PD}	t_{PLH}/t_{PHL}	$V_{CC} = 4.5 \text{ V}$		19	36	ns
		$V_{CC} = 5.5 \text{ V}$		16	32	
Propagation Delay from Input \overline{OE} to Output Y, t_{EN}	t_{PZH}/t_{PZL}	$V_{CC} = 4.5 \text{ V}$		25	40	ns
		$V_{CC} = 5.5 \text{ V}$		21	35	
Output transition (rise and fall) time, t_T	t_{TLH}/t_{THL}	$V_{CC} = 4.5 \text{ V}$		17	42	ns
		$V_{CC} = 5.5 \text{ V}$		14	38	

■ OPERATING CHARACTERISTICS ($T_A = 25^\circ\text{C}$)

PARAMETER	SYMBOL	TEST CONDITIONS	TYP	UNIT
Power dissipation capacitance	C_{PD}		35	pF

■ TEST CIRCUIT AND WAVEFORMS

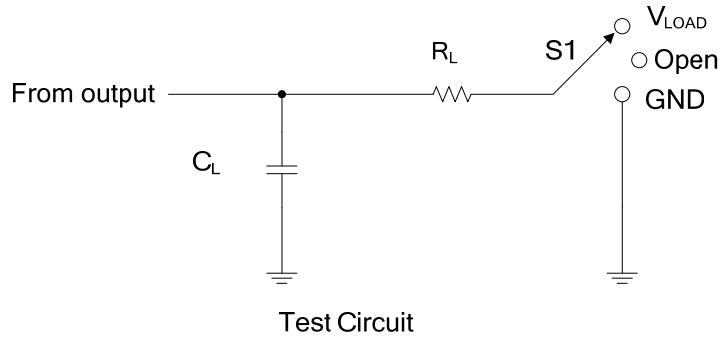

TEST	S1
t_{PLH}/t_{PHL}	Open
t_{PLZ}/t_{PZL}	V_{LOAD}
t_{PHZ}/t_{PZH}	GND

V_{CC}	Input		V_M	V_{LOAD}	C_L	R_L	V_{Δ}
	V_{IN}	t_R, t_F					
5V±0.5V	V_{CC}	≤3ns	$V_{CC}/2$	V_{CC}	50pF	1kΩ	0.5V
					150pF		

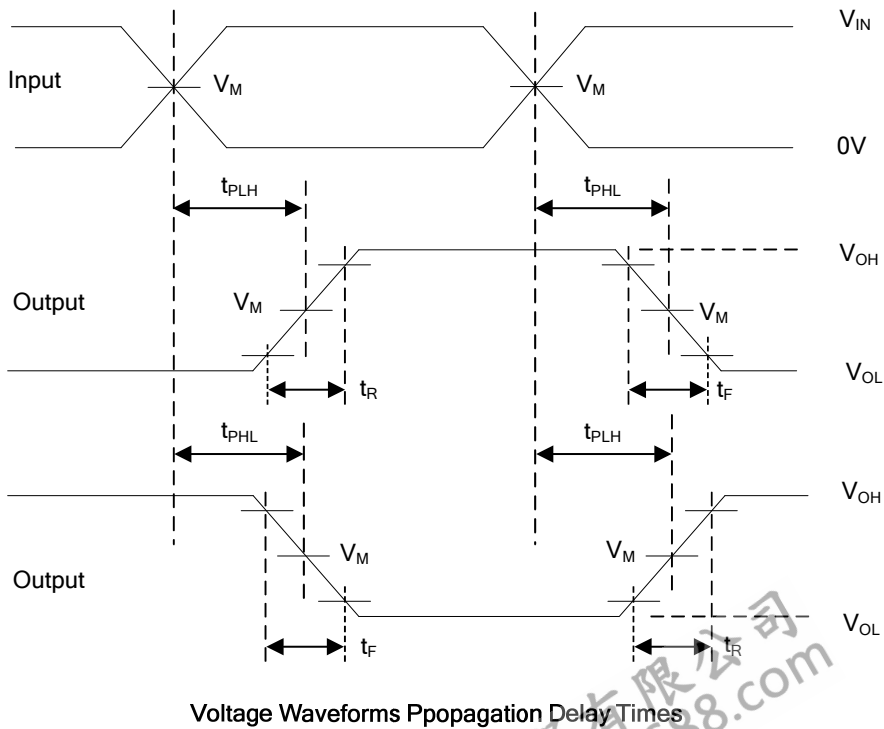

■ TEST CIRCUIT AND WAVEFORMS (Cont.)

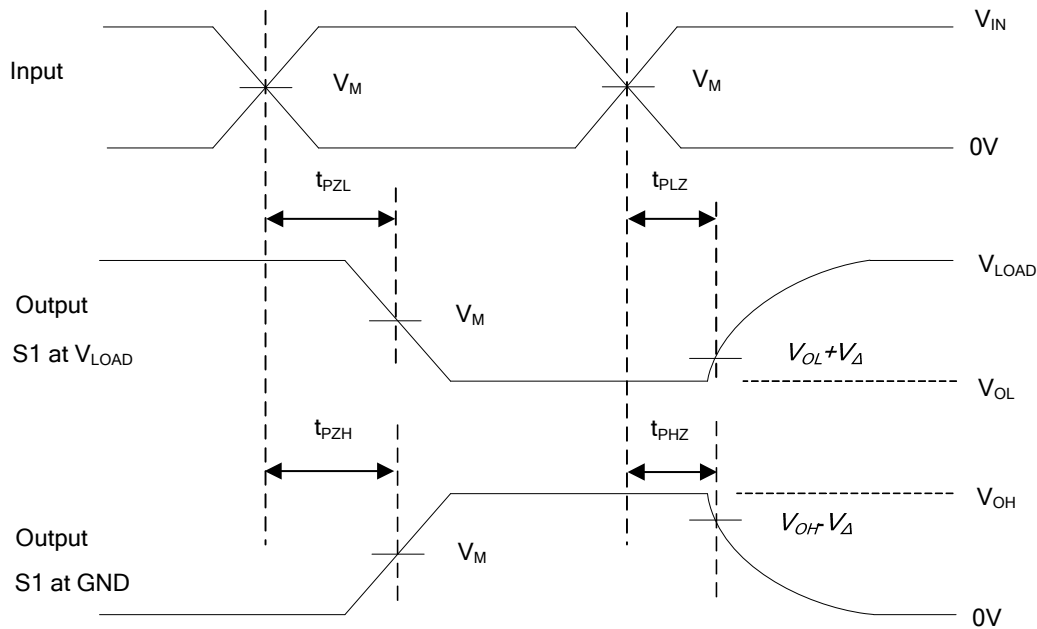

Voltage Waveforms Enable and Disable Times

- Notes: 1. C_L includes probe and jig capacitance.
 2. All input pulses are supplied by generators having the following characteristics: $P_{RR} \leq 1\text{MHz}$, $Z_O = 50\Omega$.

UTC assumes no responsibility for equipment failures that result from using products at values that exceed, even momentarily, rated values (such as maximum ratings, operating condition ranges, or other parameters) listed in products specifications of any and all UTC products described or contained herein. UTC products are not designed for use in life support appliances, devices or systems where malfunction of these products can be reasonably expected to result in personal injury. Reproduction in whole or in part is prohibited without the prior written consent of the copyright owner. UTC reserves the right to make changes to information published in this document, including without limitation specifications and product descriptions, at any time and without notice. This document supersedes and replaces all information supplied prior to the publication hereof.