



U74HCT14

CMOS IC

HIGH-SPEED CMOS LOGIC HEX INVERTING SCHMITT TRIGGER

DESCRIPTION

The UTC **U74HCT14** each contain six inverting schmitt triggers in one package. Each of them perform the Boolean function $\bar{Y} = A$

FEATURES

- * Widely range of input rise and fall time
- * high noise immunity
- * Fan-out parameters(over temperature range) up to 10 LSTTL Loads
- * Low power consumption
- * Wide range operation 4.5V ~ 5.5V

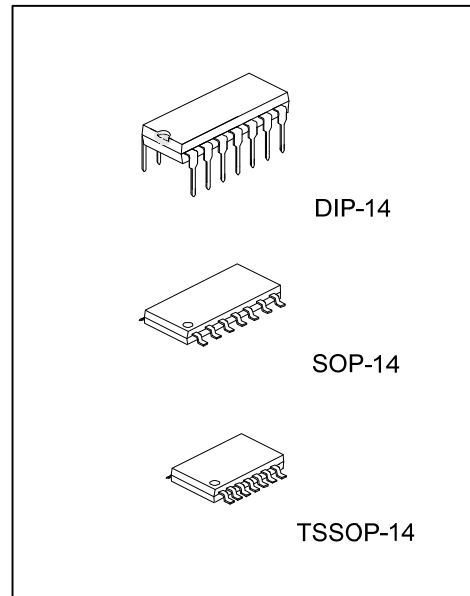

ORDERING INFORMATION

Ordering Number		Package	Packing
Lead Free	Halogen Free		
U74HCT14L-D14-T	U74HCT14G-D14-T	DIP-14	Tube
U74HCT14L-S14-R	U74HCT14G-S14-R	SOP-14	Tape Reel
U74HCT14L-P14-R	U74HCT14G-P14-R	TSSOP-14	Tape Reel

<p>U74HCT14G-D14-T</p> <ul style="list-style-type: none"> (1) Packing Type (2) Package Type (3) Green Package 	<p>(1) R: Tape Reel, T: Tube</p> <p>(2) D14: DIP-14, S14: SOP-14, P14: TSSOP-14</p> <p>(3) G: Halogen Free and Lead Free, L: Lead Free</p>
--	--

MARKING

DIP-14	SOP-14 / TSSOP-14
<p>Date Code</p> <p>L: Lead Free</p> <p>G: Halogen Free</p> <p>Lot Code</p>	<p>Date Code</p> <p>L: Lead Free</p> <p>G: Halogen Free</p> <p>Lot Code</p>

■ PIN CONFIGURATION

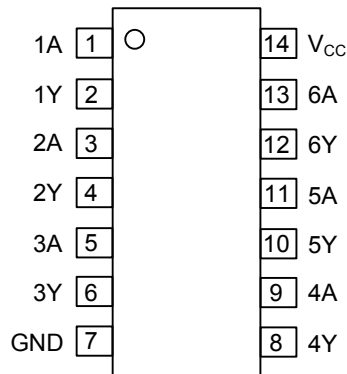

■ FUNCTIONAL DIAGRAM

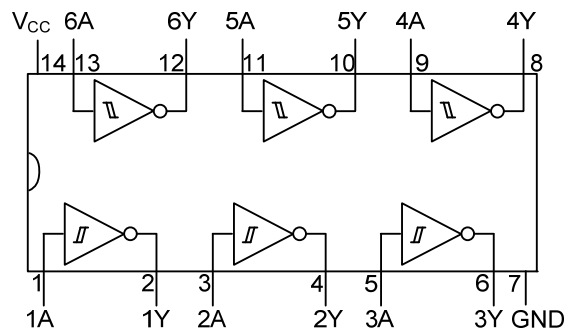

■ TRUTH TABLE

INPUT(A)	OUTPUT(Y)
L	H
H	L

Note: H=High level, L=Low Level

FLYING 汎翔國際有限公司
www.flying1688.com

■ LOGIC DIAGRAM

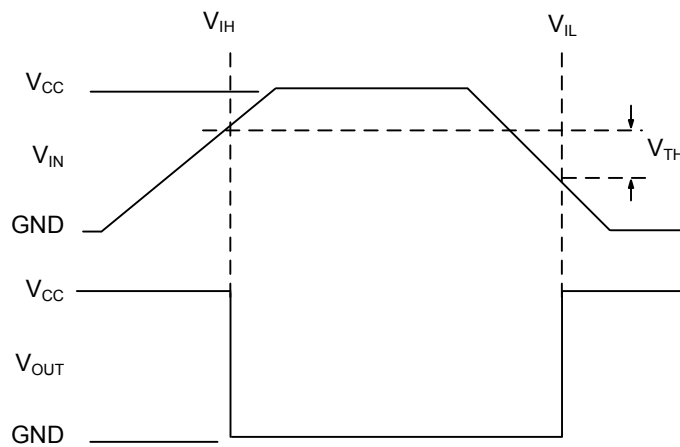
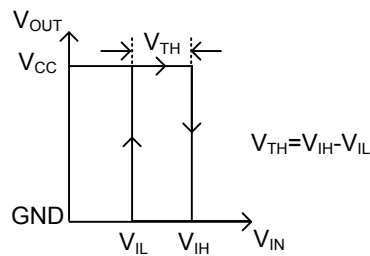
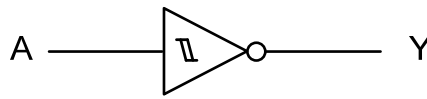

Hysteresis Definition, Characteristic, And Test Setup

FLYING 汎翔國際有限公司
www.flying1688.com

■ ABSOLUTE MAXIMUM RATINGS

PARAMETER		SYMBOL	RATINGS	UNIT
DC Supply Voltage		V_{CC}	-0.5V~7V	V
Input Clamp Current	For $V_{IN} < 0$ or $V_{IN} > V_{CC}$	I_{IK}	± 20	mA
Output Clamp Current	For $V_{OUT} < 0$ or $V_{OUT} > V_{CC}$	I_{OK}	± 20	mA
Continuous Output Current	For $V_{OUT} = 0$ to V_{CC}	I_{OUT}	± 25	mA
V_{CC} or Ground Current		I_{CC}	± 50	mA
Operating Supply Voltage Range		V_{CC}	4.5~5.5	V
Operating DC Input or Output Voltage		V_{IN}, V_{OUT}	0V~ V_{CC}	V
Operating Temperature		T_{OPR}	-40 ~ +85	$^{\circ}C$
Storage Temperature		T_{STG}	-65 ~ +150	$^{\circ}C$

Note: Absolute maximum ratings are those values beyond which the device could be permanently damaged. Absolute maximum ratings are stress ratings only and functional device operation is not implied.

■ THERMAL DATA

PARAMETER		SYMBOL	RATINGS	UNIT
Thermal Resistance Junction Ambient	DIP-14	θ_{JA}	80	$^{\circ}C/W$
	SOP-14		86	$^{\circ}C/W$
	TSSOP-14		113	$^{\circ}C/W$

■ RECOMMENDED OPERATING CONDITIONS

PARAMETER	SYMBOL	CONDITIONS	MIN	TYP	MAX	UNIT
Supply Voltage Range HC Types	V_{CC}		4.5		5.5	V
Input or Output Voltage	V_{IN}, V_{OUT}		0		V_{CC}	V
Operating Temperature	T_A		-40		85	$^{\circ}C$

■ ELECTRICAL CHARACTERISTICS

PARAMETER	SYMBOL	TEST CONDITIONS	MIN	TYP	MAX	UNIT
High-Level Input Voltage	V_{IH}	$V_{CC}=4.5V$	1.2	1.5	1.9	V
		$V_{CC}=5.5V$	1.4	1.7	2.1	V
Low-Level Input Voltage	V_{IL}	$V_{CC}=4.5V$	0.5	0.9	1.2	V
		$V_{CC}=5.5V$	0.6	1	1.4	V
Hysteresis	V_{TH}	$V_{CC}=4.5V$	0.4	0.6	1.4	V
		$V_{CC}=5.5V$	0.4	0.65	1.5	V
High Level Output Voltage CMOS Loads	V_{OH}	$V_{CC}=4.5V, V_{IN}=V_{IH}$ or $V_{IL}, I_{OH}=-20\mu A$	4.4	4.49		V
High Level Output Voltage TTL Loads		$V_{CC}=4.5V, V_{IN}=V_{IH}$ or $V_{IL}, I_{OH}=-4mA$	3.98			V
Low Level Output Voltage CMOS Loads	V_{OL}	$V_{CC}=4.5V, V_{IN}=V_{IH}$ or $V_{IL}, I_{OL}=20\mu A$			0.1	V
Low Level Output Voltage TTL Loads		$V_{CC}=4.5V, V_{IN}=V_{IH}$ or $V_{IL}, I_{OL}=4mA$			0.26	V
Input Leakage Current	I_{IN}	$V_{CC}=5.5V, V_{IN}=V_{CC}$ and GND			± 0.1	μA
Quiescent Device Current	I_Q	$V_{IN}=V_{CC}$ or GND, $I_{OUT}=0mA$			2	μA
Additional Quiescent Device	ΔI_Q (Note)	One input at 0.5V or 2.4V, Other inputs at GND or V_{CC}			2.4	mA
SWITCHING SPECIFICATIONS (Input $t_R, t_F = 6ns$)						
Propagation Delay, A to Y	t_{PLH}, t_{PHL}	$V_{CC}=4.5V, C_L=50pF$			32	ns
		$V_{CC}=5.5V, C_L=50pF$			30	ns
Output Transition Times	t_{TLH}, t_{THL}	$V_{CC}=4.5V, C_L=50pF$			15	ns
		$V_{CC}=5.5V, C_L=50pF$			14	ns
Input Capacitance	C_{IN}			3	10	pF
Power Dissipation Capacitance	C_{pd}	No load		10		pF

Note: This is the increase in supply current for each input that is at one of the specified TTL voltage levels, rather than 0 V or V_{CC} .

■ TEST WAVEFORM

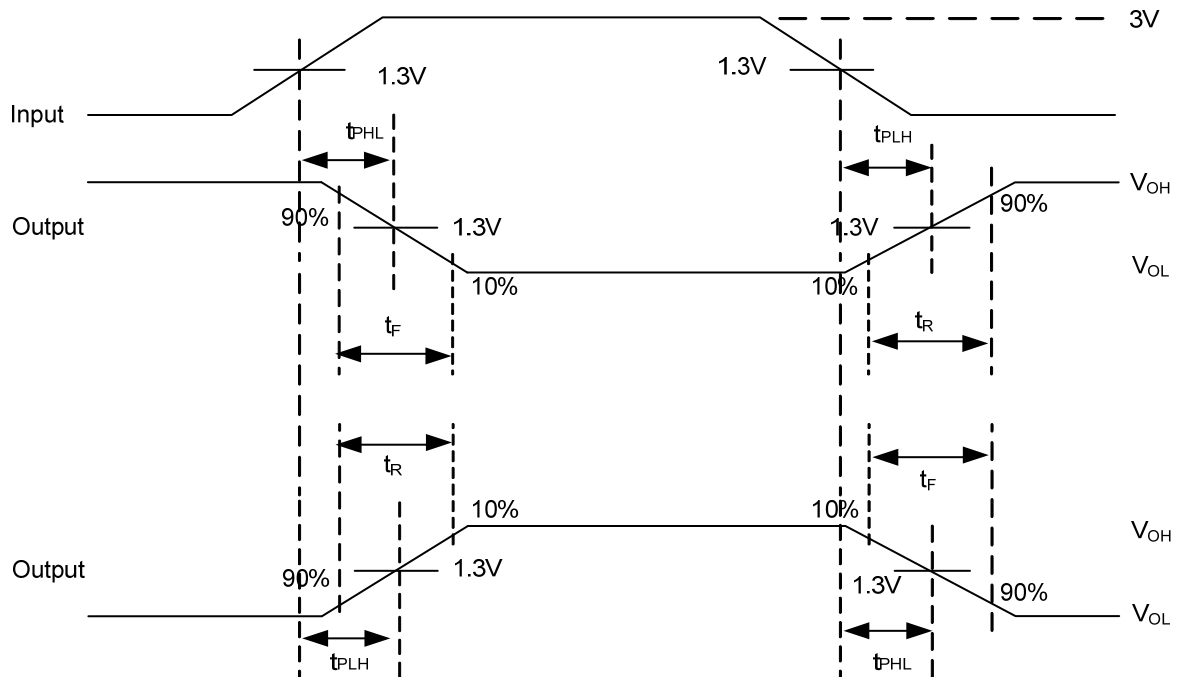

UTC assumes no responsibility for equipment failures that result from using products at values that exceed, even momentarily, rated values (such as maximum ratings, operating condition ranges, or other parameters) listed in products specifications of any and all UTC products described or contained herein. UTC products are not designed for use in life support appliances, devices or systems where malfunction of these products can be reasonably expected to result in personal injury. Reproduction in whole or in part is prohibited without the prior written consent of the copyright owner. UTC reserves the right to make changes to information published in this document, including without limitation specifications and product descriptions, at any time and without notice. This document supersedes and replaces all information supplied prior to the publication hereof.