



U74HCT3G34

CMOS IC

TRIPLE BUFFER GATE

DESCRIPTION

The **U74HCT3G34** provides three buffers, it is compatible with TTL.

FEATURES

- * Low power dissipation
- * High speed
- * High noise immunity

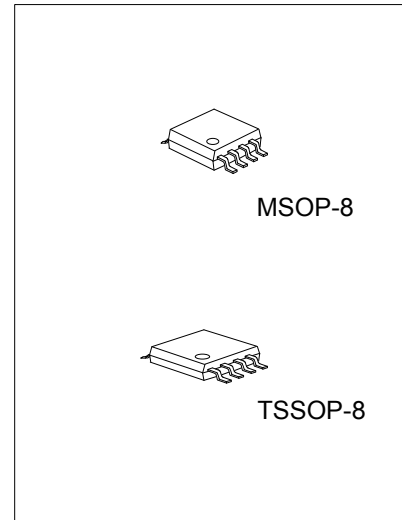

ORDERING INFORMATION

Ordering Number		Package	Packing
Lead Free	Halogen Free		
U74HCT3G34L-SM1-R	U74HCT3G34G-SM1-R	MSOP-8	Tape Reel
U74HCT3G34L-P08-R	U74HCT3G34G-P08-R	TSSOP-8	Tape Reel

<p>U74HCT3G34G-SM1-R</p> <p>(1) Packing Type (2) Package Type (3) Green Package</p>	<p>(1) R: Tape Reel (2) SM1: MSOP-8, P08: TSSOP-8 (3) G: Halogen Free and Lead Free, L: Lead Free</p>
---	---

MARKING

MSOP-8	TSSOP-8
<p>8 7 6 5 → Date Code UTC □□□□ HCT3G34 □ □ □ → Lot Code 1 2 3 4</p> <p>L: Lead Free G: Halogen Free</p>	<p>8 → Date Code 1 UTC □□□□ 2 3G34 □ 7 3 □ 6 → Lot Code 4 □ 5</p> <p>L: Lead Free G: Halogen Free</p>



■ PIN CONFIGURATION

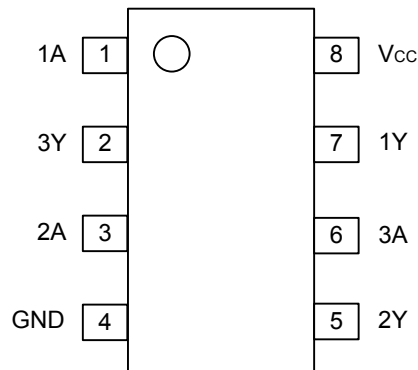

■ FUNCTION TABLE (each gate)

INPUT	OUTPUT
A	Y
L	L
H	H

■ LOGIC DIAGRAM (positive logic)

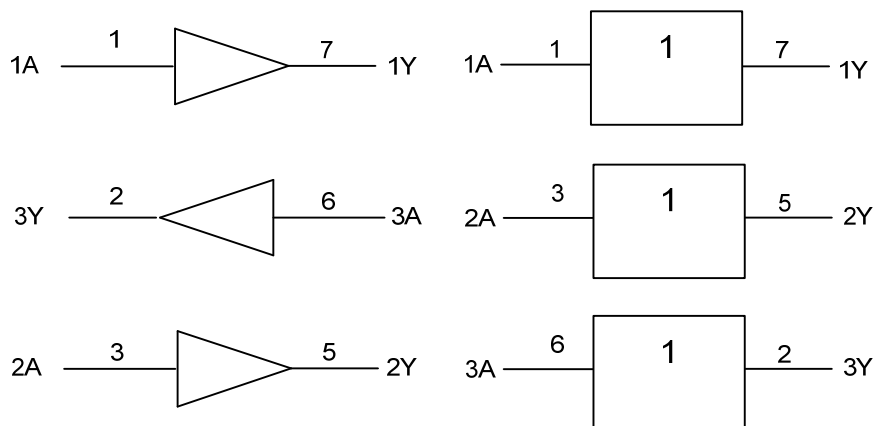

FLYING 汎翔國際有限公司
www.flying1688.com

■ ABSOLUTE MAXIMUM RATINGS (unless otherwise specified)

PARAMETER	SYMBOL	RATINGS	UNIT
Supply Voltage	V _{CC}	-0.5~7	V
Output Voltage	V _{OUT}	-0.5~V _{CC} +0.5	V
Output Current	I _{OUT}	25	mA
V _{CC} or GND Current	I _{CC}	50	mA
Input Clamp Current	I _{IK}	±20	mA
Output Clamp Current	I _{OK}	±20	mA
Power Dissipation	P _D	300	mW
Storage Temperature	T _{STG}	-65 ~ +150	°C

Note: Absolute maximum ratings are those values beyond which the device could be permanently damaged.

Absolute maximum ratings are stress ratings only and functional device operation is not implied.

■ RECOMMENDED OPERATING CONDITIONS

PARAMETER	SYMBOL	CONDITIONS	MIN	TYP	MAX	UNIT
Supply Voltage	V _{CC}		4.5	5.0	5.5	V
Input Voltage	V _{IN}		0		V _{CC}	V
Output Voltage	V _{OUT}		0		V _{CC}	V
Input Rise and Fall Times	t _R , t _F	V _{CC} =4.5V		6.0	500	ns
Operating Temperature	T _A		-40		+125	°C

■ STATIC CHARACTERISTICS (T_A=25°C)

PARAMETER	SYMBOL	TEST CONDITIONS	MIN	TYP	MAX	UNIT
High-Level Input Voltage	V _{IH}	V _{CC} =4.5V~5.5V	2.0	1.6		V
Low-Level Input Voltage	V _{IL}	V _{CC} =4.5V~5.5V		1.2	0.8	V
High-Level Output Voltage	V _{OH}	V _{CC} =4.5V, I _{OH} =-20μA	4.4	4.5		V
		V _{CC} =4.5V, I _{OH} =-4.0mA	4.13	4.32		V
Low-Level Output Voltage	V _{OL}	V _{CC} =4.5V, I _{OL} =20μA		0	0.1	V
		V _{CC} =4.5V, I _{OL} =4.0mA		0.15	0.33	V
Input Leakage Current	I _{I(LEAK)}	V _{CC} =5.5V, V _{IN} =V _{CC} or GND			±1.0	μA
Quiescent Supply Current	I _Q	V _{CC} =5.5V, I _{OUT} =0, V _{IN} =V _{CC} or GND			10	μA
Additional Quiescent Supply Current	Δ I _Q	V _{CC} =5.5V, V _{IN} =V _{CC} -2.1V; I _{OUT} =0			375	μA
Input Capacitance	C _{IN}			1.5		pF

■ DYNAMIC CHARACTERISTICS (T_A=25°C, t_R, t_F≤6.0ns)

PARAMETER	SYMBOL	TEST CONDITIONS	MIN	TYP	MAX	UNIT
Propagation Delay From nA to nY	t _{PHL} /t _{PLH}	V _{CC} =4.5V, C _L =50 pF		10	23	ns
Output Transition Time	t _{THL} /t _{TLH}	V _{CC} =4.5V, C _L =50 pF		6	19	ns

■ OPERATING CHARACTERISTICS

PARAMETER	SYMBOL	TEST CONDITION	MIN	TYP	MAX	UNIT
Power Dissipation Capacitance per Gate	C _{pd}			9		pF

■ T TEST CIRCUIT AND WAVEFORMS

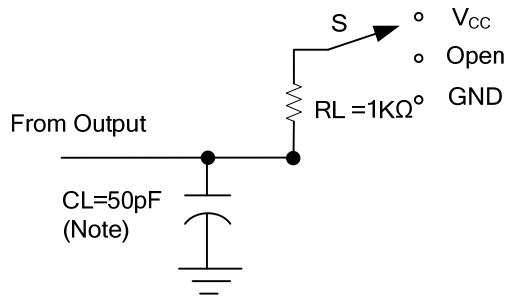

TEST	S
t_{PLH}/t_{PHL}	Open
t_{PHZ}/t_{PZH}	GND
t_{PLZ}/t_{PZL}	V_{CC}

Note: C_L includes probe and jig capacitance.

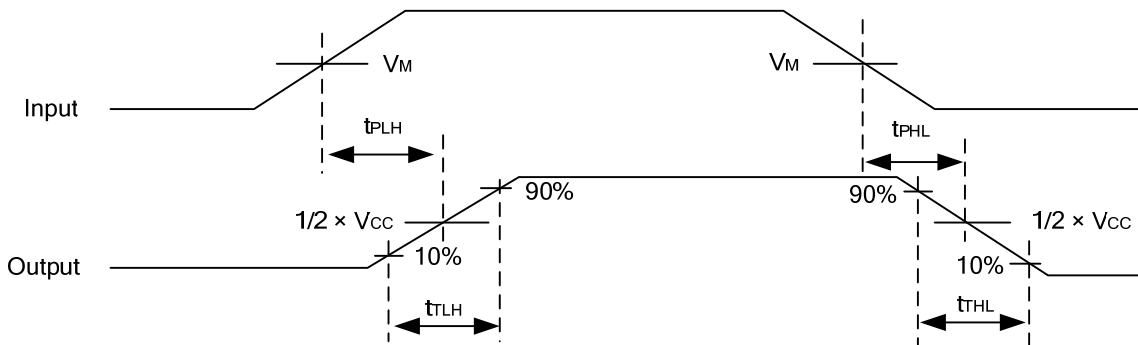

$V_M=1.3V, Input=GND \text{ to } 3.0V$

UTC assumes no responsibility for equipment failures that result from using products at values that exceed, even momentarily, rated values (such as maximum ratings, operating condition ranges, or other parameters) listed in products specifications of any and all UTC products described or contained herein. UTC products are not designed for use in life support appliances, devices or systems where malfunction of these products can be reasonably expected to result in personal injury. Reproduction in whole or in part is prohibited without the prior written consent of the copyright owner. UTC reserves the right to make changes to information published in this document, including without limitation specifications and product descriptions, at any time and without notice. This document supersedes and replaces all information supplied prior to the publication hereof.