



U74HCT4040

CMOS IC

12-BIT ASYNCHRONOUS BINARY COUNTERS

DESCRIPTION

The **U74HC4040** is a 12-stage asynchronous binary counter with a clock input (CLK), an overriding asynchronous master reset input (CLR) and twelve parallel outputs (Q0 to Q11). The counter advances on the High to Low transition of CLK. A HIGH on CLR clears all counter stages and forces all outputs Low, independent of the state of CLK. Each counter stage is a static toggle flip-flop. Inputs include clamp diodes that enable the use of current limiting resistors to interface inputs to voltages in excess of V_{CC} .

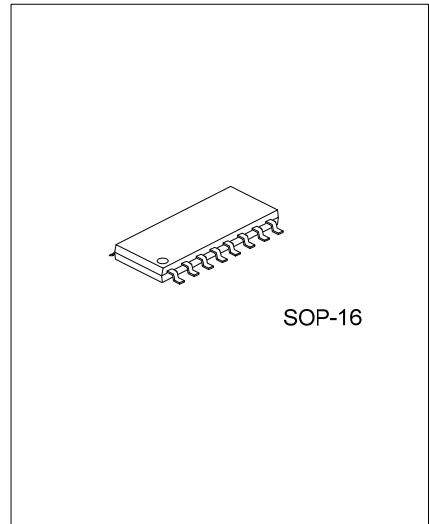

FEATURES

- * Wide Operating Voltage Range of 4.5V to 5.5V
- * Low Power Consumption, 8 μ A Maximum I_{CC}
- * ± 4 mA Output Drive at 5V

ORDERING INFORMATION

Ordering Number		Package	Packing
Lead Free	Halogen Free		
U74HCT4040L-S16-R	U74HCT4040G-S16-R	SOP-16	Tape Reel

<p>U74HCT4040G-S16-R</p> <ul style="list-style-type: none"> (1) Packing Type (2) Package Type (3) Green Package 	<ul style="list-style-type: none"> (1) R: Tape Reel (2) S16: SOP-16 (3) G: Halogen Free and Lead Free, L: Lead Free
--	--

MARKING

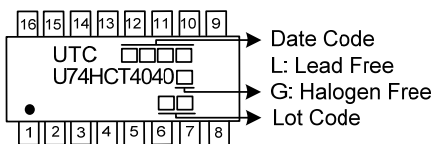

■ PIN CONFIGURATION

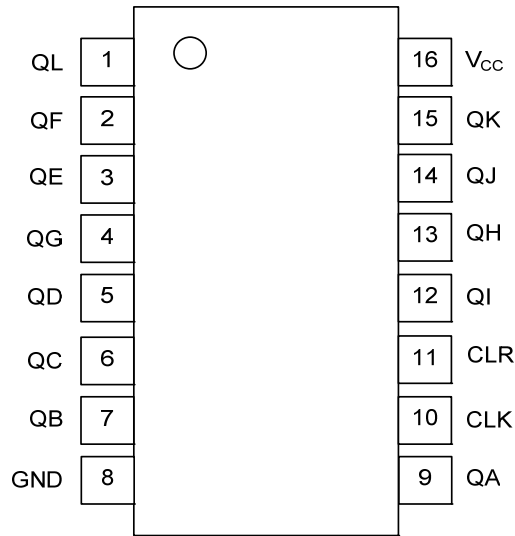

■ FUNCTION TABLE

INPUTS		FUNCTION
CLK	CLR	Q0 to Q11
↑	L	No Change
↓	L	Advance to next stage
X	H	All Outputs L

Note: H = HIGH voltage level, L = LOW voltage level, X = don't care
 ↑ = LOW-to-HIGH clock transition, ↓ = HIGH-to-LOW clock transition.

■ LOGIC DIAGRAM (positive logic)

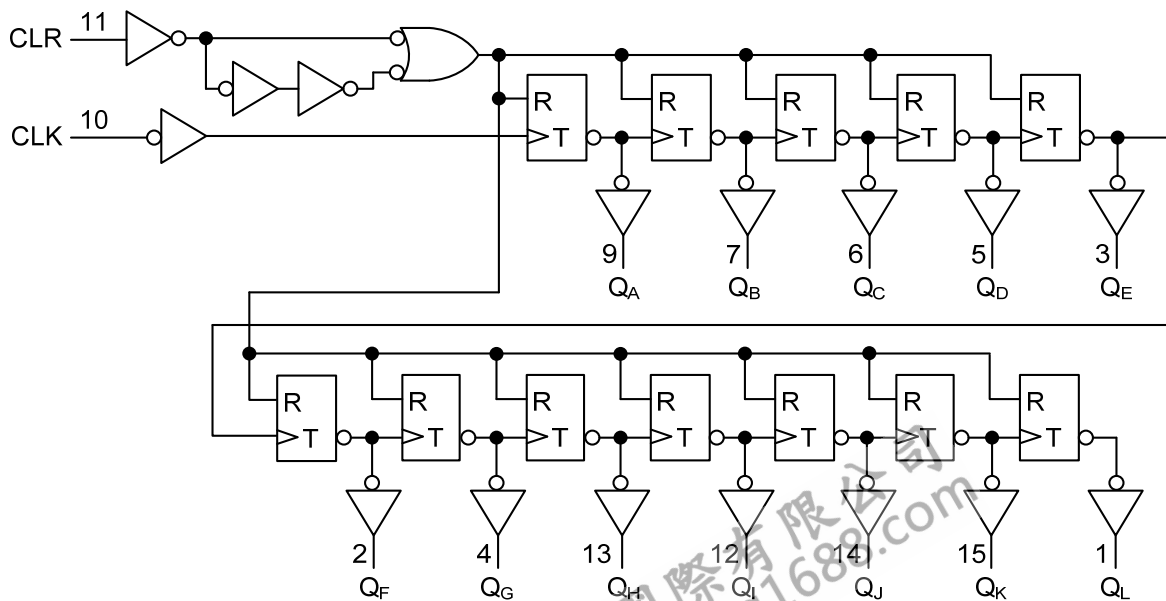

■ TIMING DIAGRAM

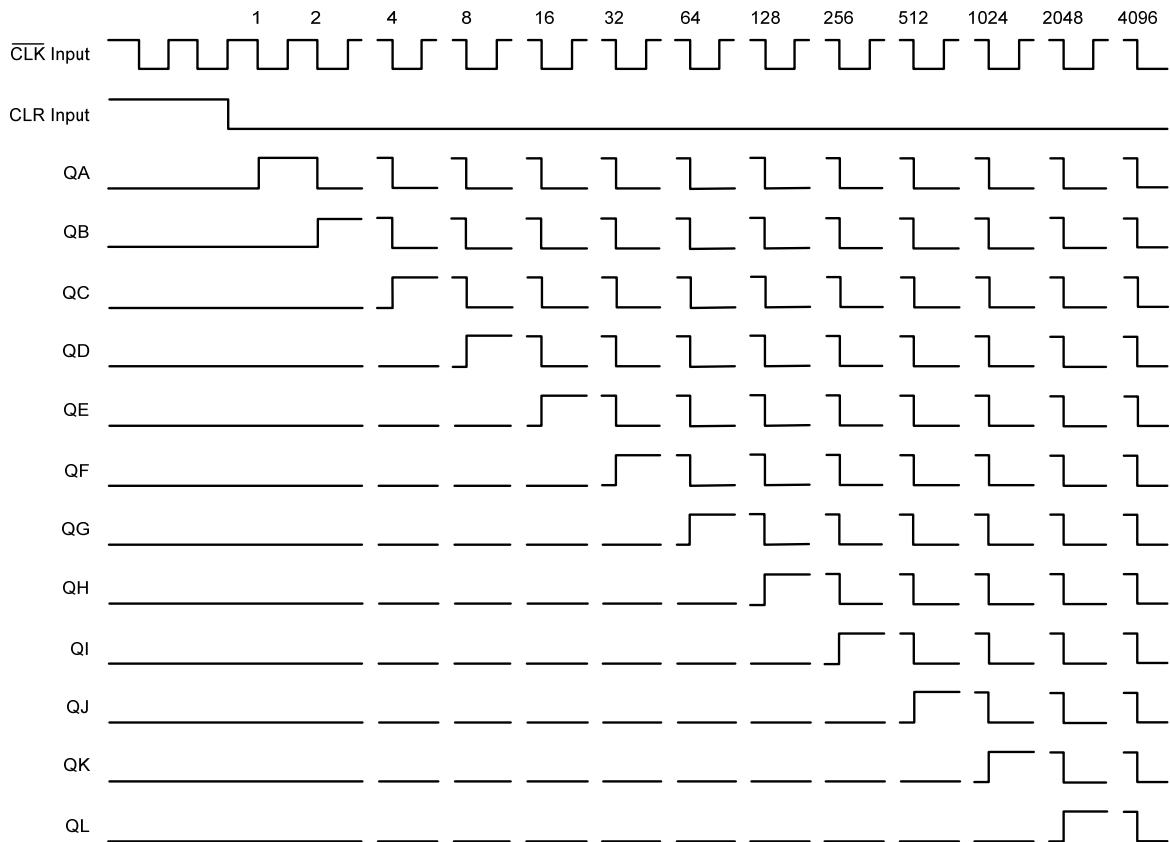

FLYING 汎翔國際有限公司
www.flying1688.com

■ ABSOLUTE MAXIMUM RATING (Note 2)

PARAMETER	SYMBOL	TEST CONDITIONS	RATINGS	UNIT
Supply Voltage	V_{CC}		-0.5 ~ +7.0	V
Input Voltage	V_{IN}		-0.5 ~ $V_{CC}+0.5$	V
Output Voltage	V_{OUT}	Active Mode	-0.5 ~ $V_{CC}+0.5$	V
Continuous V_{CC} or GND Current	I_{CC}		±50	mA
Continuous Output Current	I_{OUT}	$V_{OUT}=0V \sim V_{CC}$	±25	mA
Input Clamp Current	I_{IK}	$V_{IN}<0V$ or $V_{IN}>V_{CC}$	±20	mA
Output Clamp Current	I_{OK}	$V_{OUT}>V_{CC}$ or $V_{OUT}<0V$	±20	mA
Storage Temperature Range	T_{STG}		-65 ~ +150	°C

Notes: 1. Absolute maximum ratings are those values beyond which the device could be permanently damaged.

Absolute maximum ratings are stress ratings only and functional device operation is not implied.

2. The input and output voltage ratings may be exceeded if the input and output current ratings are observed.

■ RECOMMENDED OPERATING CONDITIONS

PARAMETER	SYMBOL	TEST CONDITIONS	MIN	TYP	MAX	UNIT
Supply Voltage	V_{CC}		4.5	5.0	5.5	V
Input Voltage	V_{IN}		0		V_{CC}	V
Output Voltage	V_{OUT}		0		V_{CC}	V
Operating Temperature	T_A		-40		+85	°C
Input Transition Rise or Fall Rate	$\Delta t/\Delta v$	$V_{CC}=4.5V$			500	ns

■ ELECTRICAL CHARACTERISTICS ($T_A = 25^\circ C$, unless otherwise specified)

PARAMETER	SYMBOL	TEST CONDITIONS	MIN	TYP	MAX	UNIT
High-level Input Voltage	V_{IH}	$V_{CC}=4.5V \sim 5.5V$	2.0			V
Low-level Input Voltage	V_{IL}	$V_{CC}=4.5V \sim 5.5V$			0.8	V
High-Level Output Voltage	V_{OH}	$V_{IN}=V_{IH}$ or V_{IL} , $V_{CC}=4.5V$	$I_{OH}=-20\mu A$	4.4		V
			$I_{OH}=-4.0mA$	3.98		V
Low-Level Output Voltage	V_{OL}	$V_{IN}=V_{IH}$ or V_{IL} , $V_{CC}=4.5V$	$I_{OL}=20\mu A$		0.1	V
			$I_{OL}=4.0mA$		0.26	V
Input Leakage Current	$I_{I(LEAK)}$	$V_{CC}=5.5V$, $V_{IN}=V_{CC}$ or GND		±0.01	±0.1	μA
Quiescent Supply Current	I_{CC}	$V_{CC}=5.5V$, $V_{IN}=V_{CC}$ or GND, $I_{OUT}=0A$			8	μA
Additional Quiescent Device Current Per Input Pin	ΔI_{CC}	$V_{CC}=4.5V \sim 5.5V$, $I_{OUT}=0A$ One input= $V_{CC}-2.1V$, other inputs at V_{CC} or GND			360	μA
Input Capacitance	C_I	$V_{CC}=4.5V \sim 5.5V$, $V_{IN}=V_{CC}$ or GND		3.5		pF

■ SWITCHING CHARACTERISTICS ($T_A = 25^\circ\text{C}$, $t_R, t_F \leq 6\text{nS}$, unless otherwise specified)

PARAMETER	SYMBOL	TEST CONDITIONS	MIN	TYP	MAX	UNIT
Maximum Clock Pulse Frequency From Input (CLK)	f_{MAX}	$V_{\text{CC}}=5\text{V}, C_L=15\text{pF}$	25			MHz
Propagation Delay From Input (CLK) to Output (Q0)	t_{PHL}	$V_{\text{CC}}=4.5\text{V}, C_L=50\text{pF}$		19	40	ns
	t_{PLH}	$V_{\text{CC}}=5.0\text{V}, C_L=15\text{pF}$		17		
Propagation Delay From Input (Qn) to Output (Qn+1)	t_{PHL}	$V_{\text{CC}}=4.5\text{V}, C_L=50\text{pF}$		10	20	ns
	t_{PLH}	$V_{\text{CC}}=5.0\text{V}, C_L=15\text{pF}$		8		
Propagation Delay From Input (CLR) to Output (Qn)	t_{PHL}	$V_{\text{CC}}=4.5\text{V}, C_L=50\text{pF}$		23	45	ns

■ TIMING REQUIREMENTS (Input: $t_R, t_F \leq 6\text{nS}$; $\text{PRR} \leq 1\text{MHz}$)

PARAMETER	SYMBOL	TEST CONDITIONS	MIN	TYP	MAX	UNIT
Clock Pulse Width High or Low (CLK)	t_w	$V_{\text{CC}}=4.5\text{V}, C_L=50\text{pF}$	16	7		ns
Reset Pulse Width High (CLR)		$V_{\text{CC}}=4.5\text{V}, C_L=50\text{pF}$	16	6		ns
Recovery Time (CLR) to (CLK)	t_{SU}	$V_{\text{CC}}=4.5\text{V}, C_L=50\text{pF}$	10	2		ns

■ OPERATING CHARACTERISTICS ($T_A = 25^\circ\text{C}$, unless otherwise specified)

PARAMETER	SYMBOL	TEST CONDITIONS	MIN	TYP	MAX	UNIT
Power Dissipation Capacitance	C_{PD}			20		pF

FLYING 汎翔國際有限公司
 www.flying1688.com

TEST CIRCUIT AND WAVEFORMS

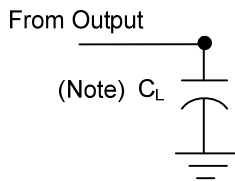

Note: C_L includes probe and jig capacitance. $C_L=50\text{pF}$, $R_L=1\text{K}\Omega$.

INPUT		LOAD	TEST
V_{IN}	t_r, t_f	C_L	
V_{CC}	6.0ns	15pF, 50pF	t_{PLH}, t_{PHL}

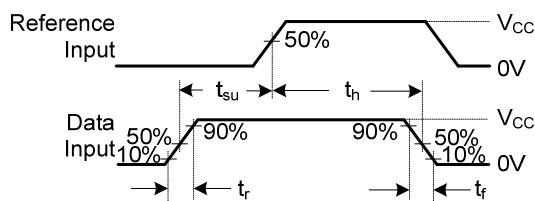

Voltage Waveforms Setup And Hold And Input Rise And Fall Times

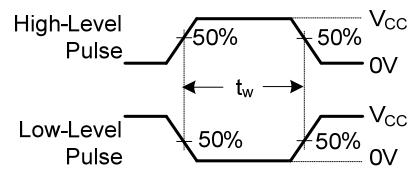

Voltage Waveforms Pulse Durations

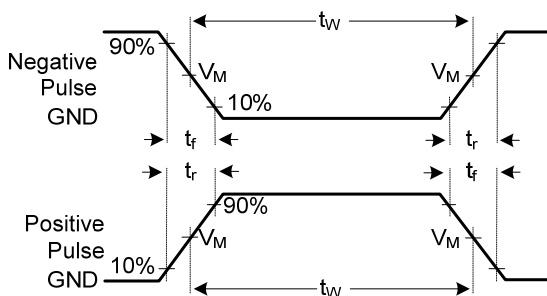

Test Circuit for Measuring Switching Times

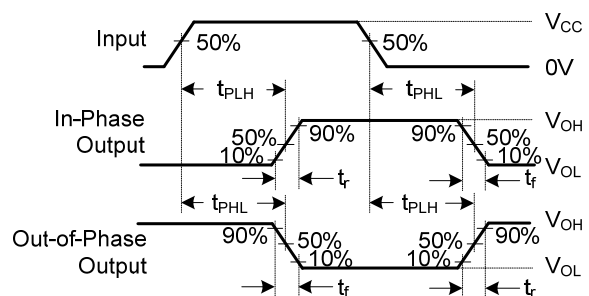

Voltage Waveforms Propagation Delay And Output Transition Times

- Notes: 1. C_L includes probe and jig capacitance.
 2. All input pulses are supplied by generators having the following characteristics: $\text{PRR} \leq 1\text{MHz}$, $Z_0 = 50\Omega$.

UTC assumes no responsibility for equipment failures that result from using products at values that exceed, even momentarily, rated values (such as maximum ratings, operating condition ranges, or other parameters) listed in products specifications of any and all UTC products described or contained herein. UTC products are not designed for use in life support appliances, devices or systems where malfunction of these products can be reasonably expected to result in personal injury. Reproduction in whole or in part is prohibited without the prior written consent of the copyright owner. UTC reserves the right to make changes to information published in this document, including without limitation specifications and product descriptions, at any time and without notice. This document supersedes and replaces all information supplied prior to the publication hereof.