



U74HCT595

CMOS IC

8-BIT SHIFT REGISTERS WITH LATCHED 3-STATE OUTPUT REGISTERS

DESCRIPTION

The UTC 74HCT595 contains an 8-bit register with asynchronous reset input and an 8-bit latch with output enable input. Data on the Serial Data Input (SER) will be shift into the internal shift register during every LOW-to-HIGH transition on the Shift Clock. The latch will latch the 8-bit data from the shift register during the LOW-to-HIGH transition on the Latch Clock. The shift register also provides a serial output.

FEATURES

- * Operation Voltage Range: 4.5V ~ 5.5V
- * High Noise Immunity
- * Output Compatibility with CMOS and TTL
- * 8-Bit Serial-In, Parallel-Out Shift
- * Inputs are TTL voltage compatible

ORDERING INFORMATION

Ordering Number		Package	Packing
Lead Free	Halogen Free		
U74HCT595L-S16-R	U74HCT595G-S16-R	SOP-16	Tape Reel
U74HCT595L-P16-R	U74HCT595G-P16-R	TSSOP-16	Tape Reel

<p>U74HCT595G-S16-R</p>	<p>(1) R: Tape Reel (2) S16: SOP-16, P16: TSSOP-16 (3) G: Halogen Free and Lead Free, L: Lead Free</p>
-------------------------	--

MARKING

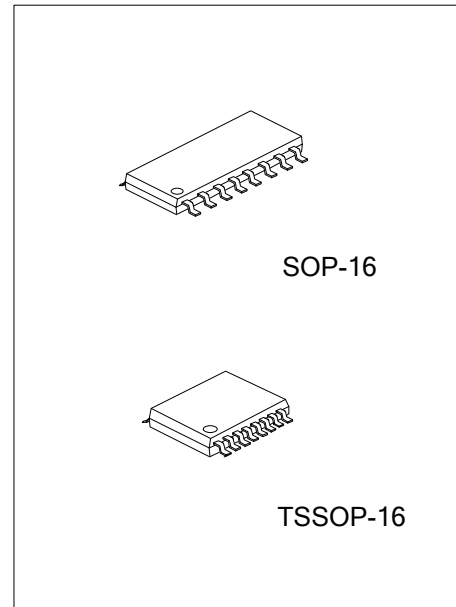
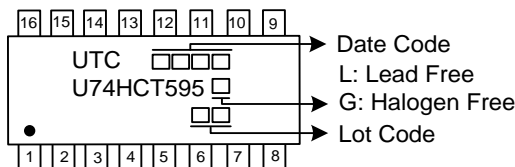

■ PIN CONFIGURATION

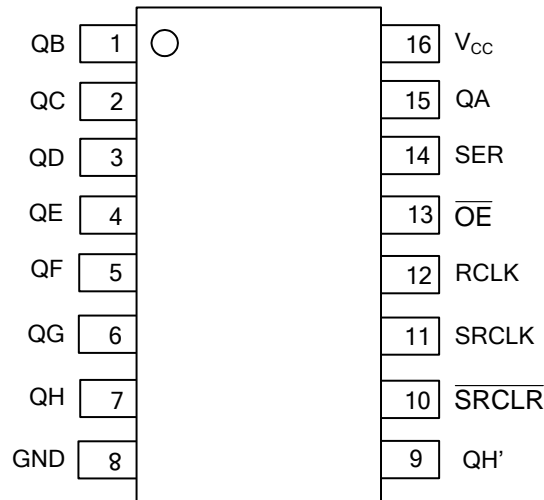

■ FUNCTION TABLE

FUNCTION	INPUTS					OUTPUTS	
	SRCLK	RCLK	\overline{OE}	\overline{SRCLR}	SER	QH'	Qn'
A Low-Level on \overline{SRCLR} only affects the shift registers.	X	X	L	L	X	L	NC
Empty shift register loaded into storage register.	X	↑	L	L	X	L	L
Shift register clear. Parallel outputs in high-impedance OFF-state	X	X	H	L	X	L	Z
Logic high level shifted into the first shift register. Contents of all shift register stages shifted through, e.g. previous state of stage G(internal QG') appears on the serial output(QH').	↑	X	L	H	H	QG'	NC
Contents of shift register stages (internal Qn') are transferred to the storage register and parallel output stages.	X	↑	L	H	X	NC	Qn'
Contents of shift register shifted through. Previous contents of the shift register is transferred to the storage register and the parallel output stages.	↑	↑	L	H	X	QG'	Qn'

Note:H : HIGH voltage level.

L : LOW voltage level.

X : Don't care.

Z : High impedance OFF-state.

NC: No change.

↑ : Low-to-High transition.

↓ : High-to-Low transition.

■ LOGIC DIAGRAM

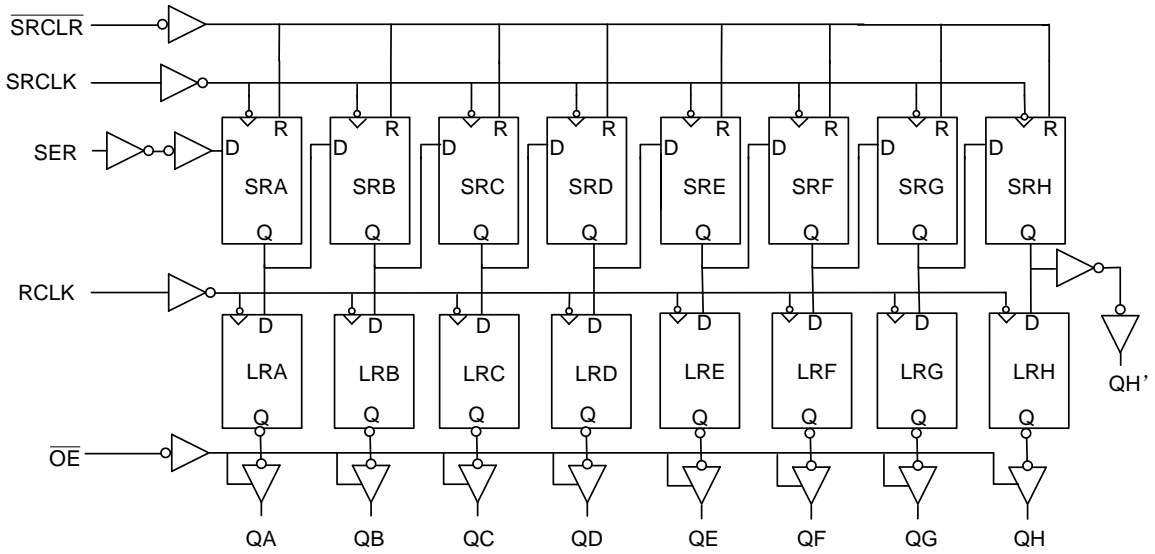

■ TIMING DIAGRAM

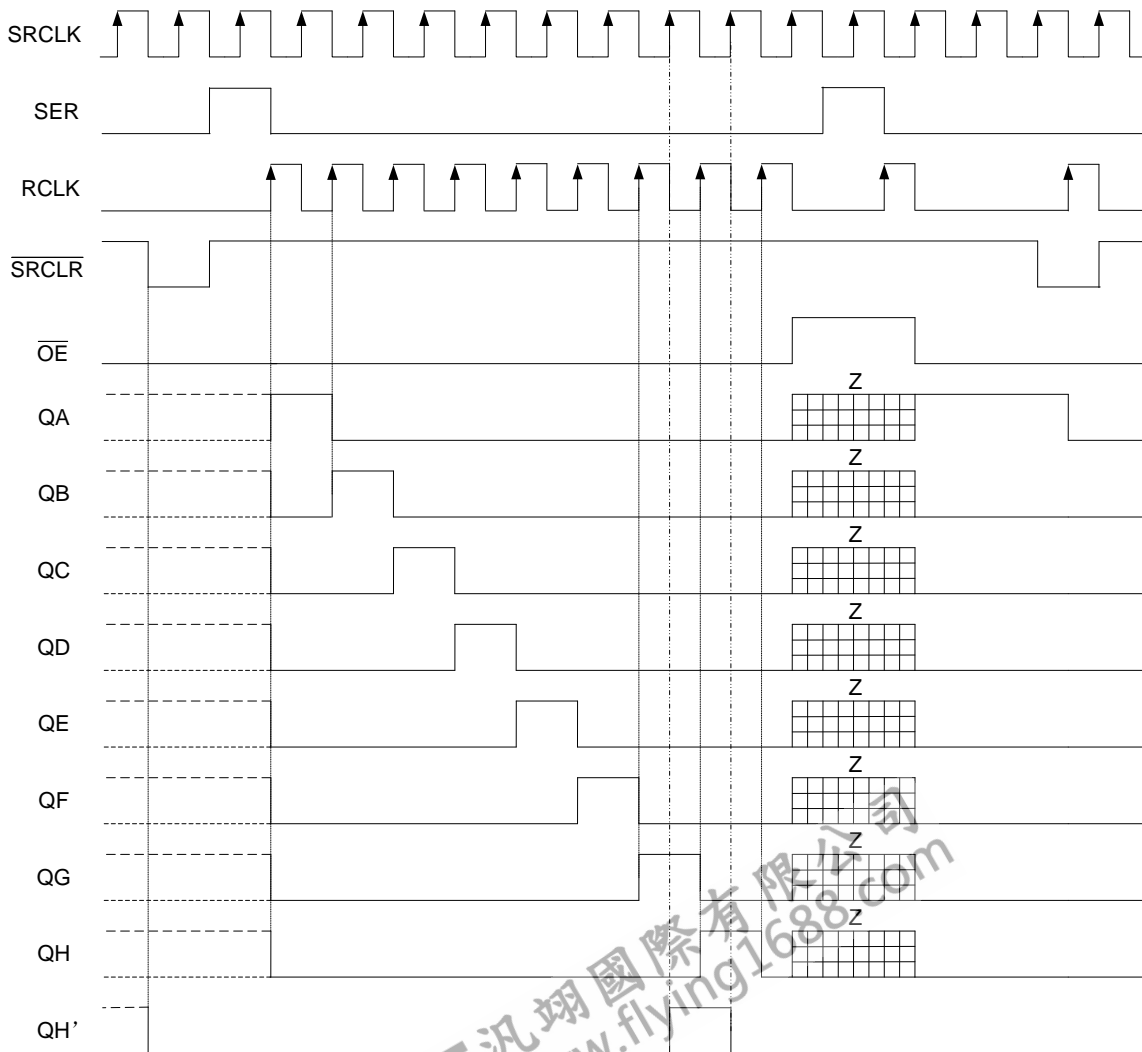

■ ABSOLUTE MAXIMUM RATING (unless otherwise specified)

PARAMETER	SYMBOL	RATINGS	UNIT
Supply Voltage	V_{CC}	-0.5 ~ 7.0	V
Input Voltage	V_{IN}	-0.5 ~ $V_{CC}+0.5$	V
Output Voltage(active mode)	V_{OUT}	-0.5 ~ $V_{CC}+0.5$	V
Input Clamp Current ($V_{IN} < 0$ or $V_{IN} > V_{CC}$)	I_{IK}	±20	mA
Output Clamp Current ($V_{OUT} < 0$ or $V_{OUT} > V_{CC}$)	I_{OK}	±20	mA
Output Current ($V_{OUT} = 0$ or V_{CC})	I_{OUT}	±35	mA
V_{CC} or GND Current	I_{CC}	±70	mA
Storage Temperature	T_{STG}	-65 ~ +150	°C

Notes: 1. Absolute maximum ratings are those values beyond which the device could be permanently damaged.

Absolute maximum ratings are stress ratings only and functional device operation is not implied.

2. The input and output voltage ratings may be exceeded if the input and output current ratings are observed.

■ RECOMMENDED OPERATING CONDITIONS

PARAMETER	SYMBOL	MIN	TYP	MAX	UNIT
Supply Voltage	V_{CC}	4.5	5	5.5	V
Input Voltage	V_{IN}	0		V_{CC}	V
Output Voltage	V_{OUT}	0		V_{CC}	V
Operating Temperature	T_{OPR}	-40		+85	°C
Input Transition Rise or Fall Rate	$V_{CC}=4.5V$ $\Delta t/\Delta v$		6.0	500	ns

■ ELECTRICAL CHARACTERISTICS ($T_A=25^\circ C$, unless otherwise specified)

PARAMETER	SYMBOL	TEST CONDITIONS	MIN	TYP	MAX	UNIT
High-Level input voltage	V_{IH}	$V_{CC}=4.5V\sim 5.5V$	2.0	1.6		V
Low-Level output voltage	V_{IL}	$V_{CC}=4.5V\sim 5.5V$		1.2	0.8	V
High-Level Output Voltage, QA-QH	V_{OH}	$V_{CC}=4.5V, I_{OH}=-20\mu A$	4.4	4.499		V
		$V_{CC}=4.5V, I_{OH}=-6mA$	3.98	4.3		V
Low-Level Output Voltage, QA-QH	V_{OL}	$V_{CC}=4.5V, I_{OL}=20\mu A$		0.001	0.1	V
		$V_{CC}=4.5V, I_{OL}=6mA$		0.17	0.26	V
High-Level Output Voltage, QH'	V_{OH}	$V_{CC}=4.5V, I_{OH}=-20\mu A$	4.4	4.499		V
		$V_{CC}=4.5V, I_{OH}=-4mA$	3.98	4.3		V
Low-Level Output Voltage, QH'	V_{OL}	$V_{CC}=4.5V, I_{OL}=20\mu A$		0.001	0.1	V
		$V_{CC}=4.5V, I_{OL}=4mA$		0.17	0.26	V
Input Leakage Current	$I_{I(LEAK)}$	$V_{CC}=5.5V, V_{IN}=V_{CC}$ or GND		±0.1	±100	nA
Output OFF -state current	I_{OZ}	$V_{CC}=5.5V, V_{OUT}=V_{CC}$ or GND		±0.01	±0.5	µA
Quiescent Supply Current	I_{CC}	$V_{CC}=5.5V, V_{IN}=V_{CC}$ or GND, $I_{OUT}=0$			8	µA
Additional Quiescent Supply Current	ΔI_{CC}	One input at $V_{CC}-2.1V$, other inputs at 0 or V_{CC}		100	450	uA
Input Capacitance	C_{IN}	$V_{CC}=5.5V, V_{IN}=V_{CC}$ or GND		3	10	pF

■ DYNAMIC CHARACTERISTICS (T_A=25°C, C_L=50pF, R_L=1kΩ, unless otherwise specified)

PARAMETER	SYMBOL	TEST CONDITIONS	MIN	TYP	MAX	UNIT
Maximum clock pulse frequency	f _{max}	V _{CC} =4.5V	30	52		MHz
Propagation delay from input RCLK to output Qn	t _{PHL} /t _{PLH}	V _{CC} =4.5V		24	40	ns
Propagation delay from input SRCLK to output QH'	t _{PLH} /t _{PHL}	V _{CC} =4.5V		24	42	ns
3-state output enable time from input \overline{OE} to output Qn	t _{PZH} /t _{PZL}	V _{CC} =4.5V		21	35	ns
3-state output disable time from input \overline{OE} to output Qn	t _{PHZ} /t _{PLZ}	V _{CC} =4.5V		18	30	ns
Propagation delay from input \overline{SRCLR} to output QH'	t _{PHL}	V _{CC} =4.5V		23	40	ns
Output transition time, QH'	t _{TLH} / t _{THL}	V _{CC} =4.5V		8	15	ns
Output transition time, Qn	t _{TLH} / t _{THL}	V _{CC} =4.5V		8	12	ns

■ TIMING REQUIREMENTS (T_A=25°C, unless otherwise specified)

PARAMETER	SYMBOL	TEST CONDITIONS	MIN	TYP	MAX	UNIT
Pulse duration, SRCLK high or low	t _w	V _{CC} =4.5V~5.5V	16	6		ns
Pulse duration, RCLK high or low		V _{CC} =4.5V~5.5V	16	5		ns
Pulse duration, \overline{SRCLR} low		V _{CC} =4.5V~5.5V	20	8		ns
Setup Time, SER before SRCLK↑	t _{SU}	V _{CC} =4.5V~5.5V	16	5		ns
Setup Time, SRCLK↑ before RCLK↑		V _{CC} =4.5V~5.5V	16	8		ns
Hold Time, SER after SRCLK↑	t _H	V _{CC} =4.5V~5.5V	3			ns

■ OPERATING CHARACTERISTICS

PARAMETER	SYMBOL	TEST CONDITIONS	MIN	TYP	MAX	UNIT
Power Dissipation Capacitance	C _{PD}	No Load		400		pF

TEST CIRCUIT AND WAVEFORMS

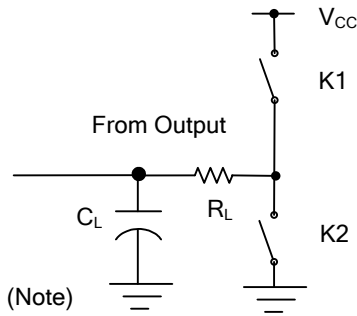

TEST	K1	K2
t_{PLH}/t_{PHL}	Open	Open
t_{PHZ}/t_{PZH}	Open	Close
t_{PLZ}/t_{PZL}	Close	Open

Note: C_L includes probe and jig capacitance.

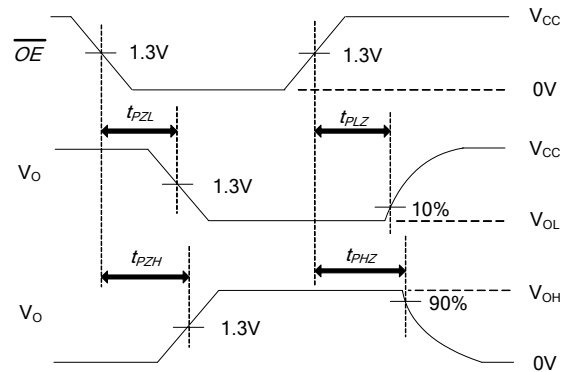
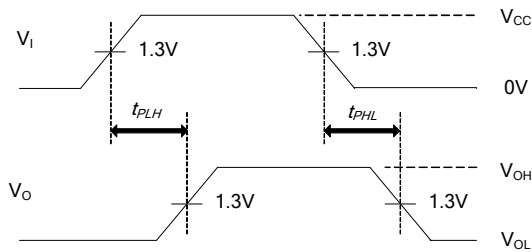
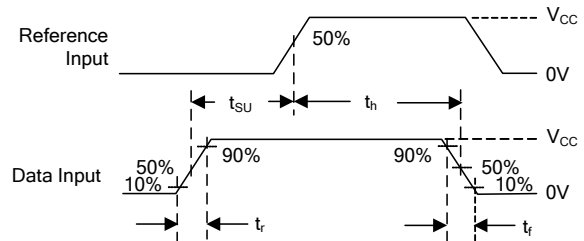
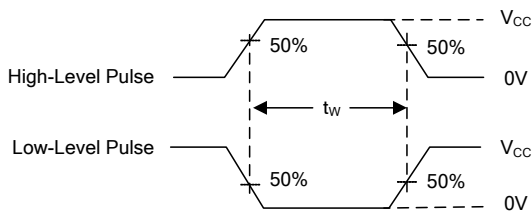

UTC assumes no responsibility for equipment failures that result from using products at values that exceed, even momentarily, rated values (such as maximum ratings, operating condition ranges, or other parameters) listed in products specifications of any and all UTC products described or contained herein. UTC products are not designed for use in life support appliances, devices or systems where malfunction of these products can be reasonably expected to result in personal injury. Reproduction in whole or in part is prohibited without the prior written consent of the copyright owner. UTC reserves the right to make changes to information published in this document, including without limitation specifications and product descriptions, at any time and without notice. This document supersedes and replaces all information supplied prior to the publication hereof.