



U74LV4052

CMOS IC

DUAL 4-CHANNEL ANALOG MULTIPLEXERS/DEMULTIPLEXERS

DESCRIPTION

These dual 4-channel CMOS analog multiplexers/demultiplexers are designed for 2-V to 5.5-V V_{CC} operation.

The **U74LV4052** handles both analog and digital signals. Each channel permits signals with amplitudes up to 5.5V (peak) to be transmitted in either direction.

Applications include signal gating, chopping, modulation or demodulation (modem), and signal multiplexing for analog-to-digital and digital-to-analog conversion systems.

FEATURES

- * 2-V to 5.5-V V_{CC} Operation
- * Fast Switching
- * High On-Off Output-Voltage Ratio
- * Low Crosstalk Between Switches
- * Extremely Low Input Current

ORDERING INFORMATION

Ordering Number		Package	Packing
Lead Free	Halogen Free		
U74LV4052L-S16-R	U74LV4052G-S16-R	SOP-16	Tape Reel
U74LV4052L-P16-R	U74LV4052G-P16-R	TSSOP-16	Tape Reel

U74LVC157G-S16-R	(1)Packing Type	(1) R: Tape Reel
	(2)Package Type	(2) S16: SOP-16, P16: TSSOP-16
	(3)Green Package	(3) G: Halogen Free and Lead Free, L: Lead Free

MARKING

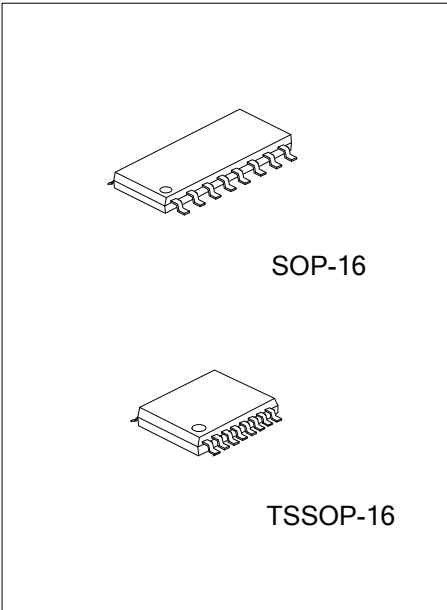
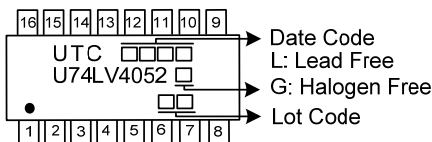

■ PIN CONFIGURATION

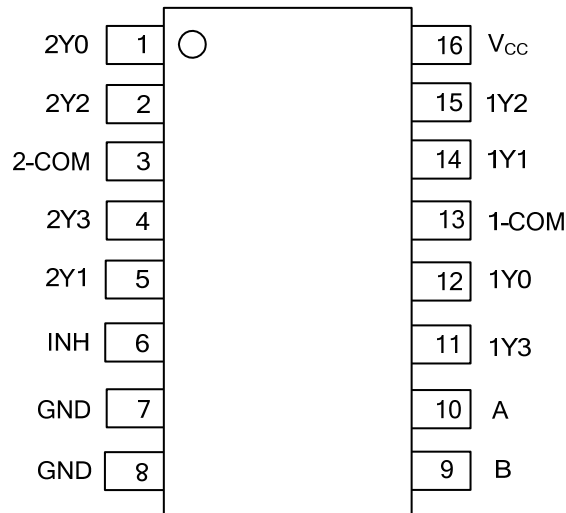

■ FUNCTION TABLE

INPUTS			ON Channel
INH	B	A	
L	L	L	1Y0, 2Y0
L	L	H	1Y1, 2Y1
L	H	L	1Y2, 2Y2
L	H	H	1Y3, 2Y3
H	X	X	None

Note: H: HIGH voltage level; L: LOW voltage level; X: Don't care

■ LOGIC DIAGRAM (positive logic)

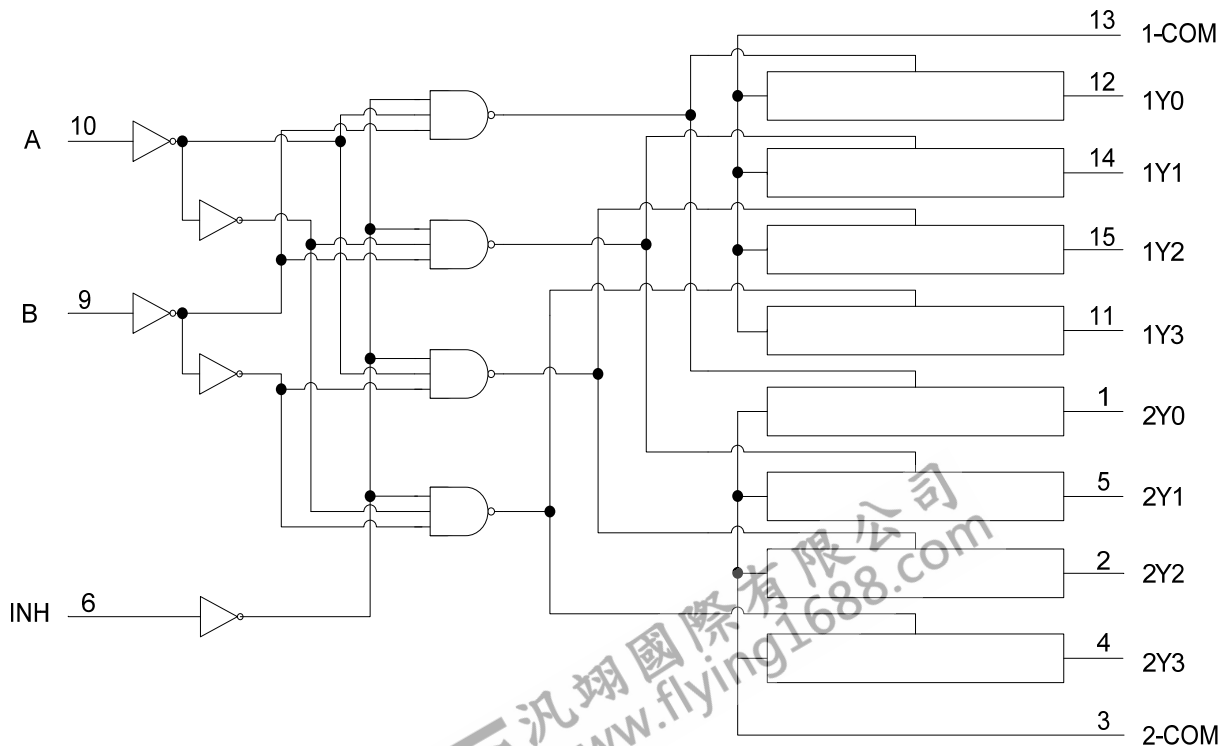

■ ABSOLUTE MAXIMUM RATING

PARAMETER	SYMBOL	RATINGS	UNIT
Supply voltage range	V_{CC}	-0.5 ~ +7.0	V
Input voltage range	V_{IN}	-0.5 ~ +7.0	V
Switch I/O voltage range	V_{IO}	-0.5~ V_{CC} +0.5	V
Input clamp current	I_{IK}	-20	mA
I/O diode Current	I_{IOK}	-50	mA
Switch through current	I_T	±25	mA
Continuous current through V_{CC} or GND	I_{CC}	±50	mA
Storage temperature range	T_{STG}	-65 ~ +150	°C

■ THERMAL DATA

PARAMETER	SYMBOL	RATINGS	UNIT
Junction to Ambient	SOP-16	73	°C/W
	TSSOP-16	108	°C/W

■ RECOMMENDED OPERATING CONDITIONS

PARAMETER	SYMBOL	TEST CONDITIONS	MIN	TYP	MAX	UNIT
Supply Voltage	V_{CC}		2.0		5.5	V
Control Input Voltage	V_{IN}		0		5.5	V
Input/output Voltage	V_{IO}		0		V_{CC}	V
Input Transition Rise or Fall rate	$\Delta t/\Delta v$	$V_{CC}=2.3V$ to $2.7V$			200	ns/V
		$V_{CC}=3V$ to $3.6V$			100	
		$V_{CC}=4.5V$ to $5.5V$			20	
Operating free-air temperature	T_A		-40		+85	°C

Note: All unused inputs of the device must be held at V_{CC} or GND to ensure proper device operation.

■ DC ELECTRICAL CHARACTERISTICS (T_A =25°C , unless otherwise specified)

PARAMETER	SYMBOL	TEST CONDITIONS	MIN	TYP	MAX	UNIT	
Input voltage	High-level	V _{CC} =2V	1.5			V	
		V _{CC} =2.3 ~ 2.7V	V _{CC} ×0.7				
		V _{CC} =3 ~ 3.6V	V _{CC} ×0.7				
		V _{CC} =4.5 ~ 5.5V	V _{CC} ×0.7				
	Low-level	V _{CC} =2V			0.5		
		V _{CC} =2.3 ~ 2.7V			V _{CC} ×0.3		
		V _{CC} =3 ~ 3.6V			V _{CC} ×0.3		
		V _{CC} =4.5 ~ 5.5V			V _{CC} ×0.3		
ON-state switch resistance	r _{ON}	V _{INH} =V _{IL} , V _I =V _{CC} or GND, I _T =2mA	V _{CC} =2.3V	43	180	Ω	
			V _{CC} =3V	34	150		
			V _{CC} =4.5V	25	75		
Peak ON-state resistance	r _{ON(p)}	V _{INH} =V _{IL} , V _I =V _{CC} or GND I _T =2mA	V _{CC} =2.3V	133	500	Ω	
			V _{CC} =3V	63	180		
			V _{CC} =4.5V	35	100		
Difference in on-state resistance between switches	Δr _{ON}	V _{INH} =V _{IL} , V _I =V _{CC} or GND I _T =2mA	V _{CC} =2.3V	1.5	30	Ω	
			V _{CC} =3V	1.1	20		
			V _{CC} =4.5V	0.7	15		
Off-state switch leakage current	I _{S(off)}	V _I =V _{CC} and V _O =GND, or V _I =GND and V _O =V _{CC} , V _{INH} =V _{IH}	V _{CC} =5.5V		±0.1	μA	
On-state switch leakage current	I _{S(on)}	V _{INH} =V _{IL} , V _I =V _{CC} or GND	V _{CC} =5.5V		±0.1	μA	
Supply Current	I _{CC}	V _I =V _{CC} or GND	V _{CC} =5.5V		20	μA	
Control input current	I _I	V _{IN} =5.5V or GND	V _{CC} =0 ~ 5.5V		±0.1	μA	

■ AC ELECTRICAL CHARACTERISTICS (T_A =25°C, unless otherwise specified)

PARAMETER	SYMBOL	TEST CONDITIONS	MIN	TYP	MAX	UNIT
Propagation delay time from COM or Y to Y or COM	t _{PLH} /t _{PHL}	C _L =15pF	V _{CC} =2.5±0.2	1.9	10	ns
			V _{CC} =3.3±0.3	1.2	6	
			V _{CC} =5±0.5	0.7	4	
		C _L =50pF	V _{CC} =2.5±0.2	3.8	12	ns
			V _{CC} =3.3±0.3	2.5	9	
			V _{CC} =5±0.5	1.5	6	
Enable delay time from INH to COM or Y	t _{PZH} /t _{PZL}	C _L =15pF	V _{CC} =2.5±0.2	8	18	ns
			V _{CC} =3.3±0.3	5.7	12	
			V _{CC} =5±0.5	4	8	
		C _L =50pF	V _{CC} =2.5±0.2	9.4	28	ns
			V _{CC} =3.3±0.3	6.7	20	
			V _{CC} =5±0.5	4.7	14	
Disable delay time from INH to COM or Y	t _{PHZ} /t _{PLZ}	C _L =15pF	V _{CC} =2.5±0.2	8.3	18	ns
			V _{CC} =3.3±0.3	6.6	12	
			V _{CC} =5±0.5	5	8	
		C _L =50pF	V _{CC} =2.5±0.2	12.4	28	ns
			V _{CC} =3.3±0.3	9.5	20	
			V _{CC} =5±0.5	6.9	14	

■ CAPACITANCE CHARACTERISTICS (T_A=25°C, unless otherwise specified)

PARAMETER	SYMBOL	TEST CONDITIONS	MIN	TYP	MAX	UNIT
Control input capacitance	C _{IC}	f=10MHz, V _{CC} =3.3V		2.1		pF
COMMON terminal capacitance	C _{IS}	V _{CC} =3.3V		13.1		pF
SWITCH terminal capacitance	C _{OS}	V _{CC} =3.3V		5.6		pF
Feedthrough capacitance	C _F	V _{CC} =3.3V		0.5		pF

■ Analog Switch CHARACTERISTICS (GND=0V, T_A=25°C, unless otherwise specified)

PARAMETER	SYMBOL	TEST CONDITIONS	MIN	TYP	MAX	UNIT
Sine-Wave Distortion from COM or Y to Y or COM	THD	R _L =10k, C _L =50p, f _{IN} =1kHz (sine wave)	V _{IN} =2Vp-p V _{CC} =2.3V		0.1	%
			V _{IN} =2.5Vp-p V _{CC} =3V		0.1	%
			V _{IN} =4Vp-p V _{CC} =4.5V		0.1	%
Frequency response(switch on) from COM or Y to Y or COM	f _{MAX}	R _L =600Ω, C _L =50pF, f _{IN} =1MHz (sine wave)	V _{CC} =2.3V		30	MHz
			V _{CC} =3V		35	MHz
			V _{CC} =4.5V		50	MHz
Feedthrough attenuation from COM or Y to Y or COM (switch off)		R _L =600Ω, C _L =50pF, f _{IN} =1MHz (sine wave)	V _{CC} =2.3V		-45	MHz
			V _{CC} =3V		-45	MHz
			V _{CC} =4.5V		-45	MHz
Crosstalk from COM or Y to Y or COM (between any switches)		R _L =600Ω, C _L =50pF, f _{IN} =1MHz (sine wave)	V _{CC} =2.3V		-45	MHz
			V _{CC} =3V		-45	MHz
			V _{CC} =4.5V		-45	MHz
Crosstalk from INH to COM or Y (control input to signal output)		R _L =600Ω, C _L =50pF, f _{IN} =1MHz (sine wave)	V _{CC} =2.3V		20	mV
			V _{CC} =3V		35	mV
			V _{CC} =4.5V		65	mV

■ OPERATING CHARACTERISTICS (T_A=25°C, unless otherwise specified)

PARAMETER	SYMBOL	TEST CONDITIONS	MIN	TYP	MAX	UNIT
Power Dissipation Capacitance	C _{PD}	C _L =50pF, f=10MHz		11.8		pF

Note: 1. Adjust f_{IN} voltage to obtain 0 dBm at output. Increase fin frequency until dB meter reads -3 dB.
 2. Adjust f_{IN} voltage to obtain 0 dBm at input.

■ TEST CIRCUIT AND WAVEFORMS

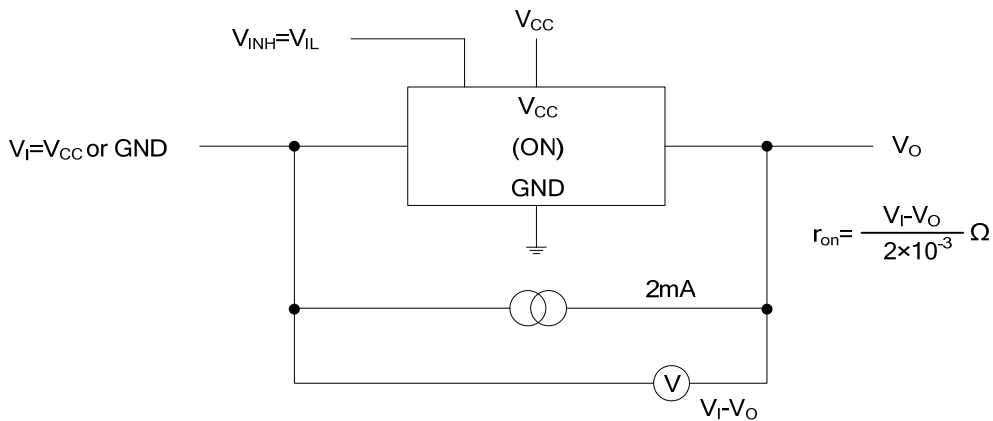

Fig. 1 On-State Resistance Test Circuit

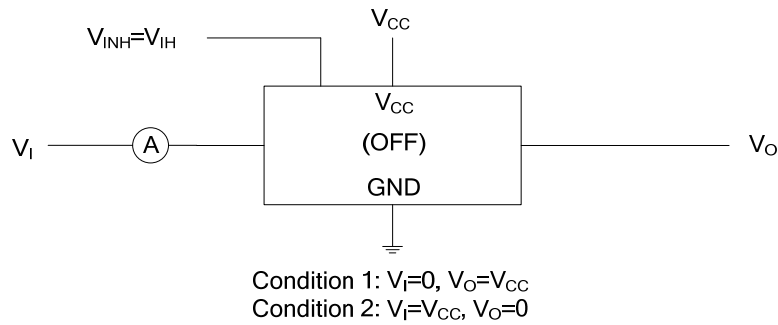

Fig. 2 Off-State Switch Leakage-Current Test Circuit

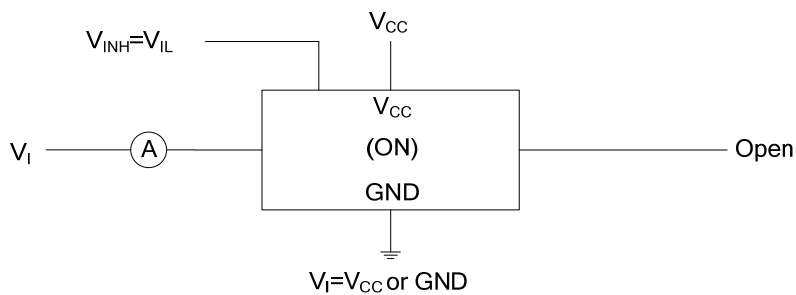

Fig. 3 On-State Switch Leakage-Current Test Circuit

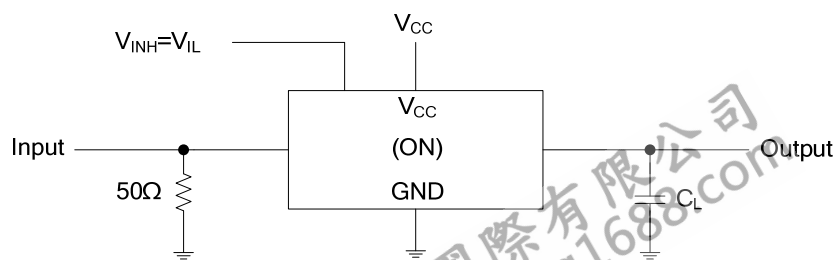

Fig. 4 Propagation Delay Time, Signal Input to Signal Output

■ TEST CIRCUIT AND WAVEFORMS (Cont.)

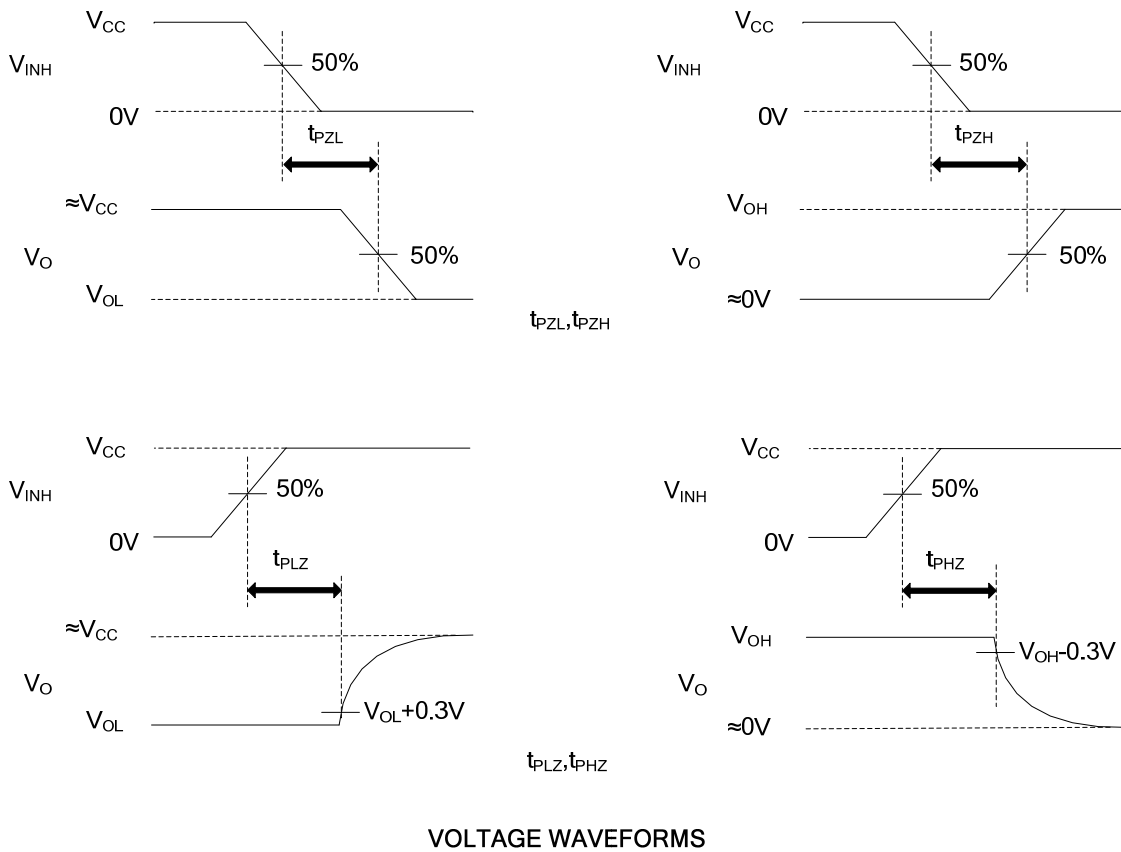
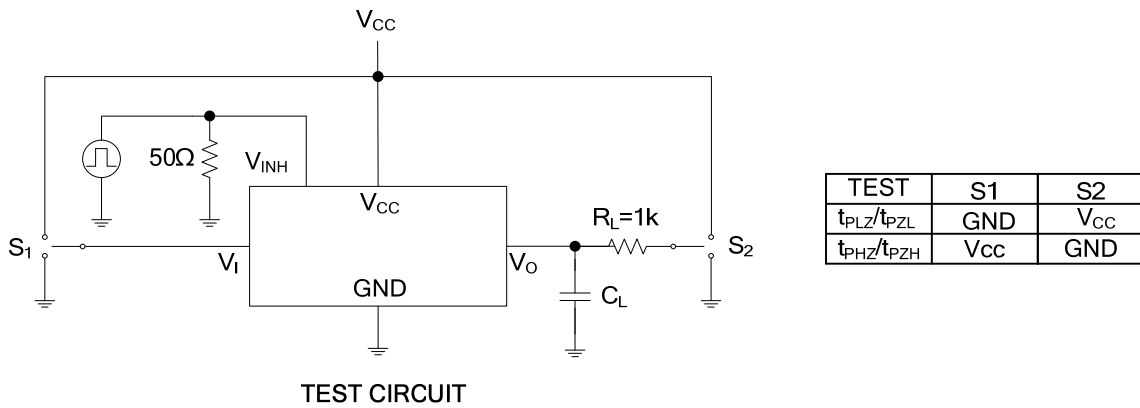
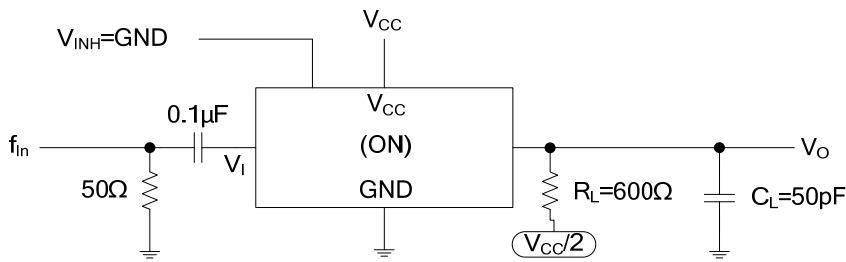

Fig. 5 Switching Time (t_{PZL} , t_{PLZ} , t_{PZH} , t_{PHZ}), Control to Signal Output

■ TEST CIRCUIT AND WAVEFORMS (Cont.)



Note: f_{in} is a sine wave.

Fig. 6 Frequency Response (Switch On)

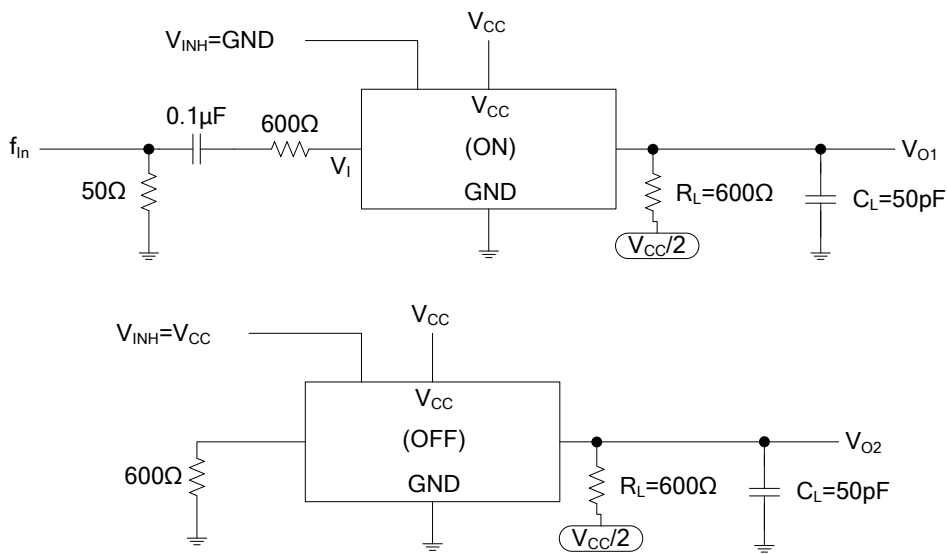

Fig. 7 Crosstalk Between Any Two Switches

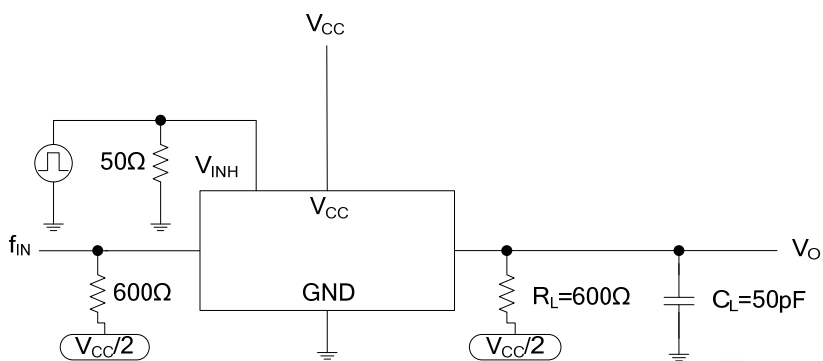

Fig. 8 Crosstalk Between Control Input and Switch Output

■ TEST CIRCUIT AND WAVEFORMS (Cont.)

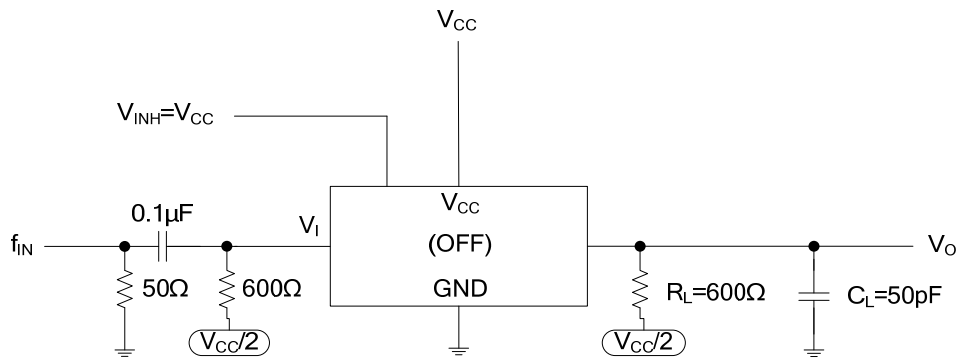

Fig. 9 Feedthrough Attenuation (Switch Off)

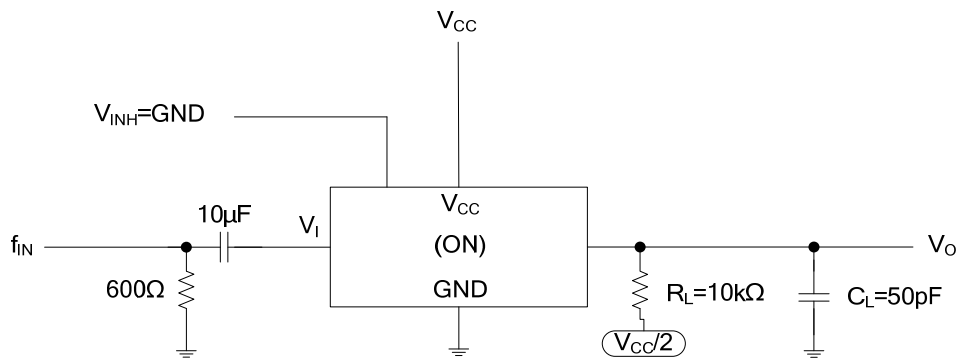

Fig. 10 Sine-Wave Distortion

UTC assumes no responsibility for equipment failures that result from using products at values that exceed, even momentarily, rated values (such as maximum ratings, operating condition ranges, or other parameters) listed in products specifications of any and all UTC products described or contained herein. UTC products are not designed for use in life support appliances, devices or systems where malfunction of these products can be reasonably expected to result in personal injury. Reproduction in whole or in part is prohibited without the prior written consent of the copyright owner. UTC reserves the right to make changes to information published in this document, including without limitation specifications and product descriptions, at any time and without notice. This document supersedes and replaces all information supplied prior to the publication hereof.