



U74LVC07A

CMOS IC

HEX BUFFERS WITH OPEN-DRAIN OUTPUTS

DESCRIPTION

The **U74LVC07A** contain six independent buffers with open drain outputs. The outputs are open-drain and can be connected to other open-drain outputs to implement active-LOW wired-OR or active-HIGH wired-AND functions

Inputs can be driven from 1.8V, 2.5V, 3.3V, or 5V devices. This feature allows the use of these devices as translators in a mixed-system environment.

FEATURES

- * Operate from 1.65V to 5.5V
- * Inputs and open-drain outputs accept voltages to 5.5V
- * Direct interface with TTL levels
- * I_{off} supports partial-power-down mode

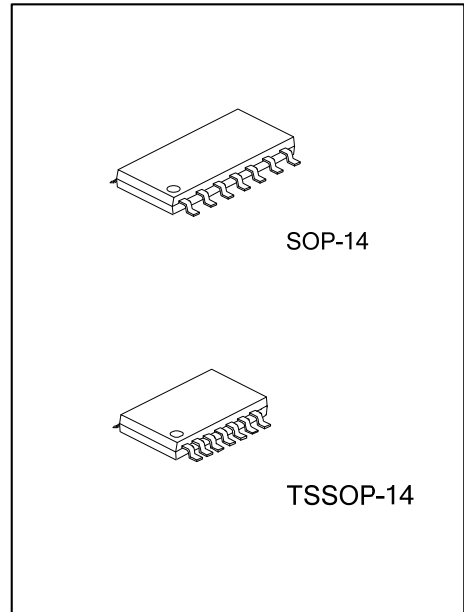

ORDERING INFORMATION

Ordering Number		Package	Packing
Lead Free	Halogen Free		
U74LVC07AL-S14-R	U74LVC07AG-S14-R	SOP-14	Tape Reel
U74LVC07AL-P14-R	U74LVC07AG-P14-R	TSSOP-14	Tape Reel

<p>U74LVC07AG-P14-R</p>	<p>(1) R: Tape Reel (2) P14: TSSOP-14, S14:SOP-14 (3) G: Halogen Free and Lead Free, L: Lead Free</p>
-------------------------	---

MARKING

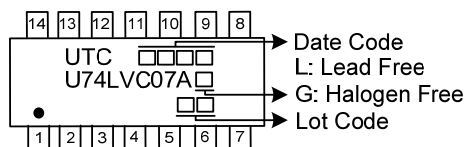

■ PIN CONFIGURATION

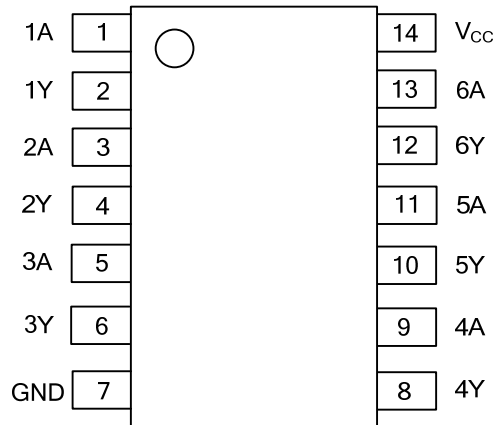

■ FUNCTION TABLE (each buffer)

INPUT(A)	OUTPUT(Y)
H	Z
L	L

Note: H: HIGH voltage level; L: LOW voltage level; Z=high-impedance OFF-state.

■ LOGIC DIAGRAM (each inverter)

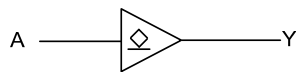

Logic symbol

FLYING 汎翔國際有限公司
www.flying1688.com

■ ABSOLUTE MAXIMUM RATING (T_A =25°C, unless otherwise specified)

PARAMETER	SYMBOL	RATINGS	UNIT
Supply Voltage	V _{CC}	-0.5 ~ +6.5	V
Input Voltage	V _{IN}	-0.5 ~ +6.5	V
Output Voltage	V _{OUT}	-0.5 ~ V _{CC} +0.5	V
V _{CC} or GND Current	I _{CC}	±100	mA
Continuous Output Current (V _{OUT} =0 to V _{CC})	I _{OUT}	50	mA
Input Clamp Current (V _{IN} <0)	I _{IK}	-50	mA
Output Clamp Current (V _{OUT} <0)	I _{OK}	-50	mA
Storage Temperature Range	T _{STG}	-65 ~ +150	°C

Note: Absolute maximum ratings are those values beyond which the device could be permanently damaged. Absolute maximum ratings are stress ratings only and functional device operation is not implied.

■ RECOMMENDED OPERATING CONDITIONS

PARAMETER	SYMBOL	TEST CONDITIONS	MIN	TYP	MAX	UNIT
Supply Voltage	V _{CC}	Operating	1.65		5.5	V
Input Voltage	V _{IN}		0		5.5	V
Output Voltage	V _{OUT}		0		V _{CC}	V
Operating Temperature	T _A		-40		85	°C
Low-level Output Current	I _{OL}	V _{CC} =1.65V			4	mA
		V _{CC} =2.3V			12	mA
		V _{CC} =2.7V			12	mA
		V _{CC} =3V			24	mA
		V _{CC} =4.5V			24	mA

■ THERMAL DATA

PARAMETER	SYMBOL	RATINGS	UNIT	
Junction to Ambient	SOP-14	θ _{JA}	86	°C/W
	TSSOP-14		113	°C/W

■ ELECTRICAL CHARACTERISTICS (T_A =25°C, unless otherwise specified)

PARAMETER	SYMBOL	TEST CONDITIONS	MIN	TYP	MAX	UNIT
High-level Input Voltage	V _{IH}	V _{CC} =1.65V ~ 1.95V	0.65×V _{CC}			V
		V _{CC} =2.3V ~ 2.7V	1.7			V
		V _{CC} =2.7V ~ 3.6V	2			V
		V _{CC} =4.5V ~ 5.5V	0.7×V _{CC}			V
Low-level Input Voltage	V _{IL}	V _{CC} =1.65V ~ 1.95V			0.35×V _{CC}	V
		V _{CC} =2.3V ~ 2.7V			0.7	V
		V _{CC} =2.7V ~ 3.6V			0.8	V
		V _{CC} =4.5V ~ 5.5V			0.3×V _{CC}	V
Low-Level Output Voltage	V _{OL}	V _{CC} =1.65 ~ 5.5V, I _{OL} =100μA			0.2	V
		V _{CC} =1.65V, I _{OL} =4mA			0.45	V
		V _{CC} =2.3V, I _{OL} =12mA			0.7	V
		V _{CC} =2.7V, I _{OL} =12mA			0.4	V
		V _{CC} =3.0V, I _{OL} =24mA			0.55	V
		V _{CC} =4.5V, I _{OL} =32mA			0.55	V
Input Leakage Current	I _{I(LEAK)}	V _{IN} =5.5V or GND, V _{CC} =3.6V			±5	μA
Power OFF Leakage Current	I _{off}	V _{IN} or V _{OUT} =5.5V, V _{CC} =0V			±10	μA
Quiescent Supply Current	I _{CC}	V _{IN} = V _{CC} or GND, I _{OUT} =0 V _{CC} =3.6V			10	μA
Additional Quiescent Supply Current Per Input Pin	ΔI _{CC}	V _{CC} =2.7 ~ 3.6V, I _{OUT} =0 One input at V _{CC} -0.6V, Other inputs at V _{CC} or GND			500	μA
Input Capacitance	C _I	V _{IN} = V _{CC} or GND, V _{CC} =3.3V		5		pF

■ SWITCHING CHARACTERISTICS (T_A =25°C, unless otherwise specified)

PARAMETER	SYMBOL	TEST CONDITIONS	MIN	TYP	MAX	UNIT
Propagation delay from input (nA) to output(nY)	t _{PLZ} t _{PZL}	V _{CC} =1.8±0.15V, C _L =30pF, R _L =1KΩ	1		5.6	ns
		V _{CC} =2.5±0.2V, C _L =30pF, R _L =500Ω	1		3.4	ns
		V _{CC} =2.7V, C _L =50pF, R _L =500Ω			3.3	ns
		V _{CC} =3.3±0.3V, C _L =50pF, R _L =500Ω	1		3.6	ns
		V _{CC} =5±0.5V, C _L =50pF, R _L =500Ω	1		2.6	ns

■ OPERATING CHARACTERISTICS (T_A =25°C, unless otherwise specified)

PARAMETER	SYMBOL	TEST CONDITIONS	MIN	TYP	MAX	UNIT
Power Dissipation Capacitance Per Inverter	C _{PD}	V _{CC} =1.8±0.15V, f=10MHz		1.8		pF
		V _{CC} =2.5±0.2V, f=10MHz		2.0		pF
		V _{CC} =3.3±0.3V, f=10MHz		2.5		pF

■ TEST CIRCUIT AND WAVEFORMS

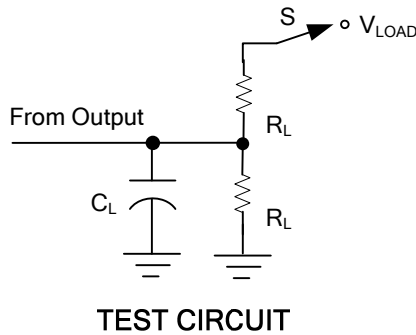

V _{CC}	Inputs		V _M	V _{LOAD}	V _Δ	C _L	R _L
	V _{IN}	t _R , t _F					
1.8V±0.15V	V _{CC}	≤2ns	V _{CC} /2	2 x V _{CC}	0.15V	30pF	1KΩ
2.5V±0.2V	V _{CC}	≤2ns	V _{CC} /2	2 x V _{CC}	0.15V	30pF	500Ω
2.7V	2.7V	≤2.5ns	1.5V	2 x V _{CC}	0.3V	50pF	500Ω
3.3V±0.3V	2.7V	≤2.5ns	1.5V	2 x V _{CC}	0.3V	50pF	500Ω
5V±0.5V	V _{CC}	≤2.5ns	V _{CC} /2	2 x V _{CC}	0.3V	50pF	500Ω

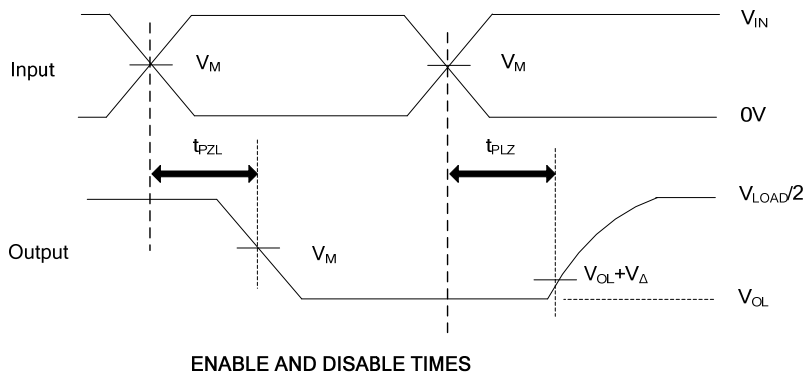

Notes: 1. C_L includes probe and jig capacitance.

2. All input pulses are supplied by generators having the following characteristics: PRR ≤10MHz, Z_O = 50Ω.

UTC assumes no responsibility for equipment failures that result from using products at values that exceed, even momentarily, rated values (such as maximum ratings, operating condition ranges, or other parameters) listed in products specifications of any and all UTC products described or contained herein. UTC products are not designed for use in life support appliances, devices or systems where malfunction of these products can be reasonably expected to result in personal injury. Reproduction in whole or in part is prohibited without the prior written consent of the copyright owner. UTC reserves the right to make changes to information published in this document, including without limitation specifications and product descriptions, at any time and without notice. This document supersedes and replaces all information supplied prior to the publication hereof.