



U74LVC241

CMOS IC

OCTAL BUFFER/DRIVER WITH 3-STATE OUTPUTS

DESCRIPTION

The **U74LVC241** contains two 4-bit line drivers with separate output-enable(1 OE /2OE) inputs. When (1 OE /2OE) is low and high, the device passes data from the A to the Y. When(1 OE /2OE) is high and low, the outputs are in the high-impedance state.

The **U74LVC241** can be used in a mixed 3.3V/5V system environment. This device has power-down protective circuit, preventing device destruction when it is powered down.

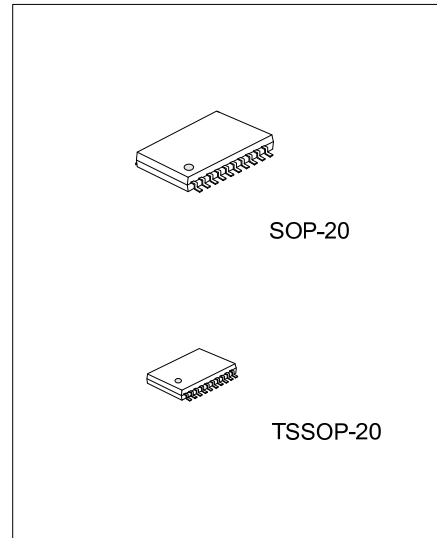

FEATURES

- * Operate From 1.65V to 3.6V
- * Input Accept Voltages to 5.5V
- * Partial-Power-Down Mode Operation
- * Max tpd is 6.1ns at 3.3V

ORDERING INFORMATION

Ordering Number		Package	Packing
Lead Free	Halogen Free		
U74LVC241L-S20-R	U74LVC241G-S20-R	SOP-20	Tape Reel
U74LVC241L-P20-R	U74LVC241G-P20-R	TSSOP-20	Tape Reel

<p>U74LVC241G-R20-R</p> <p>(1)Packing Type</p> <p>(2)Package Type</p> <p>(3)Green Package</p>	<p>(1) R: Tape Reel</p> <p>(2) R20: SSOP-20, P20: TSSOP-20</p> <p>(3) G: Halogen Free and Lead Free</p>
---	---

MARKING

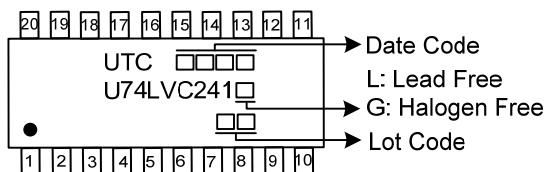

■ PIN CONFIGURATION

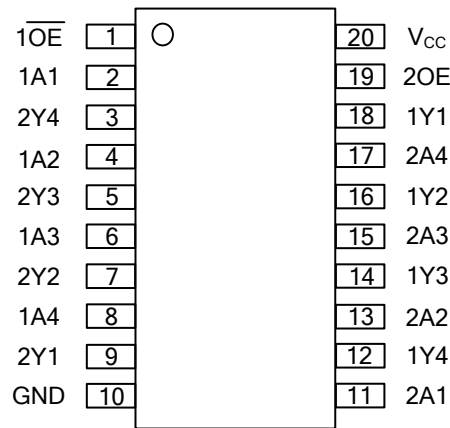

■ FUNCTION TABLE (each gate)

INPUT				OUTPUT	
$\overline{1OE}$	1An	2OE	2An	1Yn	2Yn
L	L	H	L	L	L
L	H	H	H	H	H
H	X	L	X	Z	Z

H = High voltage level ; L = Low voltage level
 X = Don't care ; Z = High-impedance OFF-state

■ LOGIC DIAGRAM (Positive Logic)

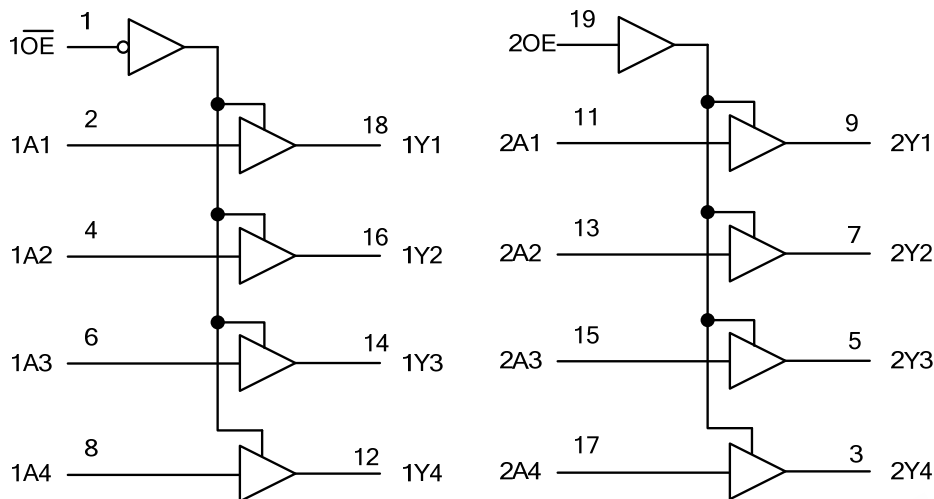

■ ABSOLUTE MAXIMUM RATING

PARAMETER	SYMBOL	CONDITIONS	RATINGS	UNIT
Supply Voltage	V_{CC}		-0.5 ~ +6.5	V
Input Voltage	V_{IN}		-0.5 ~ +6.5	V
Output Voltage	V_{OUT}	Output in the high or low state	-0.5 ~ $V_{CC} + 0.5$	V
		Output in the power-off state	-0.5 ~ +6.5	V
Continuous V_{CC} or GND Current	I_{CC}		±100	mA
Continuous Output Current	I_{OUT}	$V_{OUT}=0V \sim V_{CC}$	±50	mA
Input Clamp Current	I_{IK}	$V_{IN}<0V$	-50	mA
Output Clamp Current	I_{OK}	$V_{OUT}>V_{CC}$ or $V_{OUT}<0V$	-50	mA
Storage Temperature Range	T_{STG}		-65 ~ +150	°C

Note: Absolute maximum ratings are those values beyond which the device could be permanently damaged. Absolute maximum ratings are stress ratings only and functional device operation is not implied.

■ RECOMMENDED OPERATING CONDITIONS

PARAMETER	SYMBOL	TEST CONDITIONS	MIN	TYP	MAX	UNIT
Supply Voltage	V_{CC}	Operating	1.65		3.6	V
		Data retention only	1.2			V
Input Voltage	V_{IN}		0		5.5	V
Output Voltage	V_{OUT}	High or low state	0		V_{CC}	V
		Power-off state	0		5.5	V
Operating Temperature	T_A		-40		85	°C
Input Transition Rise or Fall Rate	$\Delta t/\Delta v$	$V_{CC}=1.65V \sim 2.7V$	0		20	ns/V
		$V_{CC}=2.7V \sim 3.6V$	0		10	ns/V

■ ELECTRICAL CHARACTERISTICS ($T_A = 25^\circ C$, unless otherwise specified)

PARAMETER	SYMBOL	TEST CONDITIONS	MIN	TYP	MAX	UNIT
High-level Input Voltage	V_{IH}	$V_{CC}=1.8V \pm 0.15V$	$0.65 \times V_{CC}$			V
		$V_{CC}=2.5V \pm 0.2V$	1.7			V
		$V_{CC}=3.3V \pm 0.3V$	2			V
Low-level Input Voltage	V_{IL}	$V_{CC}=1.8V \pm 0.15V$			$0.35 \times V_{CC}$	V
		$V_{CC}=2.5V \pm 0.2V$			0.7	V
		$V_{CC}=3.3V \pm 0.3V$			0.8	V
High-Level Output Voltage	V_{OH}	$V_{CC}=1.65 \sim 3.6V, I_{OH}=-100\mu A$	$V_{CC}-0.2$			V
		$V_{CC}=1.65V, I_{OH}=-4mA$	1.2			V
		$V_{CC}=2.3V, I_{OH}=-8mA$	1.7			V
		$V_{CC}=2.7V, I_{OH}=-12mA$	2.2			V
		$V_{CC}=3.0V$				
		$I_{OH}=-18mA$	2.4			V
		$I_{OH}=-24mA$	2.2			V
Low-Level Output Voltage	V_{OL}	$V_{CC}=1.65 \sim 3.6V, I_{OL}=100\mu A$			0.2	V
		$V_{CC}=1.65V, I_{OL}=4mA$			0.45	V
		$V_{CC}=2.3V, I_{OL}=8mA$			0.7	V
		$V_{CC}=2.7V, I_{OL}=12mA$			0.4	V
		$V_{CC}=3.0V, I_{OL}=24mA$			0.55	V

■ ELECTRICAL CHARACTERISTICS (Cont.)

PARAMETER	SYMBOL	TEST CONDITIONS	MIN	TYP	MAX	UNIT
Input Leakage Current	$I_{I(LEAK)}$	$V_{CC}=3.6V, V_{IN}=5.5V$ or GND		± 0.1	± 5	μA
Power OFF Leakage Current	I_{off}	$V_{CC}=0V, V_{IN}$ or $V_{OUT}=5.5V$		0.1	± 10	μA
OFF-state output current	I_{OZ}	$V_{CC}=3.6V, V_{IN} = V_{IH}$ or $V_{IL}, V_{OUT}=5.5V$ or GND		0.1	± 10	μA
Quiescent Supply Current	I_{CC}	$V_{CC}=2.7 \sim 3.6V, V_{IN}=V_{CC} - 0.6V, I_{OUT}=0A$		0.1	10	μA
Additional Quiescent Supply Current Per Input Pin	ΔI_{CC}	$V_{CC}=3 \sim 5.5V, \text{One input at } V_{CC}-0.6V, \text{Other inputs at } V_{CC}$ or GND		5	500	μA
Input Capacitance	C_I	$V_{CC}=0 \sim 3.6V, V_{IN}=GND$ to V_{CC}		5.0		pF

■ SWITCHING CHARACTERISTICS ($T_A = 25^\circ C$, unless otherwise specified)

PARAMETER	SYMBOL	TEST CONDITIONS	MIN	TYP	MAX	UNIT
Propagation delay from input (An) to output(Yn)	t_{PD}	$V_{CC}=1.8V \pm 0.15V$	1.5	5.9	14.1	ns
		$V_{CC}=2.5V \pm 0.2V$	1.0	3.2	7.3	ns
		$V_{CC}=2.7V$	1.5	3.2	7.1	ns
		$V_{CC}=3.3V \pm 0.3V$	1.5	2.7	6.1	ns
Propagation delay from input (1 \overline{OE}) to output(1Yn)	t_{en}	$V_{CC}=1.8V \pm 0.15V$	1.5	6.6	16.2	ns
		$V_{CC}=2.5V \pm 0.2V$	1.5	3.7	8.9	ns
		$V_{CC}=2.7V$	1.5	3.8	8.1	ns
		$V_{CC}=3.3V \pm 0.3V$	1.5	3.0	7.1	ns
Propagation delay from input (2OE) to output(2Yn)	t_{en}	$V_{CC}=1.8V \pm 0.15V$	2.5	5.5	13.8	ns
		$V_{CC}=2.5V \pm 0.2V$	2.1	4.2	7.4	ns
		$V_{CC}=2.7V$	1.5	3.7	8.1	ns
		$V_{CC}=3.3V \pm 0.3V$	1.5	3.4	7.1	ns
Propagation delay from input (1 \overline{OE}) to output(1Yn)	t_{dis}	$V_{CC}=1.8V \pm 0.15V$	2.5	4.3	10	ns
		$V_{CC}=2.5V \pm 0.2V$	1.0	3.5	5.6	ns
		$V_{CC}=2.7V$	1.5	3.2	7.0	ns
		$V_{CC}=3.3V \pm 0.3V$	1.5	3.0	6.0	ns
Propagation delay from input (2OE) to output(2Yn)	t_{dis}	$V_{CC}=1.8V \pm 0.15V$	1.5	3.5	9.9	ns
		$V_{CC}=2.5V \pm 0.2V$	0.5	3.1	5.6	ns
		$V_{CC}=2.7V$	1.5	3.4	7.0	ns
		$V_{CC}=3.3V \pm 0.3V$	1.5	2.6	6.0	ns

■ OPERATING CHARACTERISTICS

($f=10MHz, V_{IN}=GND$ to $V_{CC}, T_A = 25^\circ C$, unless otherwise specified)

PARAMETER	SYMBOL	TEST CONDITIONS	MIN	TYP	MAX	UNIT
Power Dissipation Capacitance	C_{PD}	$V_{CC}=1.8V \pm 0.15V$		14.4		pF
		$V_{CC}=2.5V \pm 0.2V$		17.9		pF
		$V_{CC}=3.3V \pm 0.3V$		21		pF

TEST CIRCUIT AND WAVEFORMS

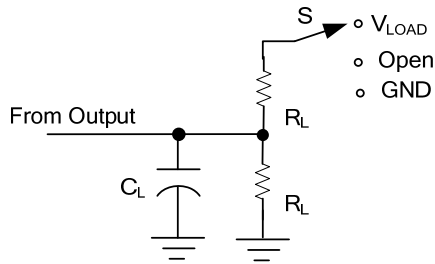

TEST	S
t_{PLH}/t_{PHL}	Open
t_{PHZ}/t_{PZH}	GND
t_{PLZ}/t_{PLZ}	V_{LOAD}

TEST CIRCUIT

V_{CC}	V_{IN}	t_R/t_F	V_M	V_{Δ}	C_L	R_L	V_{EXT}		
							t_{PLH}/t_{PHL}	t_{PZH}/t_{PHZ}	t_{PLZ}/t_{PLZ}
$1.8V \pm 0.15V$	V_{CC}	$\leq 2ns$	$V_{CC}/2$	0.15V	30pF	1K Ω	OPEN	GND	$2 \times V_{CC}$
$2.5V \pm 0.2V$	V_{CC}	$\leq 2ns$	$V_{CC}/2$	0.15V	30pF	500 Ω	OPEN	GND	$2 \times V_{CC}$
2.7V	2.7V	$\leq 2.5ns$	1.5V	0.3V	50pF	500 Ω	OPEN	GND	$2 \times V_{CC}$
$3.3V \pm 0.3V$	2.7V	$\leq 2.5ns$	1.5V	0.3V	50pF	500 Ω	OPEN	GND	$2 \times V_{CC}$

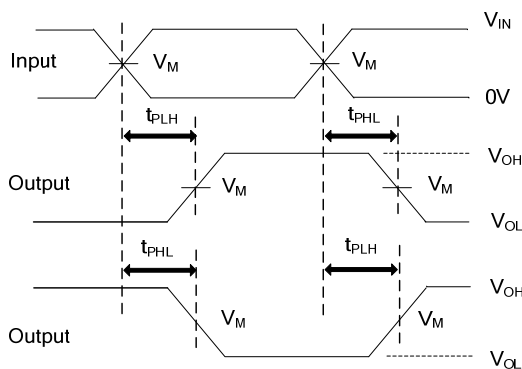

PROPAGATION DELAY TIMES

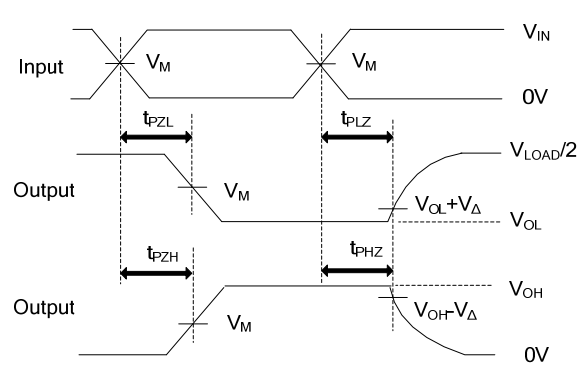

ENABLE AND DISABLE TIMES

Notes: 1. C_L includes probe and jig capacitance.

2. All input pulses are supplied by generators having the following characteristics: PRR $\leq 10MHz$, $Z_O = 50\Omega$.

UTC assumes no responsibility for equipment failures that result from using products at values that exceed, even momentarily, rated values (such as maximum ratings, operating condition ranges, or other parameters) listed in products specifications of any and all UTC products described or contained herein. UTC products are not designed for use in life support appliances, devices or systems where malfunction of these products can be reasonably expected to result in personal injury. Reproduction in whole or in part is prohibited without the prior written consent of the copyright owner. UTC reserves the right to make changes to information published in this document, including without limitation specifications and product descriptions, at any time and without notice. This document supersedes and replaces all information supplied prior to the publication hereof.