



U74LVC573

CMOS IC

OCTAL TRANSPARENT D-TYPE LATCHES WITH 3-STATE OUTPUTS

DESCRIPTION

The **U74LVC573** is a octal transparent D-type latch with 3-state outputs, and it has 8 channels.

FEATURES

- * Operate from 1.65V to 3.6V
- * Max t_{PD} of 7.7ns @ 3.3 V
- * Typical $V_{OL} < 0.8V$ @ $V_{CC} = 3.3V, T_A = 25^\circ C$
- * Typical $V_{OH} > 2V$ @ $V_{CC} = 3.3V, T_A = 25^\circ C$
- * Power off disables outputs, permitting live insertion

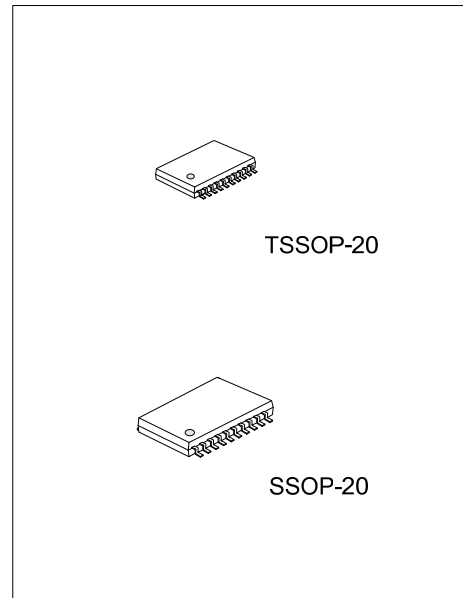

ORDERING INFORMATION

Ordering Number		Package	Packing
Lead Free	Halogen Free		
U74LVC573L-R20-R	U74LVC573G-R20-R	SSOP-20	Tape Reel
U74LVC573L-P20-R	U74LVC573G-P20-R	TSSOP-20	Tape Reel

<p>U74LVC573G-R20-R</p> <p>(1) Packing Type (2) Package Type (3) Green Package</p>	<p>(1) R: Tape Reel (2) P20: TSSOP-20, R20: SSOP-20, (3) G: Halogen Free and Lead Free, L: Lead Free</p>
--	--

MARKING

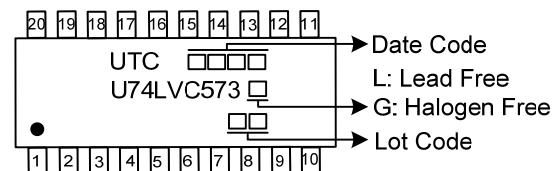

■ PIN CONFIGURATION

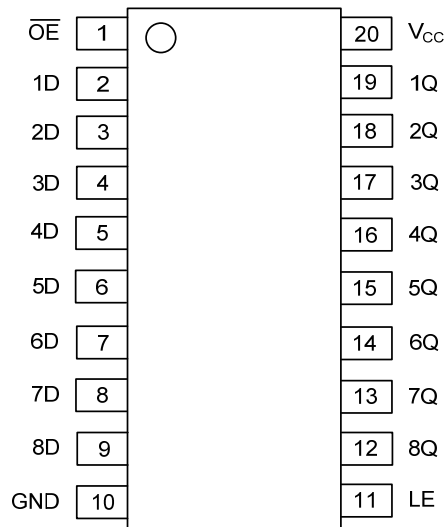

■ FUNCTION TABLE

INPUTS (\overline{OE})	INPUTS(LE)	INPUTS(D)	OUTPUT(Q)
L	H	H	H
L	H	L	L
L	L	X	Q0
H	X	X	Z

Note: H: HIGH voltage level; L: LOW voltage level.

■ LOGIC SYMBOL

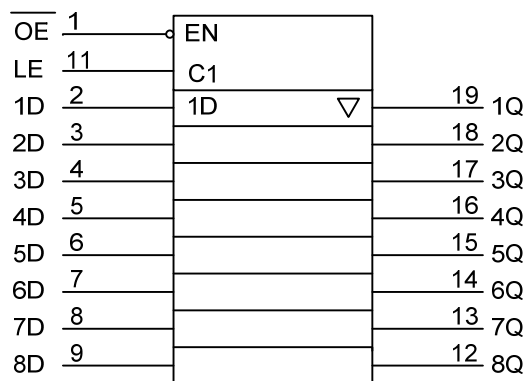

■ LOGIC DIAGRAM

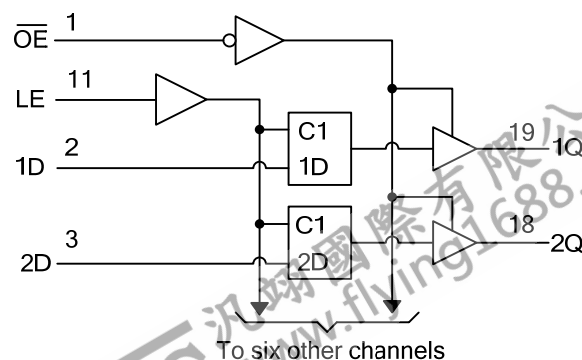

■ ABSOLUTE MAXIMUM RATING

PARAMETER	SYMBOL	RATINGS	UNIT
Supply Voltage	V_{CC}	-0.5 ~ 6.5	V
Input Voltage	V_{IN}	-0.5 ~ 6.5	V
Output Voltage	V_{OUT}	-0.5 ~ 6.5 (Note 2)	V
		-0.5 ~ V_{CC} +0.5 (Note 3)	V
V_{CC} or GND Current	I_{CC}	±100	mA
Output Current	I_{OUT}	±50	mA
Input Clamp Current	I_{IK}	-50	mA
Output Clamp Current	I_{OK}	-50	mA
Operating Temperature	T_{OPR}	-40 ~ + 85	°C
Storage Temperature	T_{STG}	-65 ~ + 150	°C

Note: 1. Absolute maximum ratings are those values beyond which the device could be permanently damaged.

Absolute maximum ratings are stress ratings only and functional device operation is not implied.

2. Voltage range applied to any output in the high-impedance or power-off state.

3. Voltage range applied to any output in the high or low state, and V_{CC} is provided in the recommended operating conditions table.

■ THERMAL

PARAMETER	SYMBOL	RATINGS	UNIT
Junction to Ambient	SSOP-20	70	°C/W
	TSSOP-20	83	°C/W

■ RECOMMENDED OPERATING CONDITIONS

PARAMETER	SYMBOL	TEST CONDITIONS	MIN	TYP	MAX	UNIT
Supply Voltage	V_{CC}	Operating	1.65		3.6	V
		Data retention only	1.5			V
High-level Input Voltage	V_{IH}	$V_{CC}=1.65V$ to 1.95V	0.65 $\times V_{CC}$			V
		$V_{CC}=2.3V$ to 2.7V	1.7			V
		$V_{CC}=2.7V$ to 3.6V	2			V
Low-level Input Voltage	V_{IL}	$V_{CC}=1.65V$ to 1.95V			0.35 $\times V_{CC}$	V
		$V_{CC}=2.3V$ to 2.7V			0.7	V
		$V_{CC}=2.7V$ to 3.6V			0.8	V
Input Voltage	V_{IN}		0		5.5	V
Output Voltage	V_{OUT}	High or low state	0		V_{CC}	V
		3 state	0		5.5	V
High-level Output Current	I_{OH}	$V_{CC}=1.65V$			-4	mA
		$V_{CC}=2.3V$			-8	mA
		$V_{CC}=2.7V$			-12	mA
		$V_{CC}=3V$			-24	mA
Low-level Output Current	I_{OL}	$V_{CC}=1.65V$			4	mA
		$V_{CC}=2.3V$			8	mA
		$V_{CC}=2.7V$			12	mA
		$V_{CC}=3V$			24	mA
Input Rise or Fall Times	t_{R}, t_{F}				6	ns/V

■ ELECTRICAL CHARACTERISTICS

PARAMETER	SYMBOL	TEST CONDITIONS	MIN	TYP (Note1)	MAX	UNIT
Output Voltage High-Level	V_{OH}	$V_{CC}=1.65\sim 3.6V, I_{OH}=-100\mu A$	V_{CC} -0.2			V
		$V_{CC}=1.65V, I_{OH}=-4mA$	1.2			V
		$V_{CC}=2.3V, I_{OH}=-8mA$	1.7			V
		$V_{CC}=2.7V, I_{OH}=-12mA$	2.2			V
		$V_{CC}=3V, I_{OH}=-12mA$	2.4			V
		$V_{CC}=3V, I_{OH}=-24mA$	2.2			V
Output Voltage Low-Level	V_{OL}	$V_{CC}=1.65\sim 3.6V, I_{OL}=100\mu A$			0.2	V
		$V_{CC}=1.65V, I_{OL}=4mA$			0.45	V
		$V_{CC}=2.3V, I_{OL}=8mA$			0.7	V
		$V_{CC}=2.7V, I_{OL}=12mA$			0.4	V
		$V_{CC}=3V, I_{OL}=24mA$			0.55	V
Input Leakage Current	$I_{I(LEAK)}$	$V_{CC}=3.6V, V_{IN}=0$ to 5.5V			± 5	μA
Power OFF Leakage Current	I_{OFF}	$V_{CC}=0V, V_{IN}$ or $V_{OUT}=5.5V$			± 10	μA
Disable Output Leakage Current	I_{OZ}	$V_{CC}=3.6V, V_{OUT}=0$ to 5.5V			± 10	μA
Quiescent Supply Current	I_Q	$V_{CC}=3.6V, V_{IN}=V_{CC}$ or GND, $I_{OUT}=0$			10	μA
		$V_{CC}=3.6V, 3.6V \leq V_{IN} \leq 5.5V, I_{OUT}=0$ (Note 2)			10	μA
Additional Quiescent Supply Current	ΔI_Q	$V_{CC}=2.7\sim 3.6V$ One input at $V_{CC}-0.6V$ Other inputs at V_{CC} or GND			500	μA
Input Capacitance	C_I	$V_{CC}=3.3V, V_{IN}=V_{CC}$ or GND		4		pF
Output Capacitance	C_O	$V_{CC}=3.3V, V_{OUT}=V_{CC}$ or GND		5.5		pF

Note: 1. $V_{CC}=3.3V, T_A=25^\circ C$

2. This applies in the disabled state only.

■ SWITCHING CHARACTERISTICS

PARAMETER	SYMBOL	TEST CONDITIONS	MIN	TYP	MAX	UNIT
From D to Q	t_{PLH}/t_{PHL}	$V_{CC}=2.7V$			7.7	ns
		$V_{CC}=3.3V \pm 0.3V$	1.5		6.9	
From LE to Q		$V_{CC}=2.7V$			8.4	
		$V_{CC}=3.3V \pm 0.3V$	2		7.7	
From \overline{OE} to Q	t_{PZL}/t_{PZH}	$V_{CC}=2.7V$			8.5	ns
		$V_{CC}=3.3V \pm 0.3V$	1.5		7.5	
From \overline{OE} to Q	t_{PLZ}/t_{PHZ}	$V_{CC}=2.7V$			7	ns
		$V_{CC}=3.3V \pm 0.3V$	1.6		6.5	
Pulse Width	t_W	$V_{CC}=2.7V$	3.3			ns
		$V_{CC}=3.3V \pm 0.3V$	3.3			
Setup Time	t_{SU}	$V_{CC}=2.7V$	2			ns
		$V_{CC}=3.3V \pm 0.3V$	2			
Hold Time	t_H	$V_{CC}=2.7V$	2.5			ns
		$V_{CC}=3.3V \pm 0.3V$	2.5			

■ OPERATING CHARACTERISTICS ($T_A=25^\circ C$)

PARAMETER	SYMBOL	TEST CONDITIONS	RATINGS	UNIT
Power Dissipation Capacitance	C_{PD}	$\overline{OE}=0, f=10MHz, V_{CC}=3.3V \pm 0.3V$	37	pF
		$\overline{OE}=1, f=10MHz, V_{CC}=3.3V \pm 0.3V$	4	

TEST CIRCUIT AND WAVEFORMS

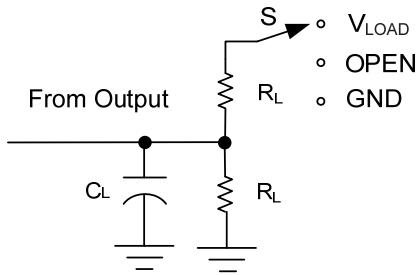

TEST CIRCUIT

V_{CC}	V_{IN}	t_{PLZ}/t_{PZL} (V_{LOAD})	t_{PLH}/t_{PHL}	t_{PHZ}/t_{PZH}	C_L	R_L (Note 1)	ΔV
$1.8V \pm 0.15V$	V_{CC}	$2 \times V_{CC}$	OPEN	OPEN	30pF	1k Ω	0.15V
$2.5V \pm 0.2V$	V_{CC}	$2 \times V_{CC}$	OPEN	GND	30pF	500 Ω	0.15V
2.7V	2.7V	6V	OPEN	GND	50pF	500 Ω	0.3V
$3.3V \pm 0.3V$	2.7V	6V	OPEN	GND	50pF	500 Ω	0.3V

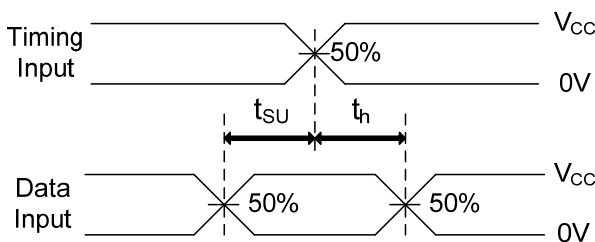

SETUP TIME AND HOLD TIME

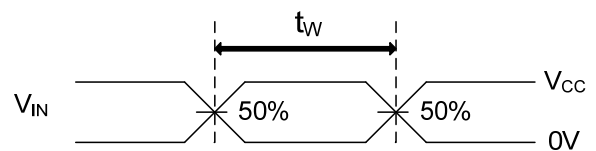

PULSE WIDTH

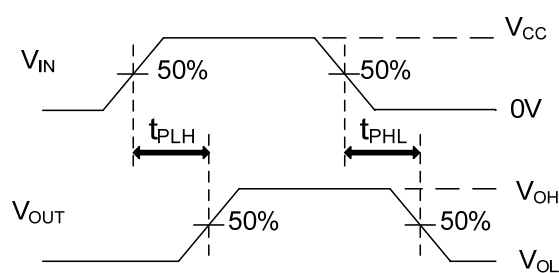

PROPAGATION DELAY TIMES

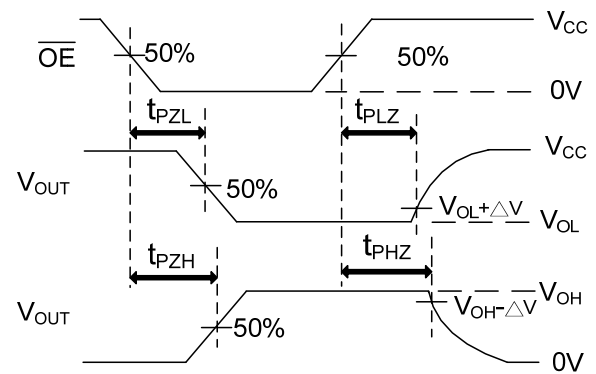

ENABLE AND DISABLE TIMES

Note: 1. C_L includes probe and jig capacitance.
 2. $P_{RR} \leq 10\text{MHz}$, $Z_o = 50\Omega$, $t_{THL} \leq 2\text{ns}$, $t_{TLH} \leq 2\text{ns}$.

UTC assumes no responsibility for equipment failures that result from using products at values that exceed, even momentarily, rated values (such as maximum ratings, operating condition ranges, or other parameters) listed in products specifications of any and all UTC products described or contained herein. UTC products are not designed for use in life support appliances, devices or systems where malfunction of these products can be reasonably expected to result in personal injury. Reproduction in whole or in part is prohibited without the prior written consent of the copyright owner. UTC reserves the right to make changes to information published in this document, including without limitation specifications and product descriptions, at any time and without notice. This document supersedes and replaces all information supplied prior to the publication hereof.