



U8C3005

Preliminary

LINEAR INTEGRATED CIRCUIT

8 BIT SERIAL-IN PARALLEL-OUT VALVE DRIVER

DESCRIPTION

The **U8C3005** is a 8-Bit Serial-In Parallel-Out driver with Error Detection to the solenoid valve drive. The device incorporates shift registers, data latches, and constant current circuitry on the silicon CMOS chip. The maximum output current value of one channel is Approximately limited to 50-85mA by Built-in constant current source.

The range of power supply PV_{DD} is 8V to 30V and the Integrated internal 6V Regulator is used for low-voltage power supply module communication. Moreover, PV_{DD} can be also used to absorb the inductive coil reverse-phase current with a built-in reverse diode Between the output of each channel and PV_{DD} in the time of turn off.

Its built-in open/short detection circuits help users detect Load state of the detection channels. System retrieve the error messages to indicate which channel has failure by serial output data.

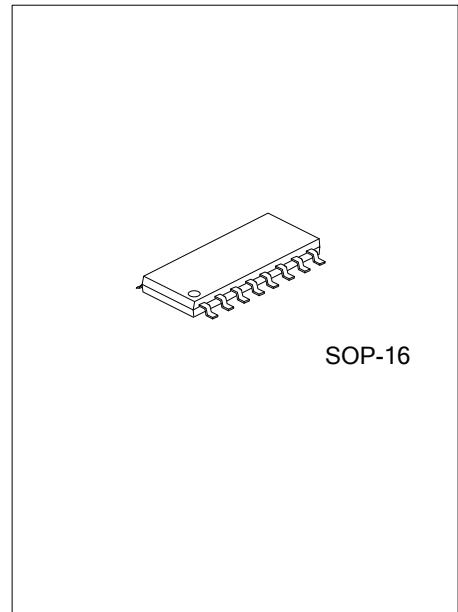

SOP-16

FEATURES

- * V_{DD} range: PV_{DD} 8V to 30V
- * each channel current limit: 50mA
- * Integrated internal 6V regulator
- * Maximum clock frequency: 0.5MHz
- * Built-in open/short detection
- * Short protect
- * Detecting response
- * Internal reverse diode of PV_{DD} to Absorb reverse current from coil

ORDERING INFORMATION

Ordering Number		Package	Packing
Lead Free	Halogen Free		
U8C3005L-S16-R	U8C3005G-S16-R	SOP-16	Tape Reel

<p>U8C3005G-S16-R</p> <ul style="list-style-type: none"> (1) Packing Type (2) Package Type (3) Green Package 	<ul style="list-style-type: none"> (1) R: Tape Reel (2) S16: SOP-16 (3) G: Halogen Free and Lead Free, L: Lead Free
---	--

MARKING

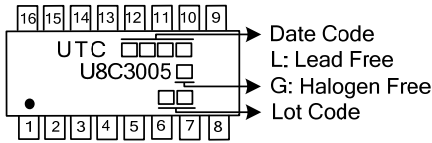

PIN CONFIGURATION



PIN DESCRIPTION

PIN NO.	PIN NAME	DESCRIPTION
1	GND	Ground terminal
2	SDI	Serial data input terminal.
3	SDO	Serial data output terminal.
4	OE	Output enable terminal: 'H' for all outputs are turned off,' L' for all outputs are active.
5	N.C	None connection.
6	SCLK	Synchronous clock input terminal for serial data transfer. Data is sampled at the rising edge of SCLK.
7	V _{DD}	Integrated internal 6V Regulator output
8	PV _{DD}	Power Supply voltage terminal. To absorb the inductive load reverse current of Driver-side
9-16	Drian0 ~ Drain7	Sink constant-current outputs (open-drain).

■ BLOCK DIAGRAM

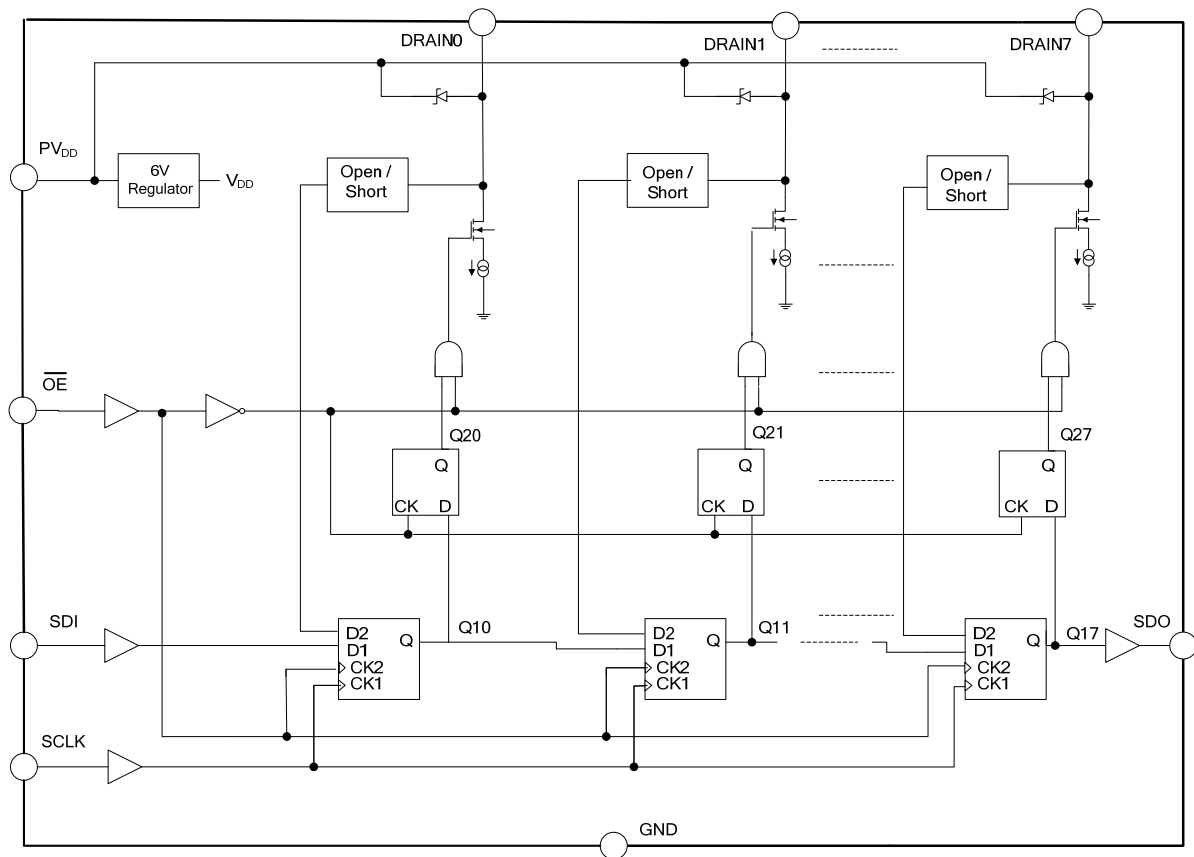

FLYING 汎翔國際有限公司
www.flying1688.com

■ ABSOLUTE MAXIMUM RATING

PARAMETER	SYMBOL	RATINGS	UNIT
Voltage On Terminals	PV _{DD}	-0.5 ~ 30	V
Voltage On Terminals	V _{DD}	-0.5 ~ 7.0	V
Voltage On Terminals	SDO	-0.5 ~ V _{DD} +0.5	V
Voltage On Terminals	Input	-0.5 ~ PV _{DD} +0.5	V
Power Dissipation (Temperature=25°)	P _D	1	W
Operational Temperature Range	T _J	-30 ~ +70	°C
Storage Temperature Range	T _{STG}	-40 ~ +85	°C

Note: Absolute maximum ratings are those values beyond which the device could be permanently damaged. Absolute maximum ratings are stress ratings only and functional device operation is not implied.

■ RECOMMENDED OPERATING CONDITIONS

PARAMETER	SYMBOL	MIN	TYP	MAX	UNIT
Power Supply	PV _{DD}	8		30	V
Input Digital Clock Frequency	f _{SCLK}			0.5	MHz
SCLK Pulse Width	T _{SCLK}	750			ns
OE Pulse Width	T _{OE}	2			us
OE to SCLK Rise	T _{OE-SCLK}	2			us

■ TIMING SEQUENCE PARAMETER (T_A =25°C, unless otherwise specified)

PARAMETER	SYMBOL	TEST CONDITIONS	MIN	TYP	MAX	UNIT
Supply Current	I _{ON}	PV _{DD} =20V, Channel On	2.4	3.2	4	mA
Supply Current	I _{OFF}	PV _{DD} =20V, Channel Off	1.3	1.8	2.3	mA
Output Voltage High (SDO)	V _{OH}		5.5	6	6.5	V
Input High Voltage	V _{IH}		3		18	V
Input Low Voltage	V _{IL}				0.8	V
Limiting Current	I _{LIMIT}		50	68	85	mA/ch
Output Voltage of Each Channel	V _{DS_ON}	Channel On, I _{OUT} =30mA			0.6	V
Maximum Power Voltage Supply	V _{DS-OFF}	Channel Off	30			V

■ TYPICAL APPLICATION CIRCUIT

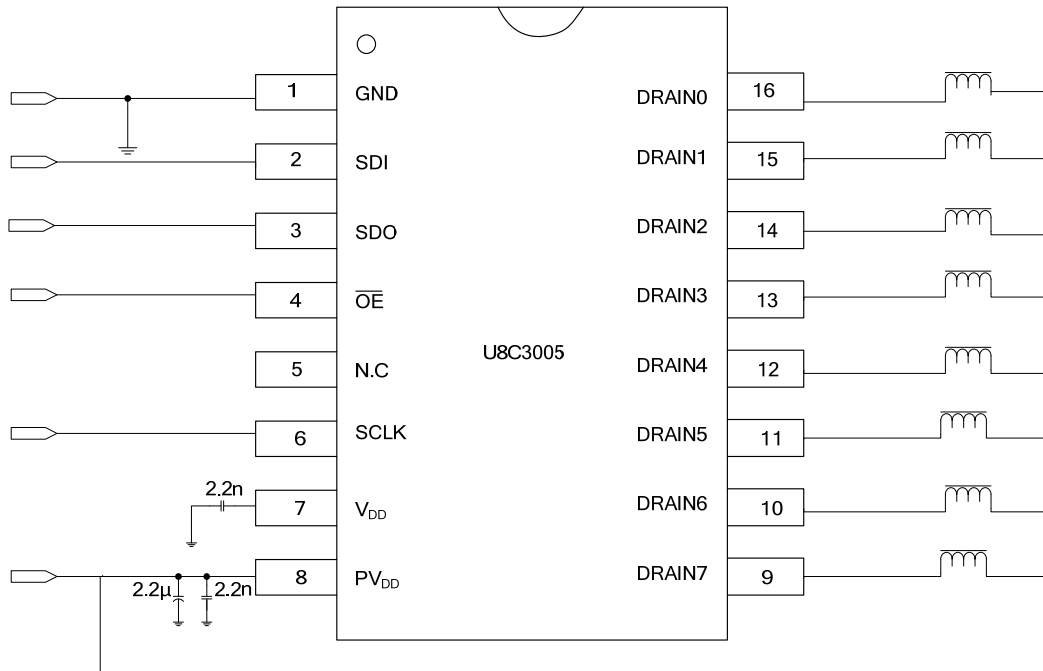

■ TIMING DIAGRAM

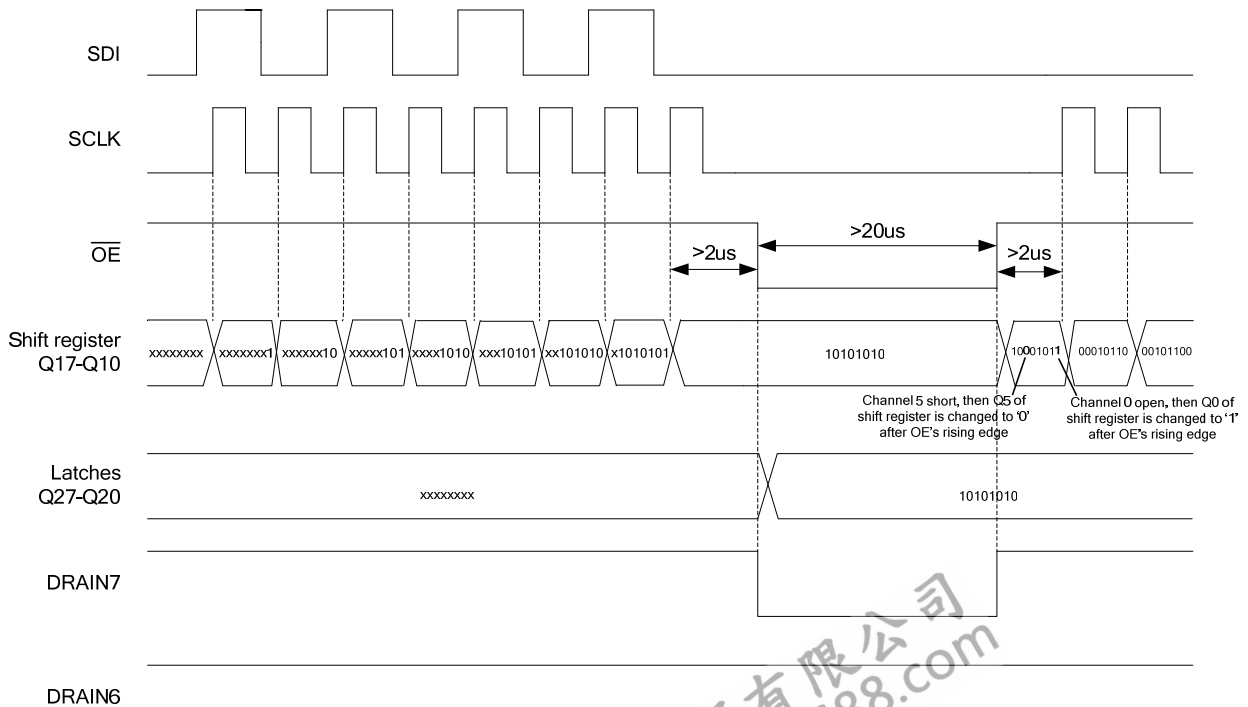

■ CIRCUIT DESCRIPTION

The **U8C3005** is a 8-Bit Serial-In Parallel-Out driver for Solenoid valve. When \overline{OE} in the falling edge, the data of shift registers are written to the latch registers. The state of outputs Drain0 ~ Drain7 are controlled by the latch data Q20 ~ Q27 and \overline{OE} signal. when \overline{OE} is low, if a channel corresponding data latch is 1, then the channel output is turned on, the switch from the output terminal to ground in the on state, if a channel corresponding data latch is 0, the switch from the output terminal to ground are turned off, In a high impedance state. When \overline{OE} is high, the eight outputs are turned off, In a high impedance state.

U8C3005's constant current technology make the maximum output current limited to around 50-85mA, which can effectively prevent the chip or peripheral devices from damaging caused by load short.

■ OPEN/SHORT DETECTION

The result of open/short detection of **U8C3005** could be retrieved from serial-out (SDO) data. Once the load of a channel in Open state or short state, the chip can be detected in time and quickly Shutdown the load shorted channel which the chip from can over heating and external load. The test results stored to the shift register when \overline{OE} rising edge. It Can be removed from SDO end of the serial at SCLK action reading back to the controller.

The controller will read back the data before sending out now Control data for comparison, if exactly the same, it means the load in good condition, no open short circuit, if a bit of data sent out is 1, 0 read back, it indicates that the corresponding channel bit data load short circuit occurs, if a bit of data to send out is 0, 1 read back, the table Shows the bit data corresponding to the channel occurred Open load.

UTC assumes no responsibility for equipment failures that result from using products at values that exceed, even momentarily, rated values (such as maximum ratings, operating condition ranges, or other parameters) listed in products specifications of any and all UTC products described or contained herein. UTC products are not designed for use in life support appliances, devices or systems where malfunction of these products can be reasonably expected to result in personal injury. Reproduction in whole or in part is prohibited without the prior written consent of the copyright owner. The information presented in this document does not form part of any quotation or contract, is believed to be accurate and reliable and may be changed without notice.