



ONE-CELL STANDALONE LINEAR LITHIUM BATTERY CHARGER

DESCRIPTION

The UTC **UB10803** is a fully-integrated single-cell Li-ion/Polymer battery charger. The device operates without external FET and blocking diode, and employs a constant-current constant-voltage (CC/CV) charging profile.

The fast-charge and end-of-charge (EOC) currents are programmable with independent external resistors. When the battery is deeply discharged to lower than 2.75V, the charger firstly pre-charges the battery with typically 20% of the programmable fast-charge current. When the charge current is reduced to the programmed EOC current level (almost works completely in a constant-voltage (CV) mode), an EOC indication is displayed through the CHG pins. The UTC **UB10803** is protected by thermal regulation technology to prevent the IC from over-heat during charging.

Two status indication pins (PPR and CHG), which are both implemented as an open-drain outputs, can be used to drive LEDs or work as logic interface to a microprocessor. When no adapter is attached or when the charger is disabled, the leakage current from battery cell is less than 1uA typically.

FEATURES

- * A Constant-Current/Constant-Voltage Linear Charger for Single-Cell Li-ion/Polymer Batteries
- * Integrated Pass Element and Current Sensor
- * Highly-Integrated, Requiring No External FETs or Blocking Diode
- * 4.2V Voltage Accuracy: $\pm 1.2\%$ All Temperatures (Available with 4.10V and 4.36V options upon request)
- * Programmable Charge Current 50mA to 500mA
- * Programmable End-Of-Charge Current by Current Recharge Algorithm
- * Pre-Charge for Fully Discharged Batteries
- * 1 μ A (Typ.) Leakage Current of the Battery when No Input Power is Attached or Charger is Disabled
- * Power Present and Charge Status Indications
- * Thermal Regulation on Charging Current to Prevent Over-Heat
- * Few Components, Cost-Effective Solutions

ORDERING INFORMATION

Ordering Number	Package	Packing
UB10803G-SH2-R	HSOP-8	Tape Reel
UB10803G- K08-2030-R	DFN-8(2x3)	Tape Reel

<p>UB10803L-SH2-T</p> <p>(1)Packing Type</p> <p>(2)Package Type</p> <p>(3)Lead Free</p>	<p>(1) T: Tube, R: Tape Reel</p> <p>(2) HS2: HSOP-8, K08-2030: DFN-8(2x3)</p> <p>(3) L: Lead Free, G: Halogen Free</p>
---	--

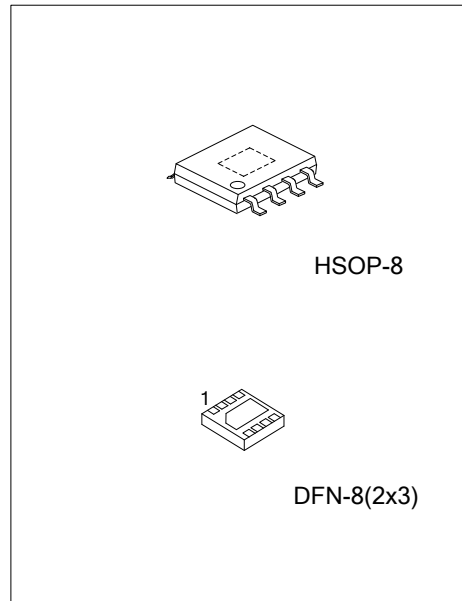

MARKING

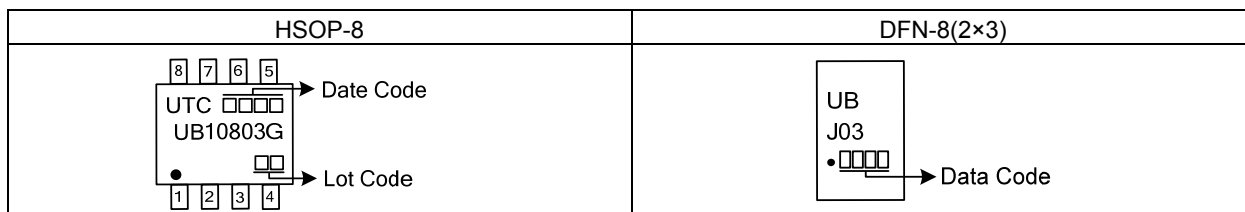

PIN CONFIGURATION

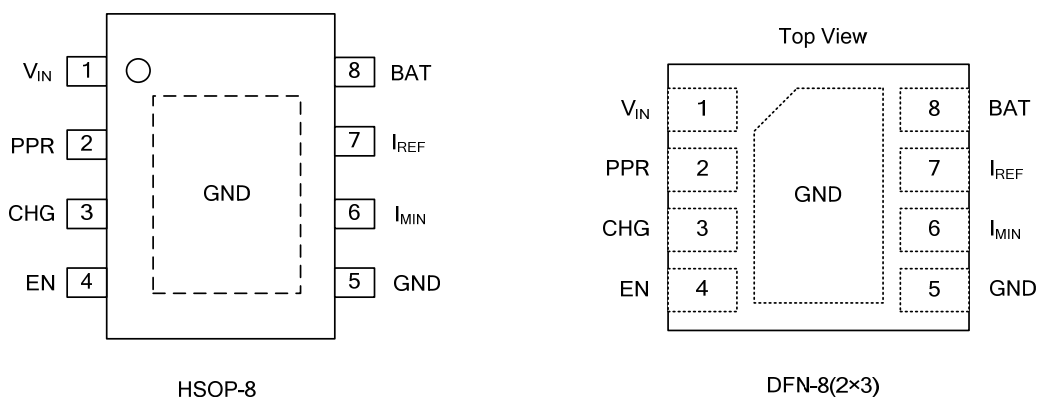

PIN DESCRIPTION

PIN NO.	PIN NAME	DESCRIPTION
1	V _{IN}	Supply Input
2	PPR	Power Present Active-Low Open Drain Power Status Indicator
3	CHG	Charge Active-Low Open Drain Charge Status Indicator
4	EN	Enable Active-Low Input
5	GND	Ground
6	I _{MIN}	End-Of-Charge Current Setting Input
7	I _{REF}	Charge Current Setting Input for Adaptor Mode
8	BAT	Battery Terminal

■ BLOCK DIAGRAM

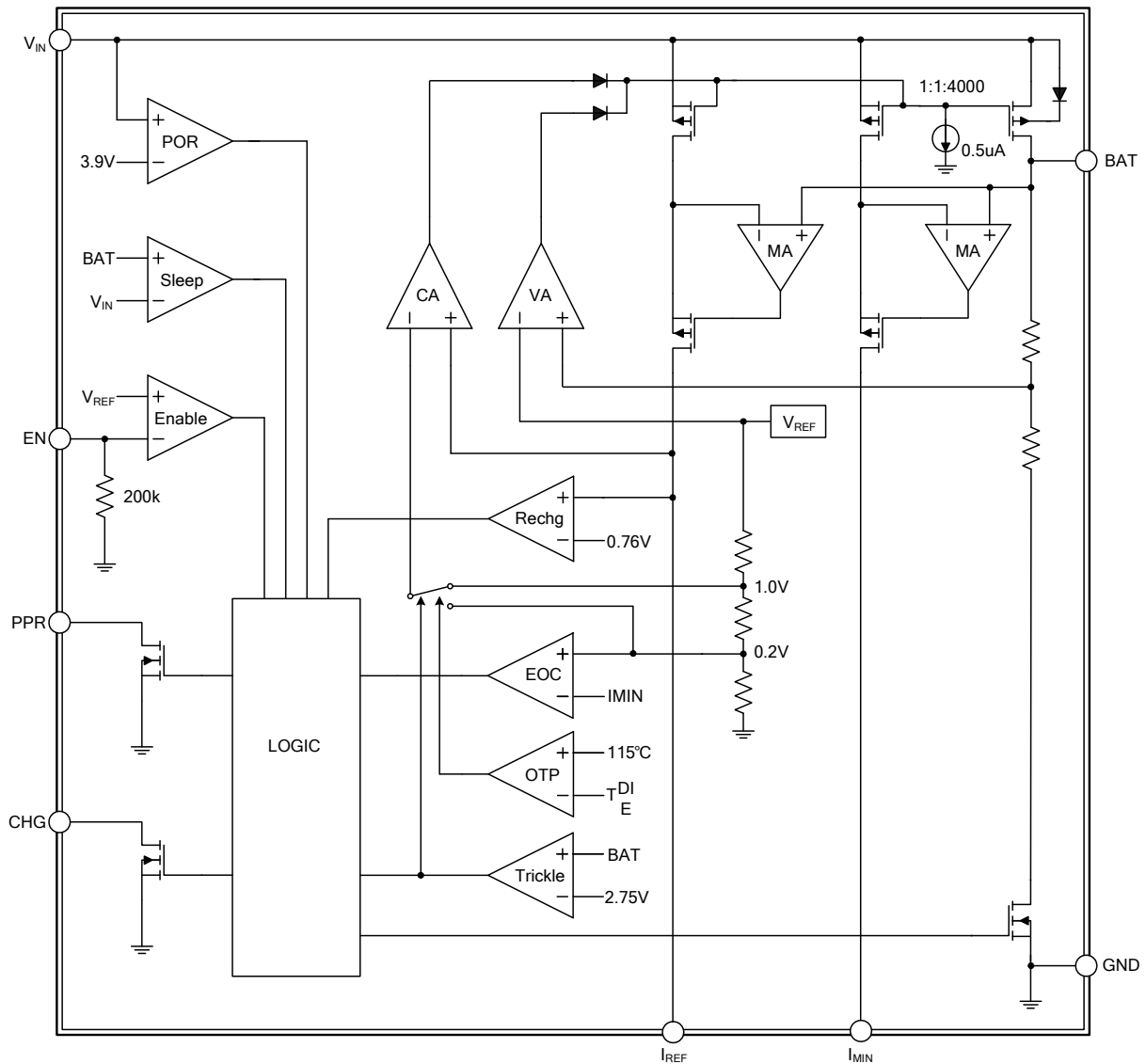

FLYING 汎翔國際有限公司
www.flying1688.com

■ ABSOLUTE MAXIMUM RATINGS

PARAMETER	SYMBOL	RATINGS	UNIT
Input Supply Voltage	V_{IN}	-0.3 ~ +7.0	V
I _{REF} Voltage	V_{IREF}	-0.3 ~ +7.0	V
I _{MIN} Voltage	V_{IMIN}	-0.3 ~ +7.0	V
BAT Voltage	V_{BAT}	-0.3 ~ +7.0	V
EN Voltage	V_{EN}	-0.3 ~ +7.0	V
CHG Voltage	V_{CHG}	-0.3 ~ +7.0	V
PPR Voltage	V_{PPR}	-0.3 ~ +7.0	V

Notes: 1. Absolute maximum ratings are those values beyond which the device could be permanently damaged.

Absolute maximum ratings are stress ratings only and functional device operation is not implied.

2. Pulse (μ sec) noise exceeding the above input voltage (GND+7.0V) may cause damage to the IC.

■ THERMAL DATA

PARAMETER	SYMBOL	RATINGS	UNIT
Junction to Ambient	θ_{JA}	59	°C/W
Junction to Case	θ_{JC}	4.5	°C/W

■ RECOMMENDED OPERATING CONDITIONS

PARAMETER	SYMBOL	MIN	TYP	MAX	UNIT
Operating Voltage	V_{IN}	4.5		6.0	V
Programmable Current	I_{CHG}	50		500	mA
Operating Temperature	T_A	-40		85	°C

■ ELECTRICAL CHARACTERISTICS ($V_{CC}=5V$, $T_A=25^\circ C$ unless otherwise specified)

PARAMETER	SYMBOL	TEST CONDITIONS	MIN	TYP	MAX	UNIT
V_{IN} -BAT Offset Voltage Rising Edge	V_{OS}	$V_{BAT}=4.0V$		90	150	mV
V_{IN} -BAT Offset Voltage Falling Edge		$V_{BAT}=4.0V$	10	50		
Rising Power On Reset Threshold	V_{POR}	$V_{BAT}=3.0V$	3.4	3.9	4.3	V
Falling Power On Reset Threshold		$V_{BAT}=3.0V$	3.1	3.6	4.1	
DC Supply Current	I_{DC}	Charge enabled		500	1000	μA
		Charge disabled		300	500	
BAT Pin Sink Current	I_{STBY}	Charge disabled or the input is floating		1		μA
Output Voltage	V_{CH}	$4.5V < V_{IN} < 6.5V$, Charge Current=20mA	4.15	4.20	4.25	V
Power FET "ON" Resistance	$V_{DS(on)}$	$V_{BAT}=3.8V$, Charge Current=0.5A		0.6		Ω
Constant Charge Current for Adaptor Mode	I_{CHG}	$R_{IREF}=29.4k\Omega$, $V_{BAT}=2.8\sim 4.0V$	120	135	150	mA
Precharge Charge Current	I_{PRE}	$R_{IREF}=29.4k\Omega$, $V_{BAT}=2.4V$	17	27	37	mA
End of Charge Current	I_{MIN}	$R_{IMIN}=29.4k\Omega$	17	27	37	mA
EOC Rising Threshold	I_{RECH}	$R_{IMIN}=29.4k\Omega$	70	100	130	mA
Precharge Threshold Voltage	V_{PRE}		2.65	2.75	2.85	V
Precharge Voltage Hysteresis	V_{PREHYS}		40	100	160	mV
Thermal Regulation Threshold	T_{FOLD}			115		°C
EN Pin Logic Input High	V_{ENH}		1.3			V
EN Pin Logic Input Low	V_{ENL}				0.5	
EN Pin Internal pull Down Resistance	R_{EN}		100	200	300	k Ω
CHG Pin Sink Current When Low	I_{CHGOL}	$V_{CHG}=1.0V$	5			mA
CHG Pin Leakage Current When High	I_{CHGOH}	$V_{CHG}=6.5V$			1	μA
PPR Pin Sink Current When Low	I_{PPROL}	$V_{PPR}=1.0V$	5			mA
PPR Pin Leakage Current When High	I_{PPROH}	$V_{PPR}=6.5V$			1	μA

■ OPERATION

The UTC **UB10803** charges a single-cell Li-ion/Polymer battery with a programmed constant current (CC) or a constant voltage (CV) profile. The constant fast charge current I_{CHG} is programmable by setting an external resistor R_{REF} while the constant voltage is factory-trimmed at 4.2V (4.10V or 4.36V options are available upon request). If the battery voltage is deeply discharged to lower than 2.75V, The UTC **UB10803** pre-charges the battery with a 20% programmable current until the battery voltage rises above the pre-charge threshold. After pre-charge finishes, constant-current (CC) charging mode begins with the pre-set fast charge current. Normally, the battery voltage rises gradually during CC charge phase. When the battery voltage reaches nearly 4.2V, the charger enters the constant-voltage (CV) charging mode and begins to regulate the battery voltage at 4.2V while diminishing the charging current gradually. When the charging current is reduced to an amount smaller than the programmed End-Of-Charge (EOC) current level, the charger gives out a “full-charge” indication through the CHG pin, but the charger still continues to regulate the battery voltage at 4.2V with safe & small current.

The end-of-charge (EOC) current level (I_{MIN}) can be easily programmed with an external resistor R_{MIN} . The CHG signal turns to LOW when pre-charge starts and rises to HIGH when EOC is reached. After reaching EOC, the charge current has to rise again to typically 76% of I_{CHG} before the CHG signal will turn on again. The current surge after EOC can be caused by a load connected to the battery.

When the die temperature reaches **115°C** (typically), a thermal regulation function is employed to reduce the charge current accordingly to maintain the temperature from increasing furthermore. This is an important function to achieve safe operation even when the printed circuit board (PCB) is not effective in leaking out the heat generated by the linear charger.

1. PPR Indication

The PPR pin is implemented as an open-drain output to provide a power-good indication of the input power source such as an AC adapter. When the input voltage is higher than the POR (Power-On Reset) threshold, the PPR pin turns on the internal open-drain MOSFET to indicate logic LOW signal. The PPR indication is designed to be independent on the chip enable (EN-pin) input. When the internal open-drain FET is turned off, the PPR pin should leak less than 1 μ A current. When turned on, the PPR pin should be able to sink at least 5mA current under all operating conditions. The PPR pin can be used to drive an LED or worked as logic interface to a microprocessor.

2. Power-Good Range

The input voltage is considered as power good when it meets the following three conditions:

- (1). $V_{IN} > V_{POR}$
- (2). $V_{IN} - V_{BAT} > V_{OS}$

Where the V_{OS} is the offset voltage, it determines if the battery voltage is even higher than the input voltage. All V_{POR} and V_{OS} are realized with sufficient hysteresis, as given in the Electrical Specification table. All charging activities are disabled when the input voltage falls out of the power-good range.

3. Input and Output Comparator

Obviously, when the input source voltage is lower than the battery voltage, no charging activity could be started and the charger will disable the internal pass element to prevent battery leakage. Charge begins when the input voltage is higher than the battery voltage by a defined offset voltage (V_{OS}). This scheme also ensures that the charger is completely turned off when the input power is removed from the charger.

4. CHG Indication

The CHG pin is implemented as an open-drain output to give a logic LOW when a charge cycle begins and turn HIGH when an end-of-charge (EOC) condition is reached. This pin is designed with a sinking ability of more than 5mA so as to drive an LED. When the charger is disabled through EN-pin, the CHG output is high impedance. The CHG pin can also be used to interface with a microprocessor.

5. EN Input

The chip is enabled by a logic LOW signal applied to the EN pin. This pin is realized with a 200k Ω internal pull-down resistor such that even the EN pin is left floating, the input is equivalent to logic LOW and the chip is enabled by default. Similarly, the chip is disabled when the EN pin receives a logic HIGH signal.

■ OPERATION(Cont.)

6. I_{MIN} Indication

The I_{MIN} pin can be used to program the End-of-Charge (EOC) current by connecting a resistor between this pin and the GND pin. The programming is defined by the following equation:

$$I_{\text{MIN}}(\text{mA}) = \frac{800}{R_{\text{IMIN}}}$$

Where R_{IMIN} is usually in kΩ.

7. I_{REF} Pin

The I_{REF} pin is for fast charge-current programming. By connecting a resistor between this pin and the GND pin, the fast charge current limit is determined by the following equation:

$$I_{\text{CHG}}(\text{mA}) = \frac{4000}{R_{\text{IREF}}}$$

Where R_{IREF} is in kΩ. The actual charge current is guaranteed to have 10% accuracy of I_{CHG} with the charge current set at 150mA.

8. BAT pin

Always connect the BAT pin to a single-cell Li-ion/Polymer battery in parallel with a 1μF (or larger) X5R ceramic capacitor for decoupling and guaranteeing system stability. When the EN pin is pulled to logic HIGH, the BAT output is disabled. The UTC **UB10803** relies on a battery for stability and is not guaranteed to be stable if the battery is not connected.

9. Dropout Voltage

When the input voltage is low while the battery voltage is high, the charging current may not be maintained according to the equation I_{CHG} (mA) = 4000/R_{IREF} due to a limited internal on-resistance (R_{DS(ON)}) of the internal pass element. The worst resistance of the pass FET is about 1.2Ω at the maximum operating temperature, thus if tested with 500mA current and 4.2V battery voltage, constant current could still be maintained when the input voltage is as low as 4.62V.

10. Thermal Foldback

The bottom big exposed pads in both HSOP-8 and DFN-8(2x3) packages are used for thermal foldback. For reducing the chip ambient temperature as much as possible, it is recommended to connect as much copper as possible to this pad either on the component layer or other layers through thermal vias. The thermal regulation function starts to reduce the charge current when the internal temperature reaches a typical value of 115°C.

■ APPLICATION INFORMATION

Input Capacitor Selection

The input capacitor is employed to decouple the power supply from load transients and suppress noise from power lines. Typically, a 1 μ F X5R ceramic capacitor is recommended to be placed very close between the V_{IN} pin and GND pin to stabilize the operation during the start up, especially when the input supply is passing the POR threshold and the V_{IN} -BAT comparator offset voltage. Once passing through the POR threshold, there is a voltage hysteresis to provide sufficient guard band from noise or load transient to trigger the system to reset.

Output Capacitor Selection

The criterion for selecting the output capacitor is to maintain the stability of the charger as well as to bypass any transient load current. Typically, a minimum capacitance of 1 μ F X5R ceramic capacitor is recommended and sufficient for stabilizing the system. For systems that may happen to occasionally see high load transients, the output capacitor may be increased to further bypass any ripples so caused.

Charge Current Limit

During the constant-current (CC) charging mode, the charging current is primarily determined by I_{CHG} as calculated in previous formula. However, the actual charge current in the CC mode could also be limited by other factors. When the input (V_{IN}) and output (V_{BAT}) voltages are too close to each other, the on-resistance of the internal pass element may limit the amount of current that passes through it.

When the input voltage is sufficiently higher than the battery voltage, yet has not increased the die temperature over the thermal limit.

When the input voltage is reduced (or the battery voltage increases towards the input voltage), the charge current is limited by the on-resistance of the pass element. Therefore, it is recommended to employ sufficiently high input voltage for applications that require constant charging current over the entire charging period. But for applications that needs to minimize the heat dissipation, a current-limiting adapter maybe applied to maintain constant charging current at whole charging phase.

In addition, if the input voltage increases, the charge current may also be reduced due to the thermal fold back function. The high voltage drop across the pass element increases the power dissipation therein and thus causing the die temperature to increase significantly.

Layout Guidance

The UTC **UB10803** employs thermally-enhanced DFN package, which has an exposed thermal pad at its bottom side. It is recommended to connect as much copper as possible between the exposed pad and PCB to make it effective in taking the heat away from the die. For applications requiring high charging current, the thermal impedance should be further reduced by employing more layers of copper to connect with the exposed pad through thermal via.

Input Power Sources

The UTC **UB10803** works with different types of AC/DC adapter or USB port (any type) with no special requirements. The UTC **UB10803** accepts input voltage ranges from 4.5V to 6.5V for normal operation.

■ TYPICAL CHARGE PROFILE

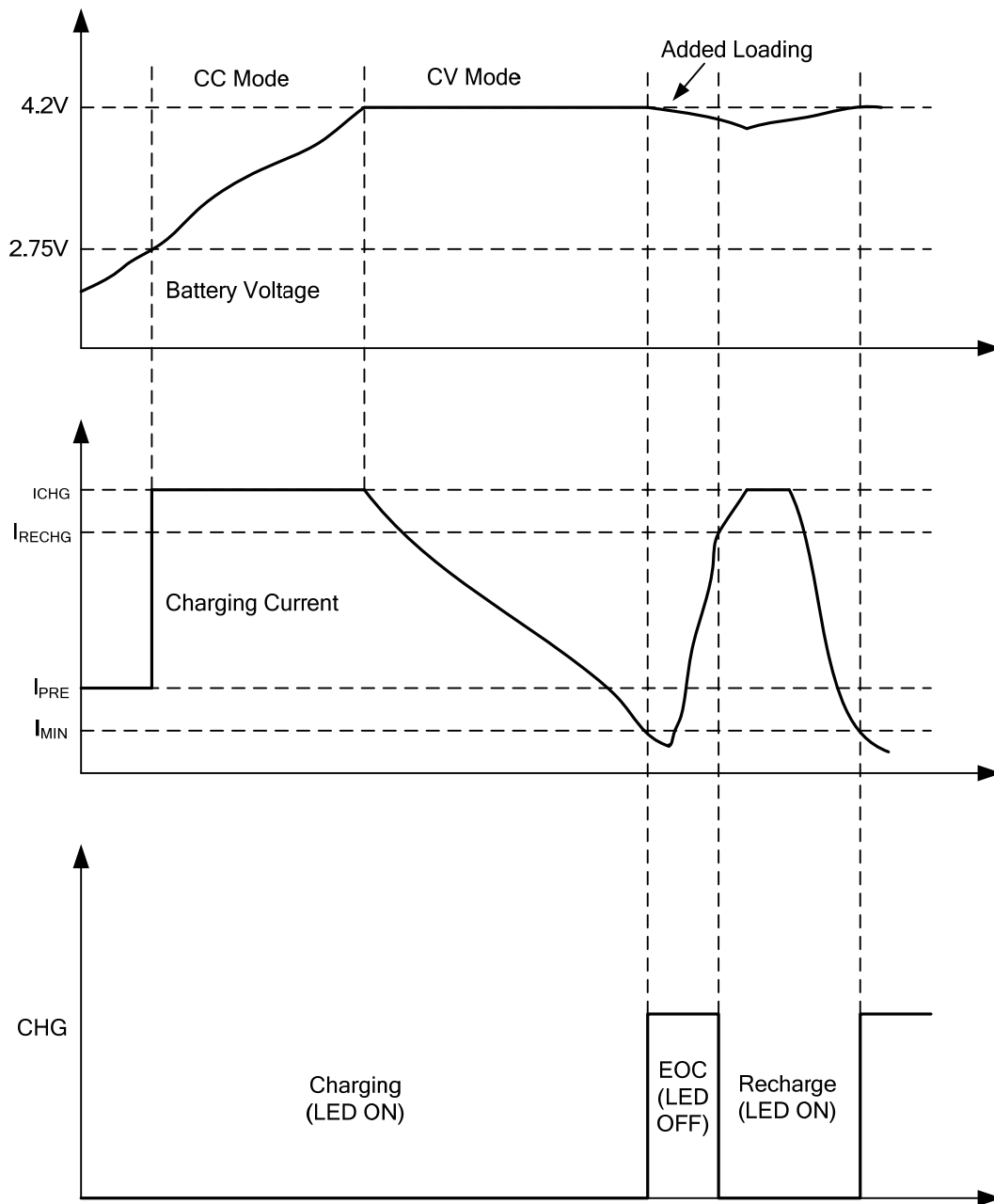

FLYING 汎翔國際有限公司
www.flying1688.com

■ TYPICAL APPLICATION CIRCUIT

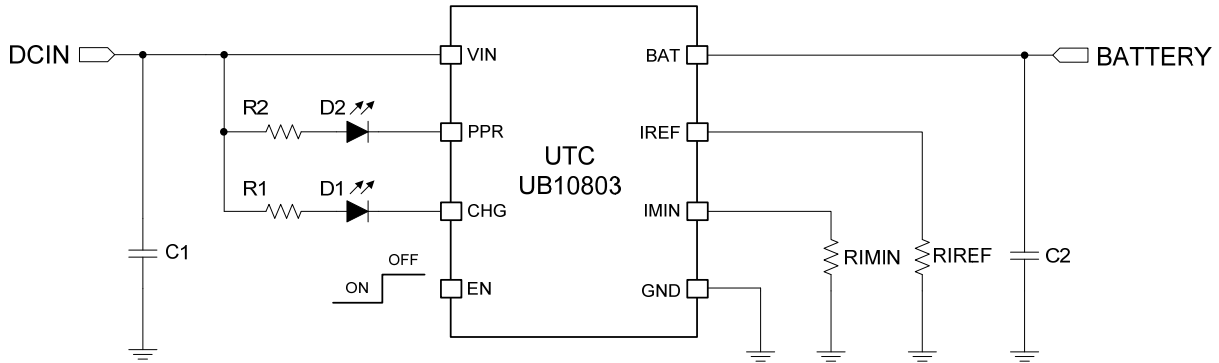

Fig1. Typical Application Circuit for LED Display

Component Description for Figure 1

Part	Description
C1	1µF X5R ceramic cap
C2	1µF X5R ceramic cap
R1REF	29.4kΩ, 1% for 135mA charge current
R1MIN	29.4kΩ, 1% for 27mA EOC current
R1, R2	300Ω, 5%
D1, D2	LEDs for indication

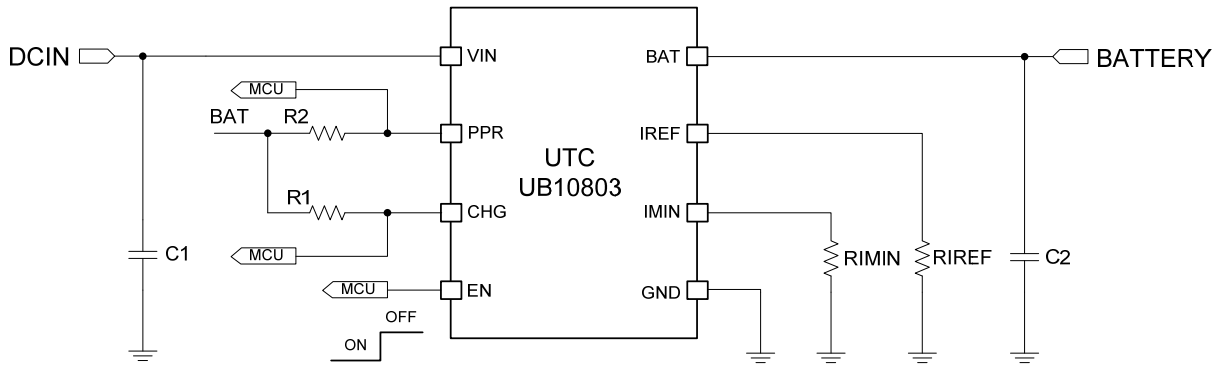

Fig2. Typical Application Circuit Interfacing to a MCU

Component Description for Figure 2

Part	Description
C1	1µF X5R ceramic cap
C2	1µF X5R ceramic cap
R1REF	29.4kΩ, 1% for 135mA charge current
R1MIN	29.4kΩ, 1% for 27mA EOC current
R1, R2	100kΩ, 5%

UTC assumes no responsibility for equipment failures that result from using products at values that exceed, even momentarily, rated values (such as maximum ratings, operating condition ranges, or other parameters) listed in products specifications of any and all UTC products described or contained herein. UTC products are not designed for use in life support appliances, devices or systems where malfunction of these products can be reasonably expected to result in personal injury. Reproduction in whole or in part is prohibited without the prior written consent of the copyright owner. The information presented in this document does not form part of any quotation or contract, is believed to be accurate and reliable and may be changed without notice.