



## UF02P10

Power MOSFET

### -0.2A, -100V P-CHANNEL POWER MOSFET

#### DESCRIPTION

The UTC **UF02P10** is a P-channel power MOSFET using UTC's advanced technology to provide the customers with high switching speed, cost-effectiveness and a minimum on-state resistance. It can also withstand high energy in the avalanche.

#### FEATURES

- \*  $R_{DS(ON)} \leq 6.0\Omega$  @  $V_{GS}=-10V$ ,  $I_D=-0.1A$
- \* Low capacitance
- \* Low gate charge
- \* Fast switching capability
- \* Avalanche energy specified

#### SYMBOL

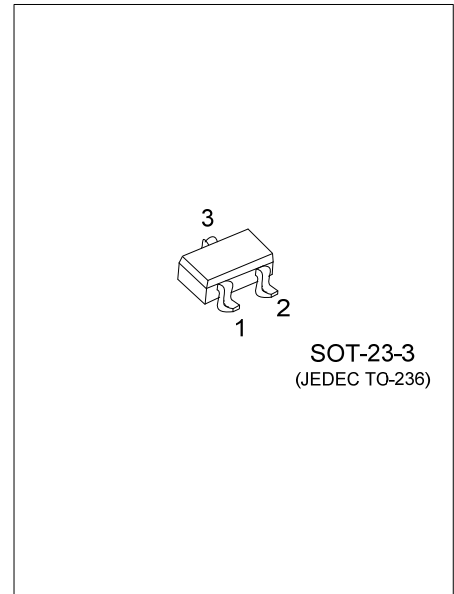
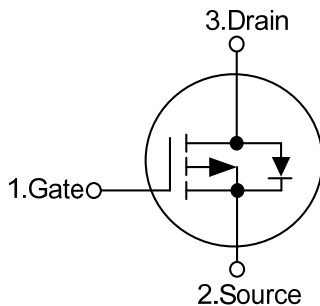

#### ORDERING INFORMATION

Ordering Number		Package	Pin Assignment			Packing
Lead Free	Halogen Free		1	2	3	
UF02P10L-AE2-R	UF02P10G-AE2-R	SOT-23-3	G	S	D	Tape Reel

Note: Pin Assignment: G: Gate S: Source D: Drain

<p>UF02P10G-AE2-R</p> <p>(1)Packing Type</p> <p>(2)Package Type</p> <p>(3)Green Package</p>	<p>(1) R: Tape Reel</p> <p>(2) AE2: SOT-23-3</p> <p>(3) G: Halogen Free and Lead Free, L: Lead Free</p>
---------------------------------------------------------------------------------------------	---------------------------------------------------------------------------------------------------------

#### MARKING

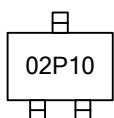

■ ABSOLUTE MAXIMUM RATINGS ( $T_C=25^{\circ}\text{C}$ , unless otherwise specified)

PARAMETER	SYMBOL	RATINGS	UNIT
Drain-Source Voltage	$V_{DSS}$	-100	V
Gate-Source Voltage	$V_{GSS}$	$\pm 20$	V
Continuous Drain Current	$I_D$	-0.2	A
Pulsed Drain Current (Note 2)	$I_{DM}$	-0.8	A
Power Dissipation	$P_D$	0.3	W
Junction Temperature	$T_J$	+150	$^{\circ}\text{C}$
Storage Temperature	$T_{STG}$	-55 ~ +150	$^{\circ}\text{C}$

Notes: 1. Absolute maximum ratings are those values beyond which the device could be permanently damaged. Absolute maximum ratings are stress ratings only and functional device operation is not implied.  
2. Repetitive Rating: Pulse width limited by maximum junction temperature.

■ THERMAL CHARACTERISTICS

PARAMETER	SYMBOL	RATING	UNIT
Junction to Ambient	$\theta_{JA}$	325	$^{\circ}\text{C}/\text{W}$
Junction to Case	$\theta_{JC}$	110	$^{\circ}\text{C}/\text{W}$

■ ELECTRICAL CHARACTERISTICS ( $T_C=25^{\circ}\text{C}$ , unless otherwise specified)

PARAMETER	SYMBOL	TEST CONDITIONS	MIN	TYP	MAX	UNIT
<b>OFF CHARACTERISTICS</b>						
Drain-Source Breakdown Voltage	$BV_{DSS}$	$V_{GS}=0\text{V}, I_D=-250\mu\text{A}$	-100			V
Drain-Source Leakage Current	$I_{DSS}$	$V_{DS}=-100\text{V}, V_{GS}=0\text{V}$			-1	$\mu\text{A}$
Gate-Source Leakage Current	$I_{GSS}$	$V_{DS}=0\text{V}, V_{GS}=\pm 20\text{V}$			$\pm 100$	nA
<b>ON CHARACTERISTICS</b>						
Gate Threshold Voltage	$V_{GS(TH)}$	$V_{DS}=V_{GS}, I_D=-250\mu\text{A}$	-2.0		-4.0	V
Static Drain-Source On-Resistance	$R_{DS(ON)}$	$V_{GS}=-10\text{V}, I_D=-0.1\text{A}$			6.0	$\Omega$
<b>DYNAMIC PARAMETERS</b>						
Input Capacitance	$C_{ISS}$	$V_{DS}=-25\text{V}, V_{GS}=0\text{V}, f=1.0\text{MHz}$		110		pF
Output Capacitance	$C_{OSS}$			16		pF
Reverse Transfer Capacitance	$C_{RSS}$			5		pF
<b>SWITCHING PARAMETERS</b>						
Total Gate Charge	$Q_G$	$V_{DS}=-50\text{V}, V_{GS}=-10\text{V}, I_D=-0.5\text{A}$ $I_G=-100\mu\text{A}$ (Note 1, 2)		7.5		nC
Gate Source Charge	$Q_{GS}$			1.1		nC
Gate Drain Charge	$Q_{GD}$			0.6		nC
Turn-ON Delay Time	$t_{D(ON)}$	$V_{DD}=-30\text{V}, V_{GS}=-10\text{V}, I_D=-0.5\text{A}$ $R_G=25\Omega$ (Note 1, 2)		26		ns
Turn-ON Rise Time	$t_R$			26		ns
Turn-OFF Delay Time	$t_{D(OFF)}$			46		ns
Turn-OFF Fall-Time	$t_F$			36		ns
<b>SOURCE- DRAIN DIODE RATINGS AND CHARACTERISTICS</b>						
Maximum Continuous Drain-Source Diode Forward Current	$I_S$				-0.2	A
Maximum Pulsed Drain-Source Diode Forward Current	$I_{SM}$				-0.8	A
Diode Forward Voltage	$V_{SD}$	$V_{GS}=0\text{V}, I_S=-0.8\text{A}$			-2.0	V

Notes: 1. Pulse Test : Pulse width  $\leq 300\mu\text{s}$ , Duty cycle  $\leq 2\%$ .  
2. Essentially independent of operating temperature.

■ TEST CIRCUITS AND WAVEFORMS

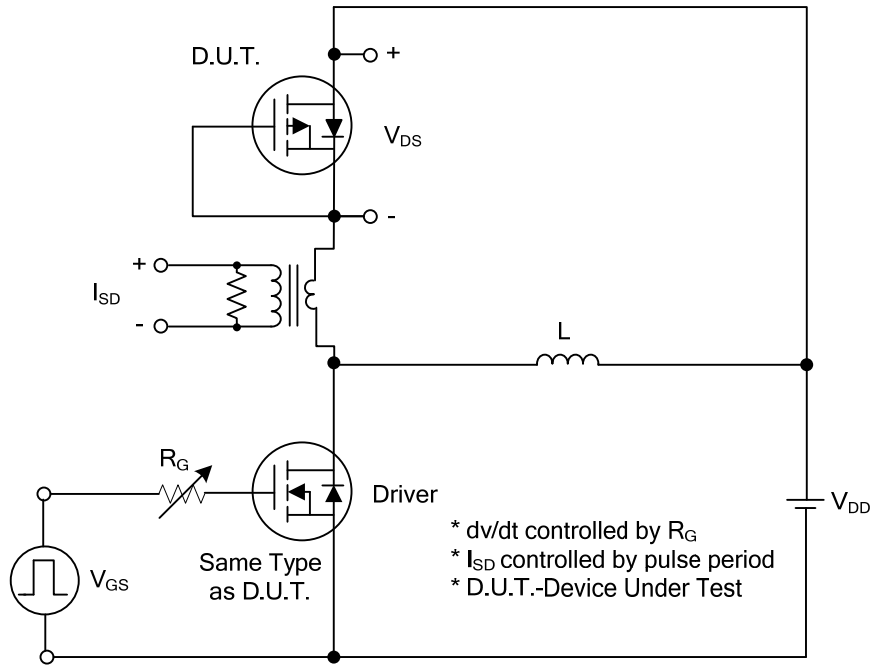

Peak Diode Recovery  $dv/dt$  Test Circuit

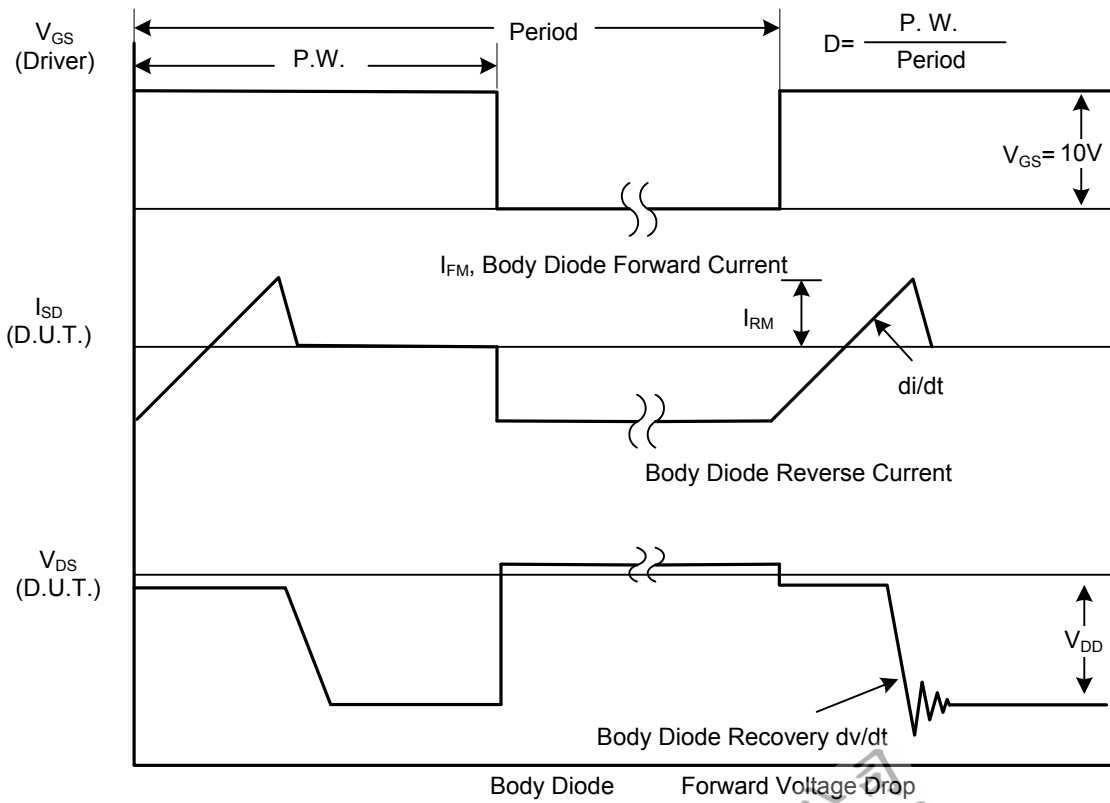

Peak Diode Recovery  $dv/dt$  Waveforms

## TEST CIRCUITS AND WAVEFORMS

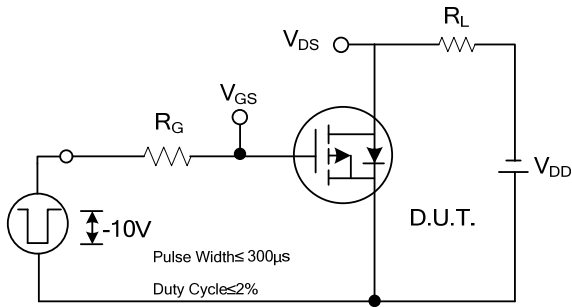

**Switching Test Circuit**

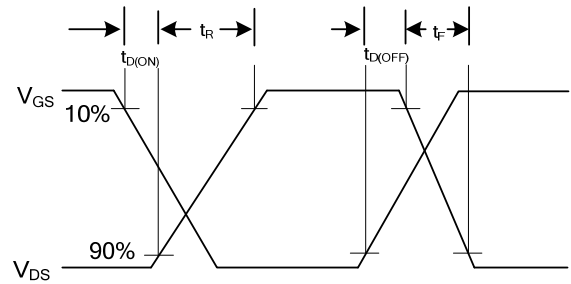

**Switching Waveforms**

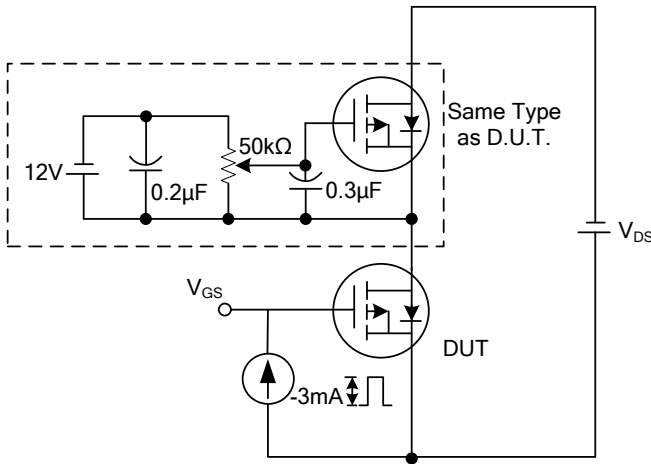

**Gate Charge Test Circuit**

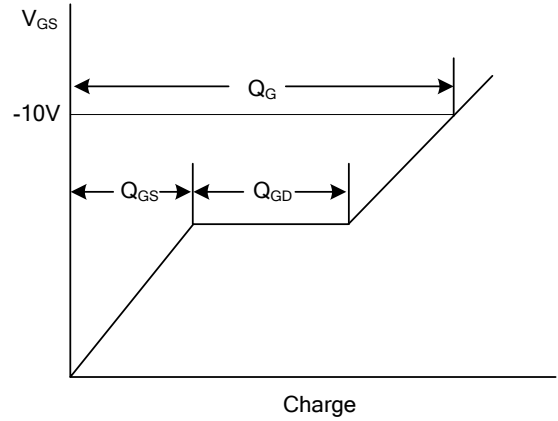

**Gate Charge Waveform**

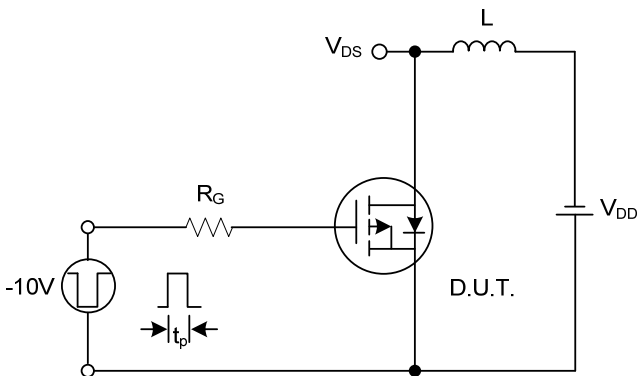

**Unclamped Inductive Switching Test Circuit**

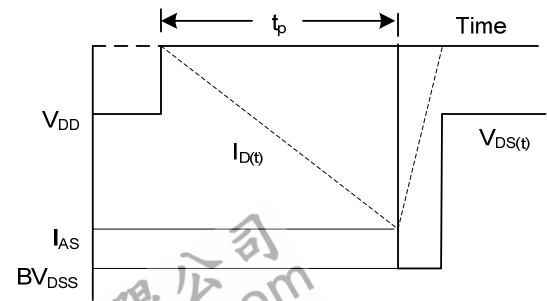

**Unclamped Inductive Switching Waveforms**

UTC assumes no responsibility for equipment failures that result from using products at values that exceed, even momentarily, rated values (such as maximum ratings, operating condition ranges, or other parameters) listed in products specifications of any and all UTC products described or contained herein. UTC products are not designed for use in life support appliances, devices or systems where malfunction of these products can be reasonably expected to result in personal injury. Reproduction in whole or in part is prohibited without the prior written consent of the copyright owner. UTC reserves the right to make changes to information published in this document, including without limitation specifications and product descriptions, at any time and without notice. This document supersedes and replaces all information supplied prior to the publication hereof.