



UFZ44

Power MOSFET

50 A, 60 V N-CHANNEL POWER MOSFET

DESCRIPTION

The UTC **UFZ44** is an N-channel mode Power MOSFET, using UTC's advanced technology to provide customers with a minimum on-state resistance, superior switching performance, cost-effectiveness and ruggedized device design.

FEATURES

- * $R_{DS(ON)} < 28m\Omega @ V_{GS}=10V, I_D=31A$
- * High Switching Speed
- * Improved dv/dt Capability

SYMBOL

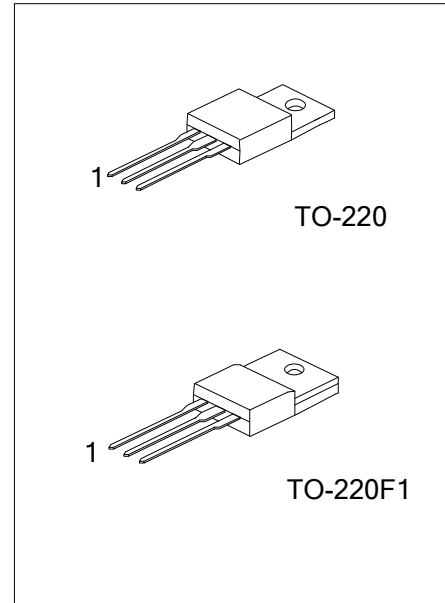
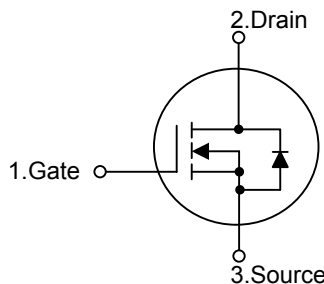

ORDERING INFORMATION

Ordering Number		Package	Pin Assignment			Packing
Lead Free	Halogen Free		1	2	3	
UFZ44L-TA3-T	UFZ44G-TA3-T	TO-220	G	D	S	Tube
UFZ44L-TF1-T	UFZ44G-TF1-T	TO-220F1	G	D	S	Tube

Note: Pin Assignment: G: Gate D: Drain S: Source

<p>UFZ44L-TA3-T</p> <p>(1)Packing Type</p> <p>(2)Package Type</p> <p>(3)Green Package</p>	<p>(1) T: Tube</p> <p>(2) TA3: TO-220, TF1: TO-220F1</p> <p>(3) L: Lead Free, G: Halogen Free and Lead Free</p>
---	---

MARKING

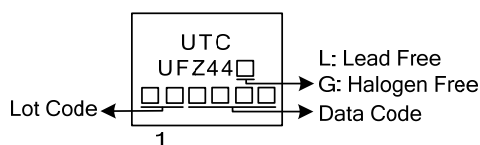

■ ABSOLUTE MAXIMUM RATINGS ($T_C=25^\circ\text{C}$, unless otherwise specified)

PARAMETER		SYMBOL	RATINGS	UNIT	
Drain-Source Voltage		V_{DSS}	60	V	
Gate-Source Voltage		V_{GSS}	± 20	V	
Drain Current	Continuous, V_{GS} at 10V	I_D	$T_C=25^\circ\text{C}$ (Note 2)	50	A
			$T_C=100^\circ\text{C}$	36	A
	Pulsed (Note 3)		I_{DM}	200	A
Single Pulsed Avalanche Energy (Note 4)		E_{AS}	100	mJ	
Peak Diode Recovery dv/dt (Note 5)		dv/dt	4.5	V/ns	
Power Dissipation	$T_C=25^\circ\text{C}$	P_D	TO-220	150	W
			TO-220F1	70	W
Linear De-rating Factor			1.0	W/ $^\circ\text{C}$	
Junction Temperature		T_J	150	$^\circ\text{C}$	
Storage Temperature		T_{STG}	-55~+150	$^\circ\text{C}$	

Notes: 1. Absolute maximum ratings are those values beyond which the device could be permanently damaged.

Absolute maximum ratings are stress ratings only and functional device operation is not implied.

2. Current limited by the package, (die current = 51 A).
3. Repetitive rating; pulse width limited by maximum junction temperature.
4. $V_{DD} = 25\text{ V}$, starting $T_J = 25\text{ }^\circ\text{C}$, $L = 44\text{ }\mu\text{H}$, $R_G = 25\text{ }\Omega$, $I_{AS} = 51\text{ A}$.
5. $I_{SD} \leq 51\text{ A}$, $di/dt \leq 250\text{ A}/\mu\text{s}$, $V_{DD} \leq V_{DS}$, $T_J \leq 175\text{ }^\circ\text{C}$.

■ THERMAL DATA

PARAMETER		SYMBOL	RATINGS	UNIT
Junction to Ambient	TO-220/TO-220F1	θ_{JA}	62	$^\circ\text{C}/\text{W}$
Junction to Case	TO-220	θ_{JC}	1.0	$^\circ\text{C}/\text{W}$
	TO-220F1		1.78	$^\circ\text{C}/\text{W}$

■ ELECTRICAL CHARACTERISTICS (T_J=25°C, unless otherwise specified)

PARAMETER	SYMBOL	TEST CONDITIONS	MIN	TYP	MAX	UNIT
OFF CHARACTERISTICS						
Drain-Source Breakdown Voltage	BV _{DSS}	I _D =250μA, V _{GS} =0V	60			V
Breakdown Voltage Temperature Coefficient	ΔBV _{DSS} /ΔT _J	Reference to 25°C, I _D =1mA		0.060		V/°C
Drain-Source Leakage Current	I _{DSS}	V _{DS} =60V, V _{GS} =0V			25	μA
		V _{DS} =48V, V _{GS} =0V, T _J =125°C			250	
Gate- Source Leakage Current	Forward	V _{GS} =+20V			+100	nA
	Reverse	V _{GS} =-20V,			-100	nA
ON CHARACTERISTICS						
Gate Threshold Voltage	V _{GS(TH)}	V _{DS} =V _{GS} , I _D =250μA	2.0		4.0	V
Static Drain-Source On-State Resistance	R _{DS(ON)}	V _{GS} =10V, I _D =31A (Note 2)			28	mΩ
DYNAMIC PARAMETERS						
Input Capacitance	C _{ISS}	V _{GS} =0V, V _{DS} =25V, f=1.0MHz		1900		pF
Output Capacitance	C _{OSS}			920		pF
Reverse Transfer Capacitance	C _{RSS}			170		pF
SWITCHING PARAMETERS						
Total Gate Charge	Q _G	V _{GS} =10V, V _{DS} =48V, I _D =51A (Note 2)			67	nC
Gate to Source Charge	Q _{GS}				18	nC
Gate to Drain Charge	Q _{GD}				25	nC
Turn-ON Delay Time	t _{D(ON)}	V _{DD} =30V, I _D =51A, R _G =9.1Ω, R _D =0.55 Ω (Note 2)		14		ns
Rise Time	t _R			110		ns
Turn-OFF Delay Time	t _{D(OFF)}			45		ns
Fall-Time	t _F			92		ns
Internal Drain Inductance	L _D	Between lead, 6 mm (0.25") from package and center of die contact			4.5	nH
Internal Source Inductance	L _S				7.5	nH
SOURCE-DRAIN DIODE RATINGS AND CHARACTERISTICS						
Maximum Body-Diode Continuous Current	I _S	MOSFET symbol showing the integral reverse p - n junction diode			50	A
Maximum Body-Diode Pulsed Current	I _{SM}				200	A
Drain-Source Diode Forward Voltage	V _{SD}	I _S =51A, V _{GS} =0V, T _J =25°C(Note 2)			2.5	V
Body Diode Reverse Recovery Time	t _{RR}	I _F =51A, dI/dt=100A/μs, T _J =25°C		120	180	ns
Body Diode Reverse Recovery Charge	Q _{RR}			0.53	0.80	nC
Forward Turn-On Time	t _{ON}	Intrinsic turn-on time is negligible (turn-on is dominated by L _S and L _D)				

Notes: 1. Repetitive Rating: Pulse width limited by maximum junction temperature.

2. Pulse Test: Pulse width ≤ 300μs, Duty cycle ≤ 2%.

TEST CIRCUITS AND WAVEFORMS

Gate Charge Test Circuit

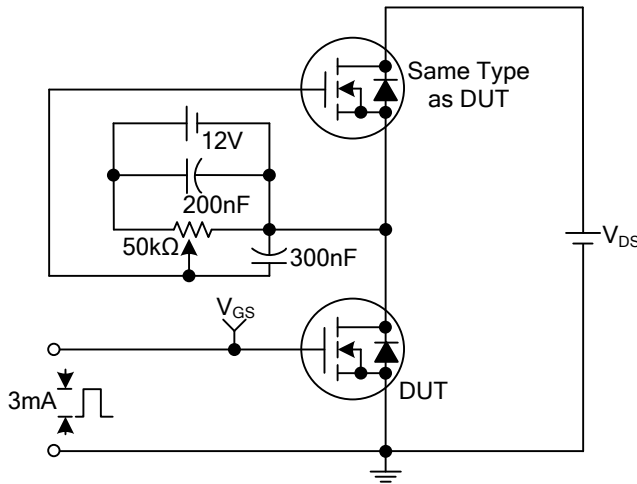

Gate Charge Waveforms

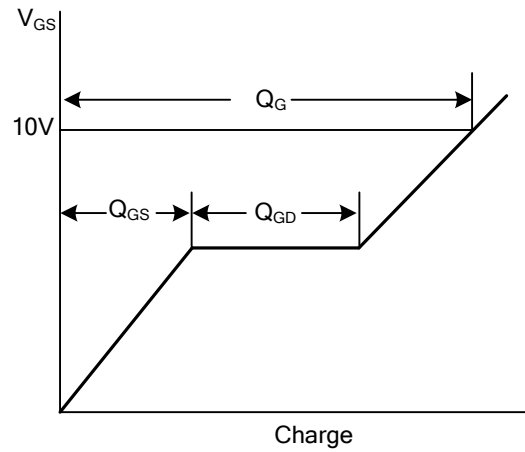

Resistive Switching Test Circuit

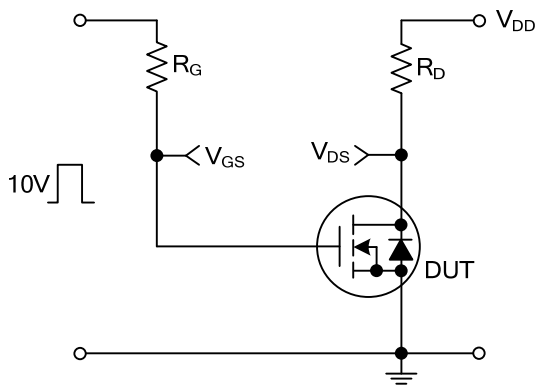

Resistive Switching Waveforms

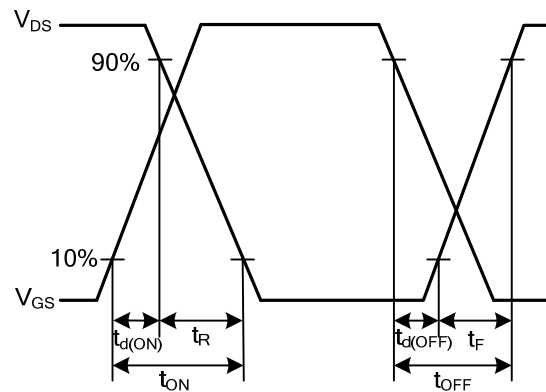

Unclamped Inductive Switching Test Circuit

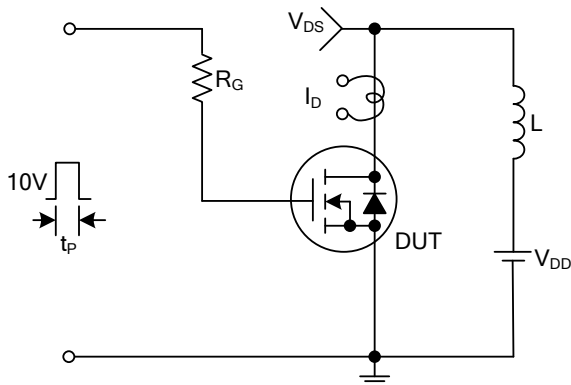

Unclamped Inductive Switching Waveforms

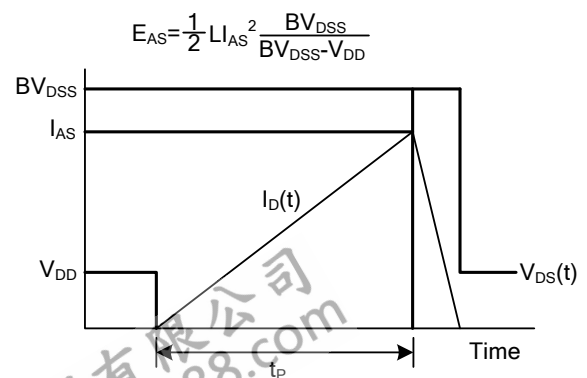

■ TEST CIRCUITS AND WAVEFORMS(Cont.)

Peak Diode Recovery dv/dt Test Circuit & Waveforms

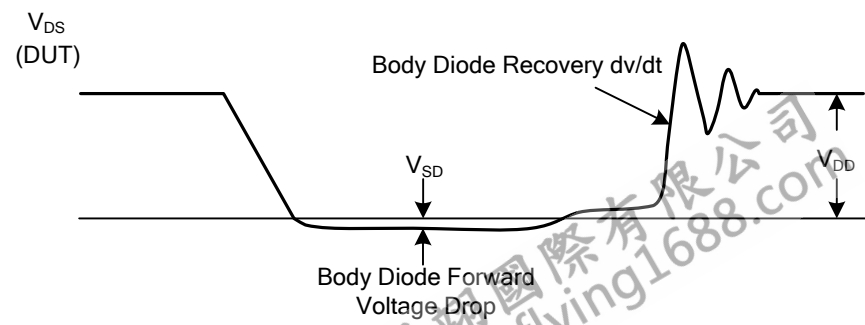
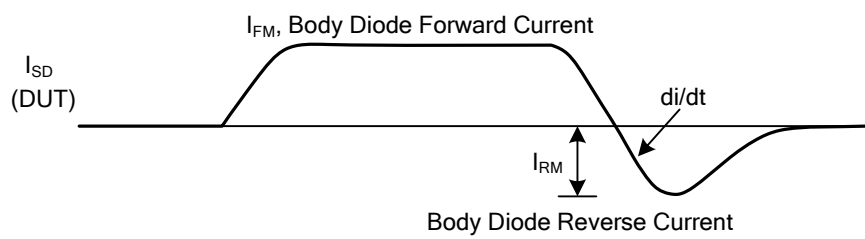
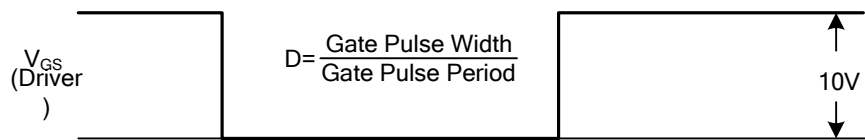
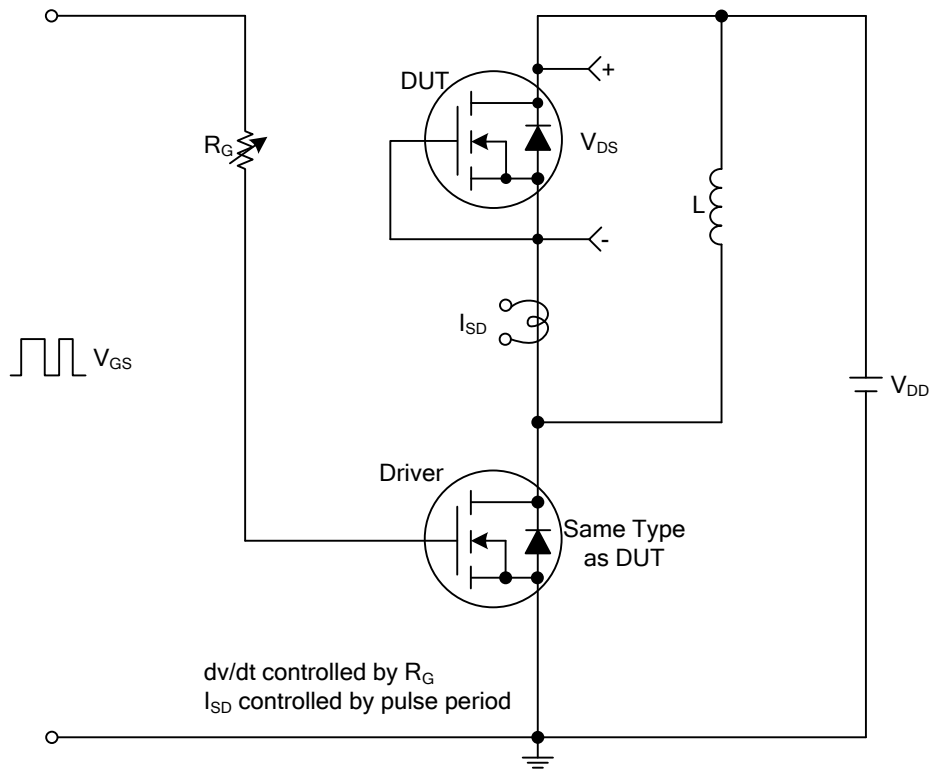

TYPICAL CHARACTERISTICS

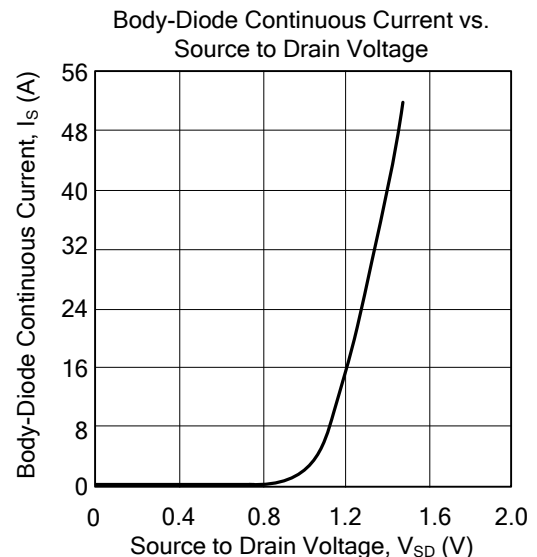
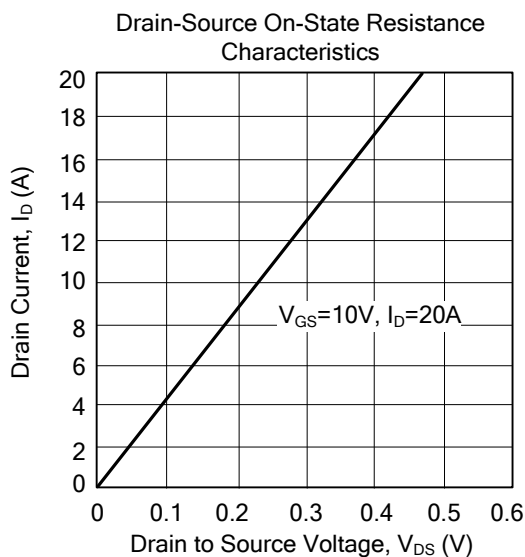
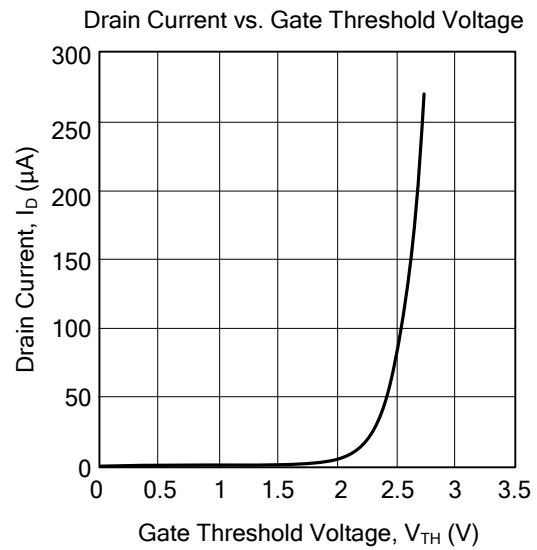
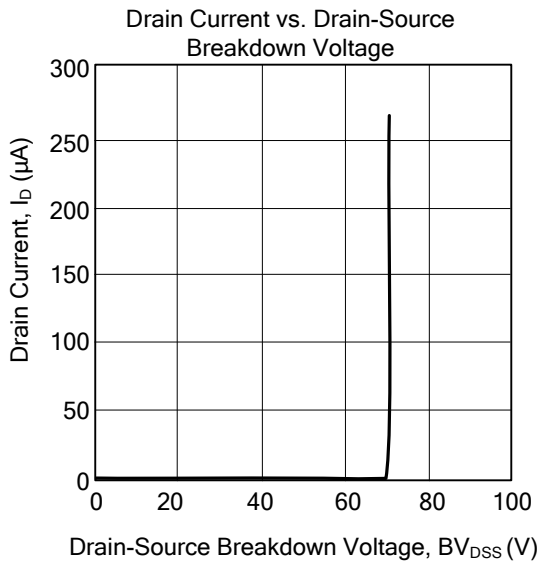

UTC assumes no responsibility for equipment failures that result from using products at values that exceed, even momentarily, rated values (such as maximum ratings, operating condition ranges, or other parameters) listed in products specifications of any and all UTC products described or contained herein. UTC products are not designed for use in life support appliances, devices or systems where malfunction of these products can be reasonably expected to result in personal injury. Reproduction in whole or in part is prohibited without the prior written consent of the copyright owner. The information presented in this document does not form part of any quotation or contract, is believed to be accurate and reliable and may be changed without notice.