



UG8J

NPN SILICON TRANSISTOR

EMITTER COMMON (DUAL DIGITAL TRANSISTORS)

FEATURES

- * Two DTC143Z chips in a SOT-353 package.
- * Mounting cost and area can be cut in half.

STRUCTURE

- * Epitaxial planar type
- * NPN silicon transistor (Built-in resistor type)

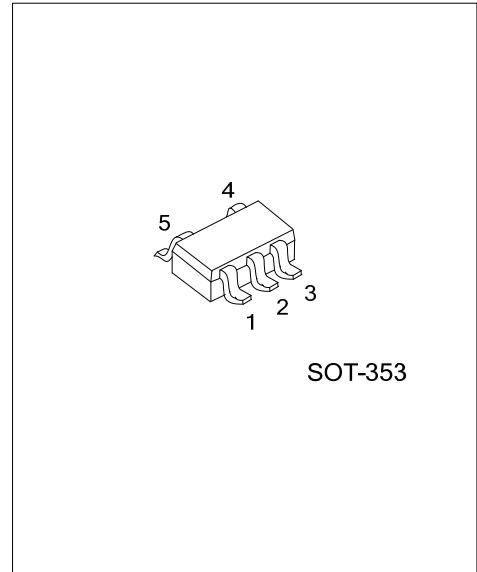

ORDERING INFORMATION

Order Number	Package	Pin Assignment					Packing
		1	2	3	4	5	
UG8JG-AL5-R	SOT-353	B1	E1,E2	B2	C2	C1	Tape Reel

<p>UG8JG-AL5-R</p> <p>(1) Packing Type (2) Package Type (3) Green Package</p>	<p>(1) R: Tape Reel (2) AL5: SOT-353 (3) G: Halogen Free and Lead Free</p>
---	--

MARKING

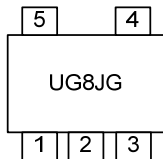

■ ABSOLUTE MAXIMUM RATING ($T_A=25^{\circ}\text{C}$, unless otherwise specified)

PARAMETER	SYMBOL	RATINGS	UNIT
Supply Voltage	V_{CC}	50	V
Input Voltage	V_{IN}	30	V
		5	
Output Current	I_{OUT}	100	mA
	$I_{C(MAX)}$	100	
Total Power Dissipation	P_D	150 (Note1)	mW
Junction Temperature	T_J	+150	$^{\circ}\text{C}$
Storage Temperature	T_{STG}	-40 ~ +150	$^{\circ}\text{C}$

Note: 1. 120mW per element must not be exceeded.

2. Absolute maximum ratings are those values beyond which the device could be permanently damaged.
Absolute maximum ratings are stress ratings only and functional device operation is not implied.

■ ELECTRICAL CHARACTERISTICS ($T_A=25^{\circ}\text{C}$, unless otherwise specified)

PARAMETER	SYMBOL	TEST CONDITIONS	MIN	TYP	MAX	UNIT
Input Voltage	$V_{I(OFF)}$	$V_{CC}=5\text{V}, I_{OUT}=100\mu\text{A}$			0.5	V
	$V_{I(ON)}$	$V_{OUT}=0.3\text{V}, I_{OUT}=5\text{mA}$	1.3			
Output Voltage	$V_{O(ON)}$	$I_{OUT}=5\text{mA}, I_{IN}=0.25\text{mA}$		0.1	0.3	V
Input Current	I_{IN}	$V_{IN}=5\text{V}$			1.8	mA
Output Current	$I_{O(OFF)}$	$V_{CC}=50\text{V}, V_{IN}=0\text{V}$			0.5	μA
DC Current Gain	G_I	$V_{OUT}=5\text{V}, I_{OUT}=10\text{mA}$	80			
Transition Frequency	f_T	$V_{CE}=10\text{V}, I_E=-5\text{mA}, f=100\text{MHz}^*$		250		MHz
Input Resistance	R_I		3.29	4.7	6.11	K Ω
Resistance Ratio	R_2/R_1		8	10	12	

Note: *Transition frequency of the device.

■ EQUIVALENT CIRCUIT (The following characteristic apply to both DT_{r1} and DT_{r2})

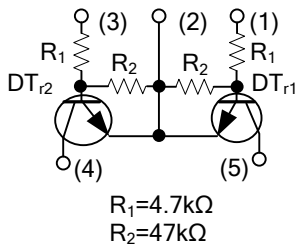

TYPICAL CHARACTERISTICS

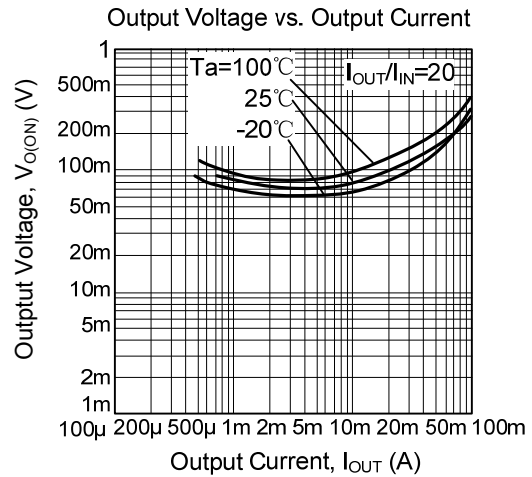
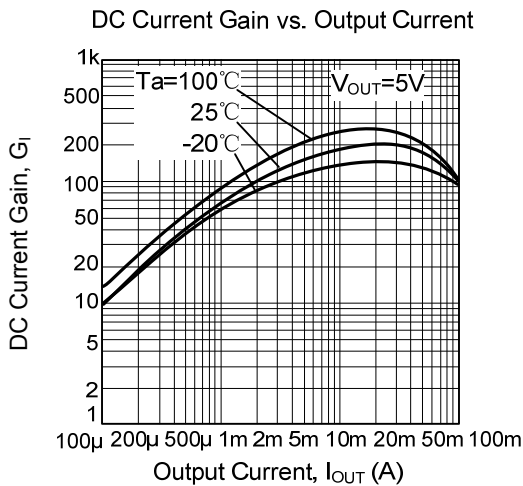
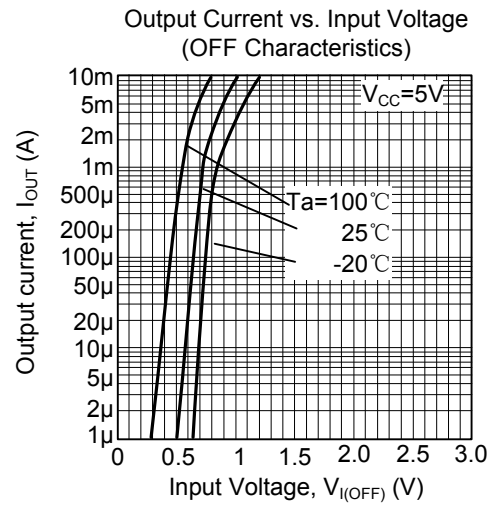
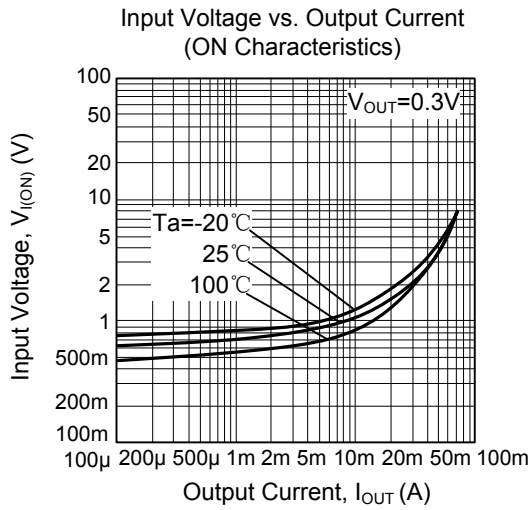

UTC assumes no responsibility for equipment failures that result from using products at values that exceed, even momentarily, rated values (such as maximum ratings, operating condition ranges, or other parameters) listed in products specifications of any and all UTC products described or contained herein. UTC products are not designed for use in life support appliances, devices or systems where malfunction of these products can be reasonably expected to result in personal injury. Reproduction in whole or in part is prohibited without the prior written consent of the copyright owner. The information presented in this document does not form part of any quotation or contract, is believed to be accurate and reliable and may be changed without notice.