



LED DRIVER CONTROLLER

DESCRIPTION

Featured Device, UTC **UL24D**, is a PWM controller with innovative technology. The controller drives a strings of LEDs and can be dimming by an ON/OFF AC wall switch and provides a cost effective solution for light control. It supports power-factor-correction function in applications.

UTC **UL24D** provides several protection features. It includes a cycle-by-cycle current limit to the power switch; over-current protection at the LED load; V_{DD} over-voltage protection. The controller also features an internal over-temperature protection.

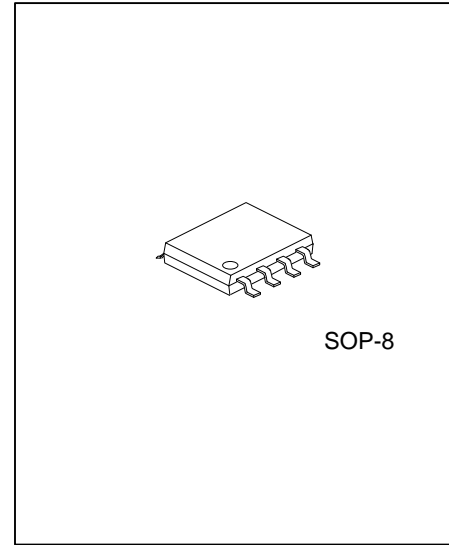

FEATURES

- * Using ON/OFF wall switch to dimming
- * High power factor for high brightness LEDs
- * Low start-up current and operating current
- * Under-voltage lockout (UVLO) with hysteresis
- * Provides complete protection functions
 - Maximum gate driver output clamp
 - V_{DD} pin Over-Voltage Protection
 - Cycle-by-cycle current limit
 - LEDs Over-Current Protection
 - LEDs Open-Loop Protection
 - LEDs Short-Circuit Protection
 - Internal Over-Temperature Protection

ORDERING INFORMATION

Ordering Number		Package	Packing
Lead Free	Halogen Free		
UL24DG-SH2-R	UL24G-SH2-R	SOP-8	Tape Reel

<p>UL24DG-SH2-R</p> <ul style="list-style-type: none"> (1) Packing Type (2) Package Type (3) Green Package 	<ul style="list-style-type: none"> (1) R: Tape Reel (2) SH2: HSOP-8 (3) G: Halogen Free and Lead Free, L: Lead Free
---	--



MARKING

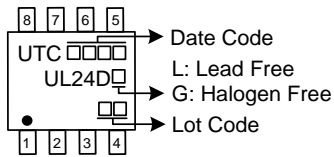

PIN CONFIGURATION

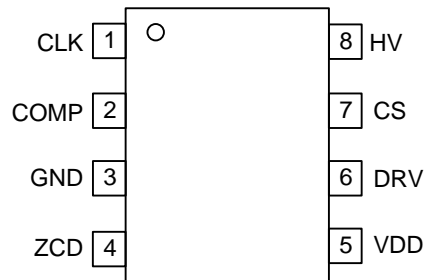

PIN DESCRIPTION

PIN NO.	I/O (Note 1)	PIN NAME	DESCRIPTION
1	I	CLK	Line-voltage detection pin for dimming control.
2	O	COMP	Output of the error amplifier.
3	Power	GND	Power ground.
4	I	ZCD	zero current sense pin.
5	Power	V _{DD}	Power supply.
6	O	DRV	Totem-pole output to drive the external power MOSFET.
7	I	CS	Current sense in series with power switch.
8	Power	HV	Power supply.

Note: I=Input, O=Output

■ BLOCK DIAGRAM

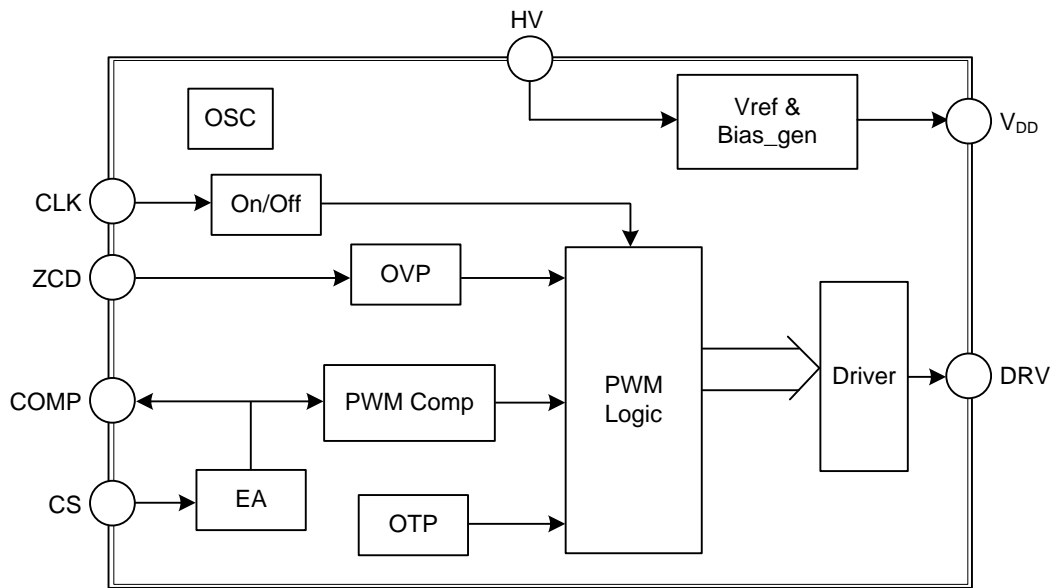

FLYING 汎翔國際有限公司
www.flying1688.com

■ ABSOLUTE MAXIMUM RATING

PARAMETER	SYMBOL	RATINGS	UNIT
Supply Voltage to V _{DD} Pin	V _{DD}	-0.3 ~ 30	V
V _{DD} Maximum Supply Current Limit for OVP Condition	V _{OVP}	20.0	mA
Input Voltage to HV Pin		-0.3 ~ 450	V
Maximum current at ZCD Pin	I _{ZCD}	-10 ~10	mA
Input Voltage to CS Pin	V _{CS}	-0.3 ~ 7.0	V
Input Voltage to CLK Pin	V _{CLK}	-0.3 ~ 7.0	V
Output Voltage at the COMP Pin	V _{COMP}	-0.3 ~ 7.0	V
Maximum Operating Junction Temperature	T _J	+150	°C
Storage Temperature	T _{STG}	-55 ~ +150	°C

Note: Absolute maximum ratings are those values beyond which the device could be permanently damaged. Absolute maximum ratings are stress ratings only and functional device operation is not implied.

■ RECOMMENDED OPERATING RANGE (Note)

PARAMETER	SYMBOL	RATINGS	UNIT
V _{DD} Supply Voltage	V _{DD}	18 ~ 24	V
Operation Ambient Temperature	T _A	-40 ~ +85	°C
Operating Junction Temperature	T _J	+125	°C

■ THERMAL DATA (Note)

PARAMETER	SYMBOL	RATINGS	UNIT
Junction to Ambient	θ _{JA}	50	°C/W
Junction to Case	θ _{JC}	8	°C/W

Note: Not to exceed the maximum junction temperature of the IC, which relates to the operating power of the IC and the thermal resistance of the IC/package as above. The operation power of the IC can be calculated by Pd = V_{DD_IN} × I_{IN}, where V_{DD_IN} represents the input voltage at the V_{DD} pin of the IC and I_{IN} represents the current flow into the V_{DD} pin of the IC.

■ ELECTRICAL CHARACTERISTICS (V_{DD}=18V, T_A=25°C unless otherwise specified)

PARAMETER	SYMBOL	TEST CONDITIONS	MIN	TYP	MAX	UNIT
SUPPLY VOLTAGE (V_{DD} PIN)						
Startup Current	I _{ST}	V _{DD} =10V			20	μA
Operating Current	I _{DD}				3	mA
Turn-on Threshold Voltage	V _{DD-ON}		14.5	15.0	16.5	V
Turn-off Threshold Voltage	V _{DD-OFF}		8.5	9.5	10.5	V
V _{DD} OVP Threshold	V _{DD-OVP}			26		V
Start-up period	T _{ST}			42		μS
INTERNAL OTA						
Reference for Non-Inverting Input	V _{OTAP}	T _A =25°C		252		mV
Over Current Protection Threshold Voltage	V _{OCP}			0.95		V
Over Current Protection Release Threshold Voltage				245		mV
Current limit threshold	V _{CL}			1.1		V
INTERNAL CLK COMPARATOR (CLK PIN)						
Threshold for Line Cycle Detection	V _{CLK-ON}			3		V
ZCD current Detector (ZCD Pin)						
ZCD voltage with 2.5mA Source current	V _{ZCDSE}			0.2		V
ZCD voltage with 2.5mA Sink current	V _{ZCDISK}			3		V
Over voltage protection threshold at ZCD pin	I _{OVP}			305		μA
GATE DRIVE OUTPUT (DRV PIN)						
Rise Time	t _r	C _L =1nF		70		ns
Fall Time	t _f	C _L =1nF		70		ns

FUNCTIONAL DESCRIPTION

Refer to both the Block Diagram in Figure 1 and a reference design circuit in Figure 4 for the following discussions. All parameters mentioned below are typical values.

Start-up Circuit

Applying AC power to the LED driver shown in Figure 4, initiates the operation. During start-up, capacitor C5 is charged up to 15.0V (V_{DD-ON}) through HV pin. The turn-on and turn-off thresholds of the controller are 15.0V and 9.5V (V_{DD-OFF}) respectively. Once the V_{DD} exceeds 15.0V, all of the internal circuits are activated. Referring to Figure 2, the hysteresis voltage for V_{DD} pin is implemented to keep IC operating for a period of time with external hold-up capacitor C5. When V_{DD} drops below 9.5V, the controller shuts off the driver output yet keeping color control function active. The controller will be in shut-off mode with control logic being reset when V_{DD} drops below 4.0V.

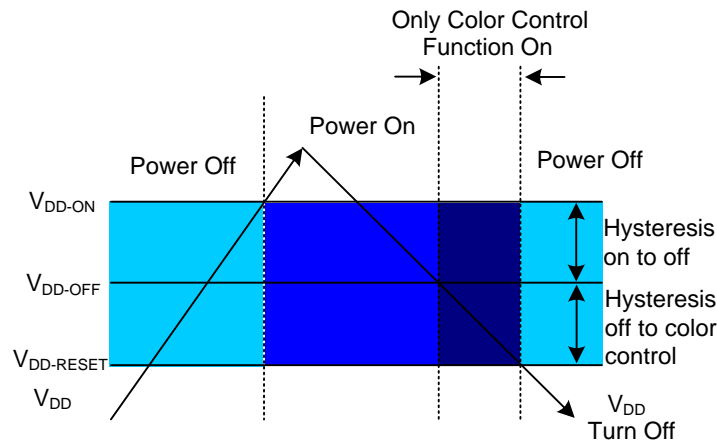

Figure 1. V_{DD} Power Supply Hysteresis

At the beginning of power on, current of LEDs decreases from about 100% to 5% of predefined value in about 7 seconds. Within this period a desired brightness of LEDs can be achieved—by turn off then turn back on wall switch. The current of LEDs at the moment that wall switch turns off will hold until power supply is removed again.

Control

UTC **UL24D** operates with PWM converter operation. It can be used for providing regulated current for high-brightness LED applications. To keep the converter operating under discontinuous mode over various conditions, the primary-side inductance of the power inductor T1 must be designed and operated in Critical Conduction Mode (CRM) at minimum line voltage and maximum load.

During normal operation conditions, current flowing through the LEDs is detected at the sense resistors R6 connected to CS pin. The signal at CS pin is processed to compare with a reference voltage by internal OTA (Operational Transconductance Amplifier) which produces a compensated signal (V_{COMP}) at COMP pin. The compensated signal is then compared with an internal saw-tooth signal to generate a pulse-width-modulation signal for the driver output. When the internal saw-tooth signal intersects with the compensated signal, the switch Q1 will be turned off. Therefore, the COMP pin voltage level determines the turn-on time of power switch and regulates the energy stored in power inductor. The higher level voltage at COMP results in larger duty cycle to the driver which provides higher brightness on LEDs.

Capacitor C4 connected at COMP pin provides a stable close-loop response. The slower the response, the higher power factor converter provides.

CLK pin monitors a divided voltage signal from AC input through resistor divider (R1, R2, R3 and R5 in Figure 4).

The detected thresholds are set at 3V for CLK ON, which can be designed appropriately according to the AC input voltage range.

■ FUNCTIONAL DESCRIPTION (Cont.)**Gate Driver**

The totem-pole DRV output delivers the gate-drive signal to the external power MOSFET..

Leading-Edge Blanking Time

In applications, when MOSFET Q1 is switched on, a current spike may occur at CS pin due to parasitic components in the circuit. The controller employs a built-in filter to ignore the initial 750ns period of each switching cycle at CS signal to avoid the MOSFET being turned off inadvertently.

LED Current Setting

LEDs current sensing resistors R6 connected to CS pin are selected for the LEDs current setting. The LEDs current can be calculated by

$$I_{LED}(\text{mA}) = \frac{252(\text{mV})}{R6(\text{ohm})}$$

Thermal Protection

Thermal protection occurs when the IC experiences a high junction temperature. The MOSFET drive DRV is turned off once the junction temperature exceeds approximately 140°C. It resumes normal operation when the junction temperature drops to or below approximately 110°C.

■ TYPICAL APPLICATION CIRCUIT

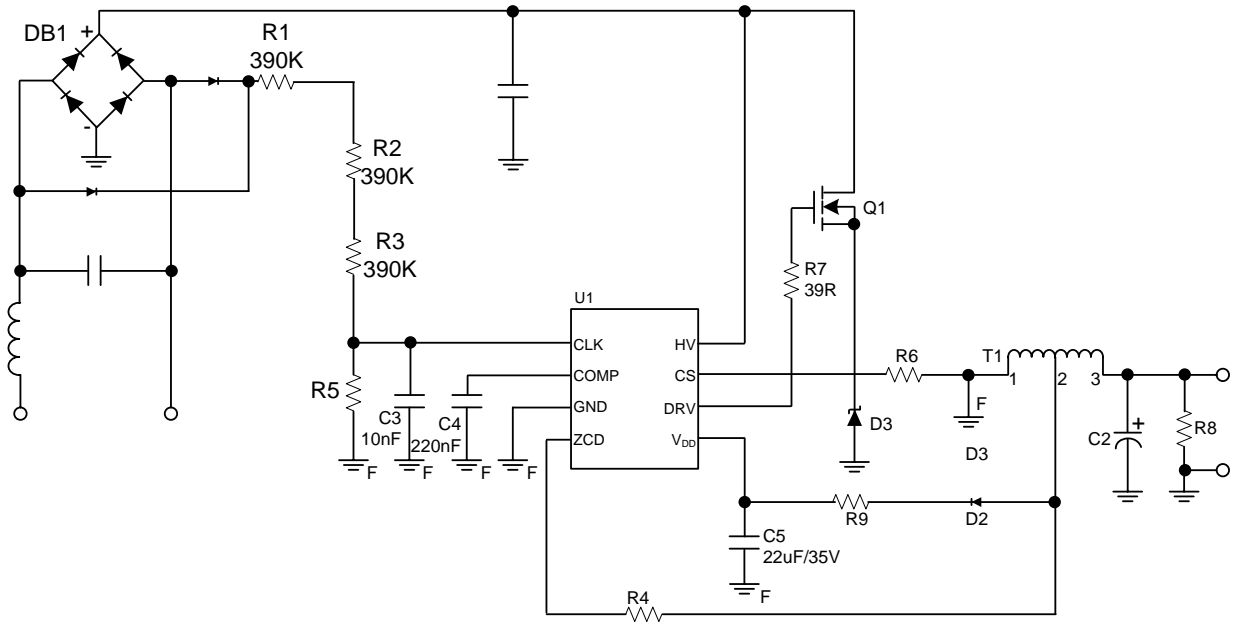

Figure 4

UTC assumes no responsibility for equipment failures that result from using products at values that exceed, even momentarily, rated values (such as maximum ratings, operating condition ranges, or other parameters) listed in products specifications of any and all UTC products described or contained herein. UTC products are not designed for use in life support appliances, devices or systems where malfunction of these products can be reasonably expected to result in personal injury. Reproduction in whole or in part is prohibited without the prior written consent of the copyright owner. UTC reserves the right to make changes to information published in this document, including without limitation specifications and product descriptions, at any time and without notice. This document supersedes and replaces all information supplied prior to the publication hereof.