



## UMD9111

Preliminary

CMOS IC

### BRUSH DC MOTOR DRIVE CIRCUIT

#### DESCRIPTION

UTC **UMD9111** is an integrated brush DC motor drive solution for battery-powered toys, low-voltage or battery-powered motion control applications. It has H bridge driver and uses the PMOS and NMOS power transistors with low output resistance. Low on-resistance ensures the circuit to consume lower power in operating at a continuous current, and ensures the circuit to operate stably for a long time. The circuit has a wide working voltage range, the maximum continuous output current reaches 0.8A, and the maximum peak output current reaches 1.5A.

UTC **UMD9111** has on-chip temperature protection function. When load motor with low internal resistance is in locked rotor, UTC **UMD9111** output current will increase momentarily, power dissipation of the circuit will go up sharply, and the chip temperature will soar. But, when the chip temperature exceeds a maximum temperature point (typically 150°C) set by internal temperature protection circuit, the internal circuit will switch off the on-chip power switching transistor of UTC **UMD9111**, and switch off load current, preventing potential safety hazards such as fuming, igniting, etc. Of plastic package caused by over temperature. Only after having confirmed that the circuit has returned to safety temperature, can the on-chip temperature hysteresis circuit be allowed to re-control the circuit.

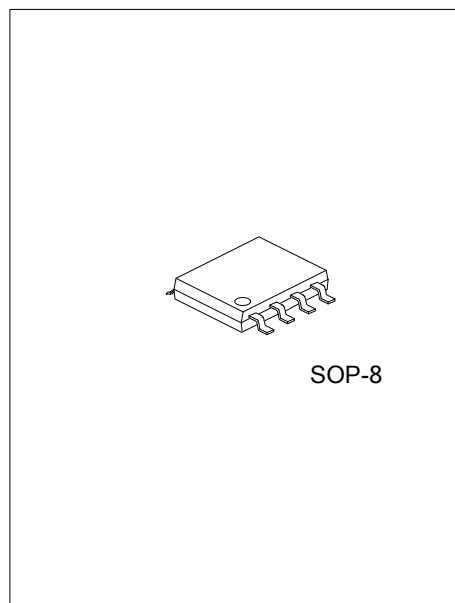

#### FEATURES

- \* H bridge driver of internal PMOS/NMOS power switches
- \* Built-in anti-common state conduction circuit.
- \* Low output impedance
- \* Low standby current (typ.0.1uA)
- \* Low static operational current
- \* On-chip thermal shut down (TSD) with hysteresis

#### ORDERING INFORMATION

Ordering Number		Package	Packing
Lead Free	Halogen Free		
UMD9111L-S08-R	UMD9111G-S08-R	SOP-8	Tape Reel

UMD9111G-S08-R	(1)Packing Type	(1) R: Tape Reel
	(2)Package Type	(2) S08: SOP-8
	(3)Green Package	(3) G: Halogen Free and Lead Free, L: Lead Free

MARKING

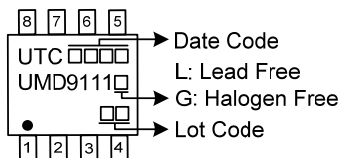

PIN CONFIGURATION

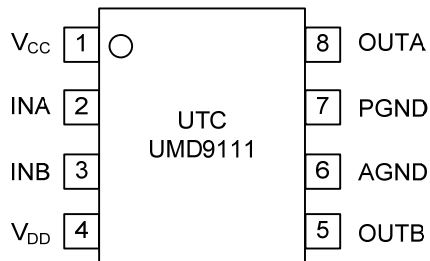

PIN DESCRIPTION

PIN NO.	PIN NAME	DESCRIPTION
1	V <sub>CC</sub>	Power supply of logic control circuit
2	INA	Forward rotation logic input
3	INB	Backward rotation logic input
4	V <sub>DD</sub>	Power supply
5	OUTB	Backward rotation output
6	AGND	Ground of logic control circuit
7	PGND	Ground of output power transistor
8	OUTA	Forward rotation output

■ BLOCK DIAGRAM

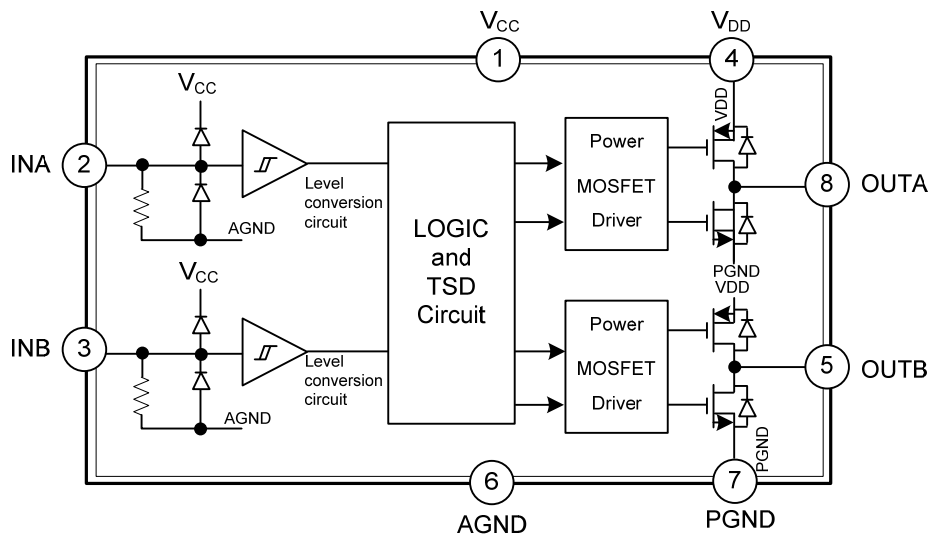

■ LOGIC TRUTH TABLE

INA	INB	OUTA	OUTB	FUNCTION
L	L	Z	Z	Standby (Stop)
H	L	H	L	Forward rotation
L	H	L	H	Backward rotation
H	H	L	L	Brake

FLYING 汎翔國際有限公司  
[www.flying1688.com](http://www.flying1688.com)

■ ABSOLUTE MAXIMUM RATING (T<sub>A</sub>=25°C, unless otherwise specified)

PARAMETER	SYMBOL	RATINGS	UNIT
Maximum Logic and Control Supply Voltage	V <sub>CC</sub>	7	V
Maximum Output Supply Voltage	V <sub>DD</sub>	10	V
Maximum External Output Voltage	V <sub>OUT</sub>	V <sub>DD</sub>	V
Maximum External Input Voltage	V <sub>IN</sub>	V <sub>CC</sub>	V
Peak Output Current/Channel	I <sub>OUT PEAK</sub>	1.5	A
Junction Temperature	T <sub>J</sub>	+150	°C
Operational Temperature Range	T <sub>OPR</sub>	-20 ~ +85	°C
Storage Temperature	T <sub>STG</sub>	-55 ~ +150	°C

Notes: 1. Absolute maximum ratings are those values beyond which the device could be permanently damaged.

Absolute maximum ratings are stress ratings only and functional device operation is not implied.

2. Maximum power dissipation at different ambient can be obtained from the following formula

$$P_D = (T_J - T_A) / \theta_{JA}$$

Where T<sub>J</sub> is junction temperature with the circuit working, and T<sub>A</sub> is the ambient temperature with the circuit working.

3. Method of calculation of circuit power dissipation

$$P = I^2 \times R$$

Where P is circuit power dissipation, I is continuous output current, and R is circuit output on-resistance.

Circuit power dissipation P must be smaller than maximum power dissipation P<sub>D</sub>.

■ THERMAL DATA

PARAMETER	SYMBOL	RATINGS	UNIT
Junction to Ambient	θ <sub>JA</sub>	143	°C/W

■ RECOMMENDED OPERATIONAL CONDITIONS (T<sub>A</sub>=25°C, unless otherwise specified)

PARAMETER	SYMBOL	RATINGS	UNIT
Maximum Logic and Control Supply Voltage	V <sub>CC</sub>	5.0	V
Maximum Output Supply Voltage	V <sub>DD</sub>	9.6	V

Note: Logic control power supply V<sub>CC</sub> and power supply V<sub>DD</sub> are fully separate internally, and can supply electricity separately.

■ ELECTRICAL CHARACTERISTICS (T<sub>A</sub>=25°C, V<sub>CC</sub>=3V, V<sub>DD</sub>=6V, unless otherwise stated)

PARAMETER	SYMBOL	TEST CONDITIONS	MIN	TYP	MAX	UNIT
<b>The Power Supply Parameters</b>						
VCC Standby Current	I <sub>VCCST</sub>	I <sub>NA</sub> =I <sub>NB</sub> =L, V <sub>CC</sub> =7V		0	10	μA
VDD Standby Current	I <sub>VDDST</sub>	V <sub>DD</sub> =10V, Output opened		0	10	μA
VCC Static Supply Current	I <sub>VCC</sub>	I <sub>NA</sub> =H or I <sub>NB</sub> =H: Output opened		182		μA
VDD Static Supply Current	I <sub>VDD</sub>	I <sub>NA</sub> =H or I <sub>NB</sub> =H: Output opened		83		μA
<b>Input Logic Level</b>						
Input High Level	V <sub>INH</sub>		2			V
Input Low Level	V <sub>INL</sub>				0.8	V
Input Level Hysteresis	V <sub>HYS</sub>			0.2		
Input High Level Current	I <sub>INH</sub>	V <sub>INH</sub> =2.5V, V <sub>CC</sub> =3V		191		μA
Input the Pull-Down Resistor	R <sub>IN</sub>	V <sub>INH</sub> =3V, V <sub>CC</sub> =3V		12		kΩ
<b>The Power Tube Leads to Internal Resistance</b>						
Output Resistance	R <sub>ON</sub>	I <sub>O</sub> =±200mA, V <sub>DD</sub> =6V, T <sub>A</sub> =25°C		0.55		Ω
		I <sub>O</sub> =±800mA, V <sub>DD</sub> =6.5V, T <sub>A</sub> =25°C		0.6		Ω
<b>Protection Function Parameters</b>						
Protection Temperature	TSD			150		°C
TSD Hysteresis	TSDH			20		°C
<b>Power MOSFET Body Diode Conduction Characteristics</b>						
PMOS Body Diode	V <sub>PD</sub>	I=400mA, V <sub>CC</sub> =3V, V <sub>DD</sub> =I <sub>NA</sub> =I <sub>NB</sub> =0V		0.79		V
NMOS Body Diode	V <sub>ND</sub>	I=-400mA, V <sub>CC</sub> =V <sub>DD</sub> =3V, I <sub>NA</sub> =I <sub>NB</sub> =0V		0.77		V
<b>Motor Drive Time Parameters</b>						
Output Rise Time	t <sub>r</sub>	V <sub>CC</sub> =5V, V <sub>DD</sub> =5V, I <sub>NB</sub> =H, I <sub>NA</sub> input pulse signal; The signal duty ratio is 50% and the signal frequency is 20KHz; Load motor internal resistance is 1.3 Ω, motor idling.		70		ns
Output Fall Time	t <sub>f</sub>			25		ns
Output Delay Time	t <sub>rf</sub>			38		ns
Output Delay Time	t <sub>fr</sub>			85		ns

■ TYPICAL WAVEFORM

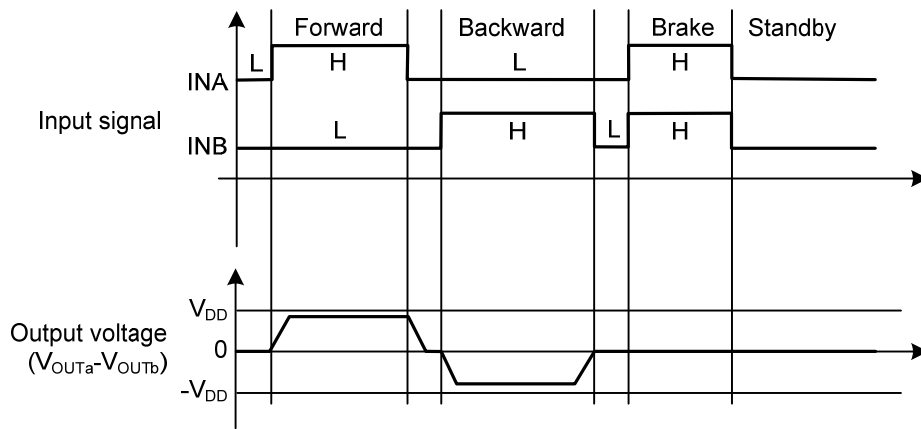

■ APPLICATION INFORMATION

1. Baseline Mode

a) Standby mode

In standby mode,  $INA=INB=L$ . All internal circuits, including the drive power tube, are off state. Circuit consumption is extremely low. In this mode, OUTA and OUTB both are in high-impedance state.

b) Forward mode

The forward mode is defined as:  $INA=H, INB=L$ , at this point the motor drive end OUTA outputs high level, and the motor drive end OUTB outputs low level, then the motor drives the current into the motor from the OUTA, and out from the OUTB to the ground. This motor rotation mode is defined as the forward mode.

c) Backward mode

The backward mode is defined as:  $INA=L, INB=H$ , at this point the motor drive end OUTB outputs high level, and the motor drive end OUTA outputs low level, then the motor drives the current into the motor from the OUTB, and out from the OUTA to the ground. This motor rotation mode is defined as the backward mode.

d) Brake mode

The brake mode is defined as:  $INA=H, INB=H$ , at this point motor drive ends OUTA and OUTB both output low level, and the energy stored in the motor will be quickly released through the OUTA end's NMOS tube or the OUTB end's NMOS tube, so the motor will stop turning in a short time.

Note: in brake mode, circuit will consume static power.

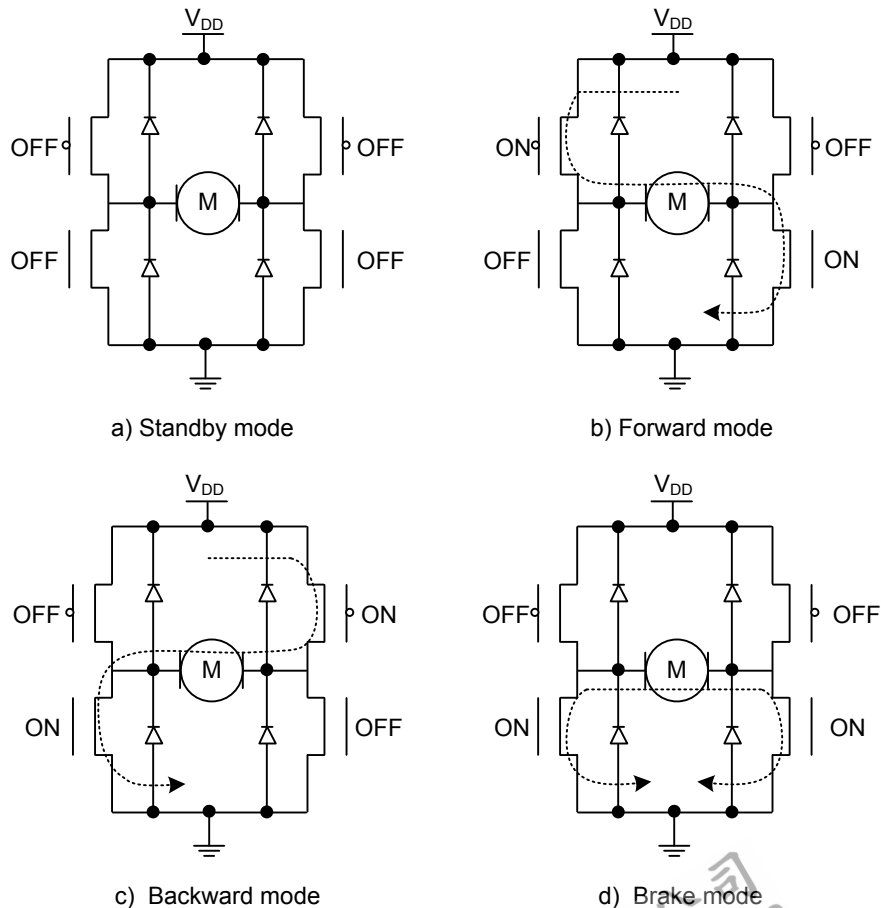

■ TYPICAL APPLICATION CIRCUIT

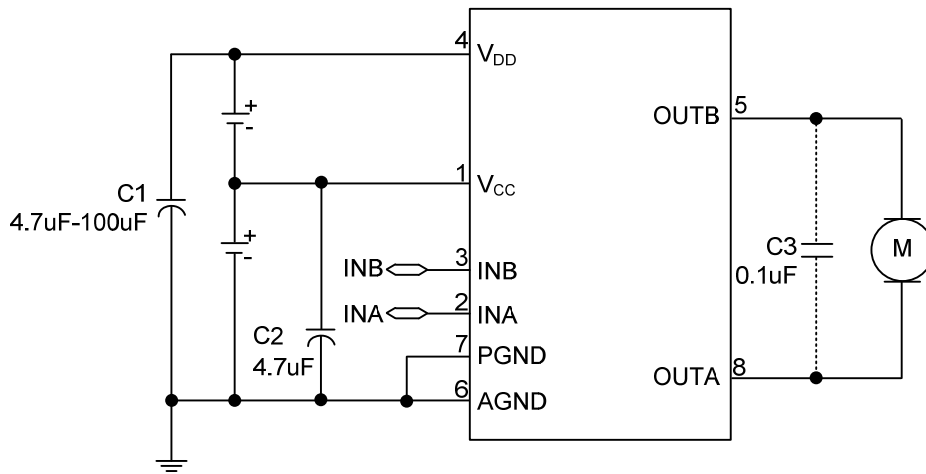

UTC assumes no responsibility for equipment failures that result from using products at values that exceed, even momentarily, rated values (such as maximum ratings, operating condition ranges, or other parameters) listed in products specifications of any and all UTC products described or contained herein. UTC products are not designed for use in life support appliances, devices or systems where malfunction of these products can be reasonably expected to result in personal injury. Reproduction in whole or in part is prohibited without the prior written consent of the copyright owner. UTC reserves the right to make changes to information published in this document, including without limitation specifications and product descriptions, at any time and without notice. This document supersedes and replaces all information supplied prior to the publication hereof.