



UPG70N60E

Preliminary

Insulated Gate Bipolar Transistor

600V, SMPS N-CHANNEL IGBT

DESCRIPTION

The UTC **UPG70N60E** is a N-channel IGBT. it uses UTC's advanced technology to provide customers with high input impedance, high switching speed and low conduction loss, etc.

The UTC **UPG70N60E** is suitable for high voltage switching, high frequency switch mode power supplies.

FEATURES

- * $V_{CE(SAT)} \leq 2.2V @ I_C=70A, V_{GE}=15V$
- * High switching speed
- * High input impedance
- * Low conduction loss

SYMBOL

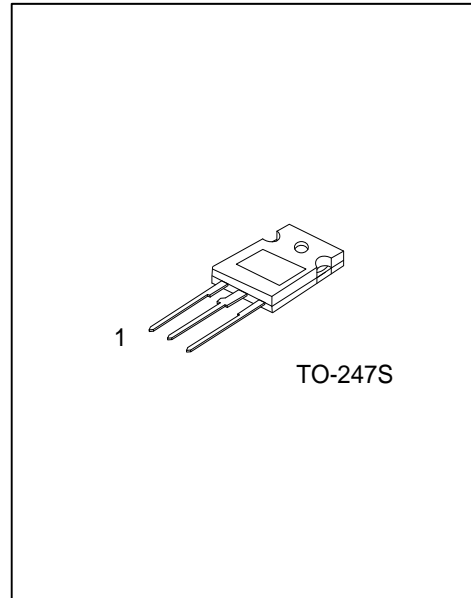
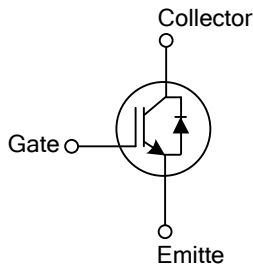

ORDERING INFORMATION

Ordering Number		Package	Pin Assignment			Packing
Lead Free	Halogen Free		1	2	3	
UPG70N60EL-T47S-T	UPG70N60EG-T47S-T	TO-247S	G	C	E	Tube

Note: Pin Assignment: G: Gate C: Collector E: Emitter

UPG70N60EG-T47S-T	(1)Packing Type	(1) T: Tube
	(2)Package Type	(2) T47S: TO-247S
	(3)Green Package	(3) G: Halogen Free and Lead Free, L: Lead Free

MARKING

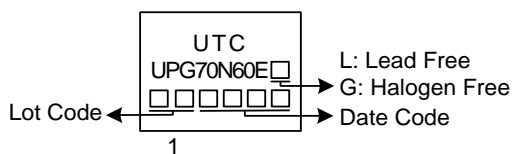

■ ABSOLUTE MAXIMUM RATINGS (T_C=25°C, unless otherwise specified)

PARAMETER	SYMBOL	RATINGS	UNIT
Collector-Emitter Voltage	V _{CES}	600	V
Gate to Emitter Voltage Continuous	V _{GES}	±20	V
Continuous Collector Current	T _C =25°C	140	A
	T _C =100°C	70	A
Collector Current Pulsed (Note 2)	I _{CM}	230	A
Continuous Forward Current	T _C =25°C	70	A
	T _C =100°C	35	A
Forward Current Pulsed	I _{FM}	136	A
Peak Diode Recovery dv/dt (Note 3)	dv/dt	6.9	V/ns
Power Dissipation	P _D	300	W
Junction Temperature	T _J	-55 ~ +150	°C
Storage Temperature Range	T _{STG}	-55 ~ +150	°C

- Notes: 1. Absolute maximum ratings are those values beyond which the device could be permanently damaged. Absolute maximum ratings are stress ratings only and functional device operation is not implied.
 2. Repetitive Rating: Pulse width limited by maximum junction temperature.
 3. I_F ≤ 30A, di/dt ≤ 200A/μs, V_{CC} ≤ BV_{CES}, Starting T_J=25°C

■ THERMAL DATA

PARAMETER	SYMBOL	RATINGS	UNIT
Junction to Case	θ _{JC}	0.417	°C/W

■ ELECTRICAL CHARACTERISTICS (T_J=25°C, unless otherwise specified)

PARAMETER	SYMBOL	TEST CONDITIONS	MIN	TYP	MAX	UNIT
OFF CHARACTERISTICS						
Collector-Emitter Breakdown Voltage	BV _{CES}	I _C =250μA, V _{GE} =0V	600			V
Collector-Emitter Leakage Current	I _{CES}	V _{CE} =600V, V _{GE} =0V			10	μA
Gate to Emitter Leakage Current	I _{GES}	V _{CE} =0V, V _{GE} =±20V			±400	nA
ON CHARACTERISTICS						
Collector-Emitter Saturation Voltage	V _{CE(SAT)}	I _C =70A, V _{GE} =15V	T _J =25°C	1.75	2.2	V
			T _J =150°C	1.95		V
Gate to Emitter Threshold Voltage	V _{GE(TH)}	I _C =250μA, V _{CE} =V _{GE}	4.0		6.5	V
DYNAMIC CHARACTERISTICS						
Input Capacitance	C _{IES}	V _{CE} =30V, V _{GE} =0V, f=1MHz		2940		pF
Output Capacitance	C _{OES}			290		pF
Reverse Transfer Capacitance	C _{RES}			53		pF
SWITCHING CHARACTERISTICS						
Total Gate Charge	Q _G	I _C =70A, V _{CE} =100V, V _{GE} =10V		97		nC
Gate-Emitter Charge	Q _{GE}			18		nC
Gate-Collector Charge	Q _{GC}			45		nC
Current Turn-On Delay Time	t _{D(ON)}	I _C =70A, V _{CE} =50V, V _{GE} =15V, R _G =10Ω		82		ns
Current Rise Time	t _R			98		ns
Current Turn-Off Delay Time	t _{D(OFF)}			165		ns
Current Fall Time	t _F			265		ns
DRAIN-SOURCE DIODE CHARACTERISTICS						
Forward Voltage Drop	V _{FM}	I _F =12A			2.7	V
Reverse Recovery Time	t _{rr}	I _F =12A, di/dt=100A/μs, V _{CC} =400V		100		ns
Reverse Recovery Charge	Q _{rr}			312		nC

Note: Pulse Test: Pulse width ≤ 50μs.

■ TEST CIRCUIT AND WAVEFORMS

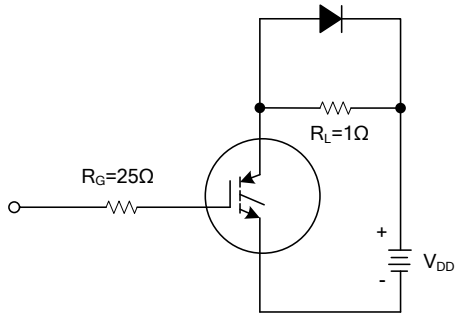

Fig 1. INDUCTIVE SWITCHING TEST CIRCUIT

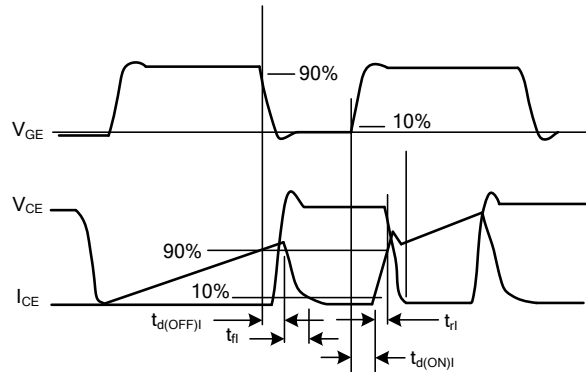

Fig 2. SWITCHING TEST WAVEFORMS

UTC assumes no responsibility for equipment failures that result from using products at values that exceed, even momentarily, rated values (such as maximum ratings, operating condition ranges, or other parameters) listed in products specifications of any and all UTC products described or contained herein. UTC products are not designed for use in life support appliances, devices or systems where malfunction of these products can be reasonably expected to result in personal injury. Reproduction in whole or in part is prohibited without the prior written consent of the copyright owner. UTC reserves the right to make changes to information published in this document, including without limitation specifications and product descriptions, at any time and without notice. This document supersedes and replaces all information supplied prior to the publication hereof.