



UR5596

CMOS IC

DDR TERMINATION REGULATOR

DESCRIPTION

The UTC **UR5596** is a linear bus termination regulator and designed to meet JEDEC SSTL-2(Stub-Series Terminated Logic) specifications for termination of DDR-SDRAM. It also can be used in SSTL-3 or HSTL (High-Speed Transceiver Logic) scheme. The device contains a high-speed OP AMP to provide excellent response to the load transients, and can deliver 1.5A continuous current and transient peaks up to 3A in the application as required for DDR-SDRAM termination.

The UTC **UR5596** also incorporates a V_{SENSE} pin to provide superior load regulation and a V_{REF} output as a reference for the chipset and DIMMs. Besides, an active low shutdown (**SHDN**) pin provides Suspend To RAM (STR) functionality. When **SHDN** is pulled low the V_{TT} output will tri-state providing a high impedance output, but, V_{REF} will remain active. A power savings advantage can be obtained in this mode through lower quiescent current.

Regarding the output, V_{TT} is capable of sinking and sourcing current while regulating the output voltage equal to $V_{DDQ}/2$. The output stage has been designed to maintain excellent load regulation while preventing shoot through. The UTC **UR5596** also incorporates two distinct power rails that separates the analog circuitry from the power output stage. This allows a split rail approach to be utilized to decrease internal power dissipation and permits UTC **UR5596** to provide a termination solution for DDRII SDRAM.

FEATURES

- * Source and sink current
- * Low output voltage offset
- * No external resistors required
- * Linear topology
- * Suspend To Ram (STR) functionality
- * Low external component count
- * Thermal shutdown protection

ORDERING INFORMATION

Ordering Number	Package	Packing
UR5596G-S08-R	SOP-8	Tape Reel
UR5596G-SH2-R	HSOP-8	Tape Reel

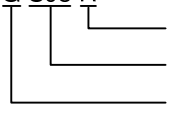
<p>UR5596G-S08-R</p>  <ul style="list-style-type: none"> (1) Packing Type (2) Package Type (3) Green Package 	<ul style="list-style-type: none"> (1) R: Tape Reel (2) S08: SOP-8 (3) G: Halogen Free and Lead Free
--	---

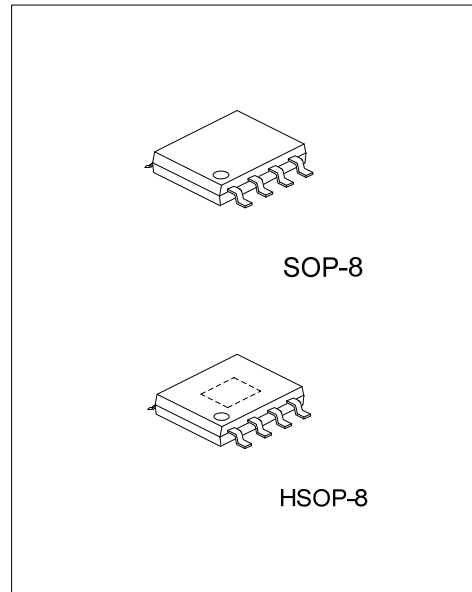

MARKING

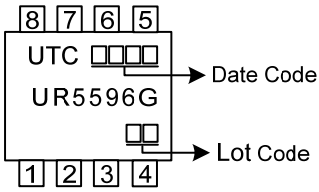

PIN CONFIGURATION

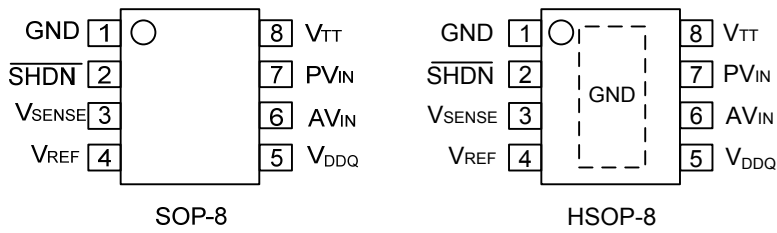

PIN DESCRIPTION

PIN NO.	PIN NAME	PIN FUNCTION
1	GND	Ground
2	SHDN	Shutdown
3	V _{SENSE}	Feedback pin for regulating V _{TT} .
4	V _{REF}	Buffered internal reference voltage of V _{DDQ} /2
5	V _{DDQ}	Input for internal reference equal to V _{DDQ} /2
6	A _{VIN}	Analog input pin
7	P _{VIN}	Power input pin
8	V _{TT}	Output voltage for connection to termination resistors

BLOCK DIAGRAM

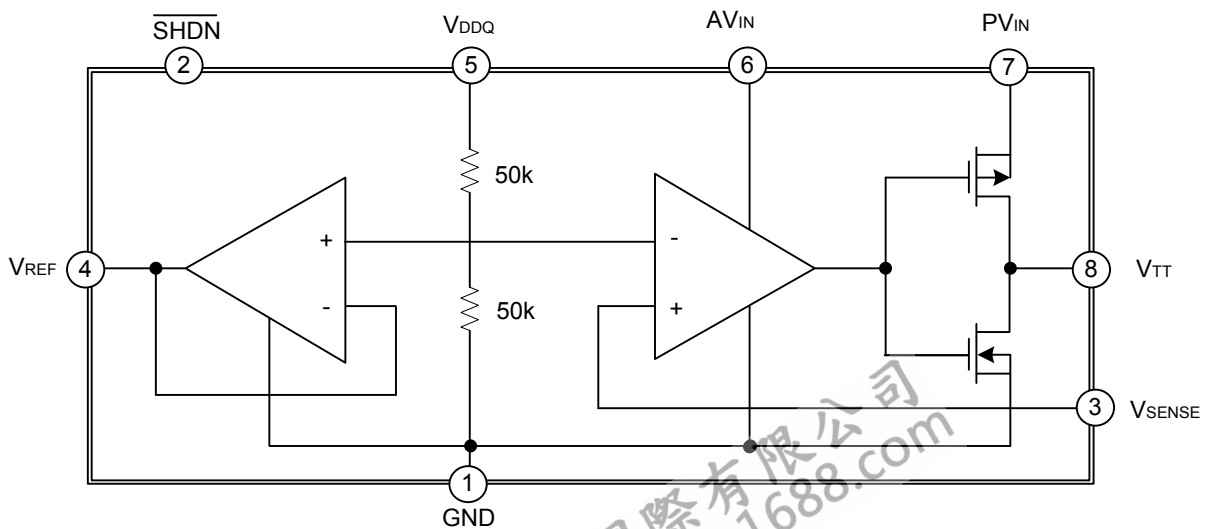

■ ABSOLUTE MAXIMUM RATINGS

PARAMETER	SYMBOL	RATINGS	UNIT	
Supply Voltage	PV _{IN} , AV _{IN} , V _{DDQ} to GND	V _{DD}	-0.3 ~ +6	V
	AV _{IN} to GND(Note 1)	V _{DD}	2.2 ~ 5.5	V
Junction Temperature	T _J	+150	°C	
Operation Temperature	T _{OPR}	-40 ~ +85	°C	
Storage Temperature	T _{STG}	-40 ~ +150	°C	

Note: Absolute maximum ratings are those values beyond which the device could be permanently damaged. Absolute maximum ratings are stress ratings only and functional device operation is not implied.

■ THERMAL DATA

PARAMETER	SYMBOL	RATINGS	UNIT
Thermal Resistance Junction-Ambient	θ_{JA}	150	°C/W

■ ELECTRICAL CHARACTERISTICS

(T_J=25°C, V_{IN}=AV_{IN}=PV_{IN}=2.5V, V_{DDQ}=2.5V, unless otherwise specified).

PARAMETER	SYMBOL	TEST CONDITIONS	MIN	TYP	MAX	UNIT
V _{REF} Voltage	V _{REF}	V _{IN} = V _{DDQ} = 2.3V	1.130	1.158	1.185	V
		V _{IN} = V _{DDQ} = 2.5V	1.235	1.258	1.285	
		V _{IN} = V _{DDQ} = 2.7V	1.335	1.358	1.385	
V _{TT} Output Voltage	I _{OUT} = 0A	V _{IN} = V _{DDQ} = 2.3V	1.125	1.159	1.190	V
		V _{IN} = V _{DDQ} = 2.5V	1.225	1.259	1.290	
		V _{IN} = V _{DDQ} = 2.7V	1.325	1.359	1.390	
	I _{OUT} = ±1.5A	V _{IN} = V _{DDQ} = 2.3V	1.125	1.159	1.190	
		V _{IN} = V _{DDQ} = 2.5V	1.225	1.259	1.290	
		V _{IN} = V _{DDQ} = 2.7V	1.325	1.359	1.390	
Minimum Shutdown Level	High	V _{IH}	1.9			V
	Low	V _{IL}			0.8	
V _{TT} Output Voltage Offset (V _{REF} - V _{TT})	$\frac{V_{OS_{TT}}}{V_{TT}}$	I _{OUT} = 0A	-20	0	20	mV
		I _{OUT} = -1.5A	-25	0	25	
		I _{OUT} = +1.5A	-25	0	25	
Quiescent Current	I _Q	I _{OUT} = 0A		320	500	μA
Quiescent Current in Shutdown	I _{SD}	SD = 0V		115	150	μA
Shutdown Leakage Current	I _{Q SD}	SD = 0V		2	5	μA
V _{TT} Leakage Current in Shutdown	I _V	SD = 0V V _{TT} = 1.25V		1	10	μA
V _{SENSE} Input Current	I _{SENSE}			13		nA
V _{REF} Output Impedance	Z _{VREF}	I _{REF} = -30 ~ +30 μA		2.5		kΩ
V _{DDQ} Input Impedance	Z _{VDDQ}			100		kΩ
Thermal Shutdown	T _{SD}			165		°C
Thermal Shutdown Hysteresis	T _{SD-HYS}			10		°C

■ PIN DESCRIPTIONS

AV_{IN} , PV_{IN}

Input supply pins. AV_{IN} is used to supply all the internal analog circuits and PV_{IN} is used to provide the output stage to create V_{TT}. These pins have the capability to work off separate supplies depending on the application. Higher voltages on PV_{IN} will increase the maximum continuous output current because of output RDSON limitations at voltages close to V_{TT}. But the internal power loss will also increase, thermally limiting the design. If the junction temperature exceeds the thermal shutdown then the part will enter a shutdown state identical to the manual shutdown where V_{TT} is tri-stated and V_{REF} remains active.

For SSTL-2 applications, a good compromise would be to connect the AV_{IN} and PV_{IN} directly together at 2.5V. This eliminates the need for bypassing the two supply pins separately. The only limitation on input voltage selection is that PV_{IN} must be equal to or lower than AV_{IN}. It is recommended to connect PV_{IN} to voltage rails equal to or less than 3.3V to prevent the thermal limit from tripping because of excessive internal power dissipation.

V_{DDQ}

The input pin used to create the internal reference voltage from a resistor divider of two internal 50kΩ resistors for regulating V_{TT} and to guarantee V_{TT} will track V_{DDQ}/2 precisely. As a remote sense by connecting V_{DDQ} directly to the 2.5V rail for SSTL-2 applications is an optimal implementation of V_{DDQ} at the DIMM. This ensures that the reference voltage tracks the DDR memory rails precisely without a large voltage drop from the power lines.

V_{SENSE}

The sense pin supply improved remote load regulation, if remote load regulation is not used then the V_{SENSE} pin must still be connected to V_{TT}. A long trace will cause a significant IR drop resulting in a termination voltage lower at one end of the bus than the other. Connect V_{SENSE} pin to the middle of the bus to provide a better distribution across the entire termination bus then DDR performance will be improved. Take notice of when a long V_{SENSE} trace is implemented in close proximity to the memory, noise pickup in the V_{SENSE} trace can cause problems with precise regulation of V_{TT}. A ceramic capacitor of 0.1μF is placed to next the V_{SENSE} pin can help filter any high frequency signals and preventing errors.

V_{REF}

V_{REF} supply the buffered output of the internal reference voltage V_{DDQ}/2. This output delivers the reference voltage for the Northbridge chipset and memory. Since these inputs are typically extremely high impedance, there should be little current drawn from V_{REF}. A 0.1μF~0.01μF ceramic capacitor could be used to acquire better performance, located close to the pin to help with noise. This output remains active during the shutdown state and thermal shutdown events for the suspend to RAM functionality.

V_{TT}

V_{TT} is a regulated output for the bus resistors termination of DDR-SDRAM. It can track precisely the V_{DDQ}/2 voltage with the sinking and sourcing current capability. The UTC **UR5596** is designed to handle peak transient currents of up to ± 3A with a fast transient response. If a transient is expected to remain above the maximum continuous current rating for a significant amount of time then the output capacitor size should be large enough to prevent an excessive voltage drop.

Although UTC **UR5596** can handle large transient output currents, but it can not handling these for long durations since the limited thermal dissipation capability of SOP-8 package. If large currents are required for longer durations, then must ensure the maximum junction temperature is not exceeded, otherwise, the maximum output current will be degraded with heating. Proper thermal de-rating should always be used. While the temperature beyond the junction temperature, the thermal shutdown protection will be functioned, then V_{TT} will tri-state until the part returns below the hysteretic trigger point.

■ CAPACITOR SELECTION

A capacitor is recommended for improve performance during large load transients to prevent the input rail from dropping, even though **UR5596** does not require for input stability. The input capacitor should be located as close as possible to the PV_{IN} pin. The typical recommended value for AL electrolytic capacitors is 50 μF and 10 μF with X5R or better for Ceramic capacitors. If AV_{IN} and PV_{IN} are separated, the 47μF capacitor should be placed as close to possible to the PV_{IN} rail. An additional 0.1uF ceramic capacitor can be placed on the AVIN rail to prevent excessive noise from coupling into the device.

UTC **UR5596** has been designed to be insensitive of output capacitor size or ESR (Equivalent Series Resistance). The choice for output capacitor depends on the application and the requirements for load transient response of V_{TT}. As a general recommendation the output capacitor should be sized above 100 μF with a low ESR for SSTL applications with DDR-SDRAM. The value of ESR should be determined by the maximum current spikes expected and the extent at which the output voltage is allowed to droop.

■ THERMAL DISSIPATION

The UR5596 will generate heat result from internal power dissipation when current flow working. The device might be damaged any beyond maximum junction temperature rating. The maximum allowable internal temperature rise (T_{Rmax}) can be calculated given the maximum ambient temperature (T_{Amax}) of the application and the maximum allowable junction temperature (T_{Jmax}).

$$T_{Rmax} = T_{Jmax} - T_{Amax}$$

From this equation, the maximum power dissipation (P_{Dmax}) of the part can be calculated:

$$P_{Dmax} = T_{Rmax} / \theta_{JA}$$

The θ_{JA} of UR5596 can be calculated (refer to JEDEC standard) and will depend on several package type, materials, ambient air temperature and so on.

■ TYPICAL APPLICATION CIRCUITS

Following demonstrate several different application circuits to illustrate some of the options that are possible in configuring the UTC **UR5596**. The individual circuit performance can be found in the Typical Performance Characteristics that curve graphs illustrate how the maximum output current is affected by changes in AV_{IN} and PV_{IN} .

STUB-SERIES TERMINATED LOGIC(SSTL) TERMINATION SCHEME

SSTL was created to improve signal integrity of the data transmission across the memory bus. This termination scheme is essential to prevent data error from signal reflections while transmitting at high frequencies encountered with DDR-SDRAM. Class II single parallel termination(SSTL-2) is the most popular termination form. It involves one R_S series resistor from the chipset to the memory and one R_T termination resistor (refer to Figure 1). R_S and R_T are changeable to meet the current requirement from UR5596, the recommended values both R_S and R_T are 25Ω .

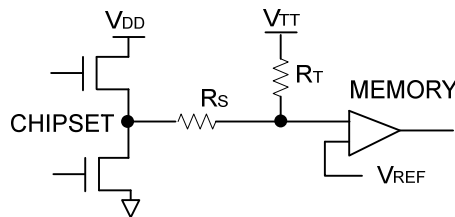

Figure 1. SSTL-Termination Scheme

FOR SSTL-2 APPLICATIONS

For the majority of applications that implement the SSTL- 2 termination scheme, it is recommended to connect all the input rails to the 2.5V rail as Figure 2. This provides an optimal trade-off between power dissipation and component count and selection.

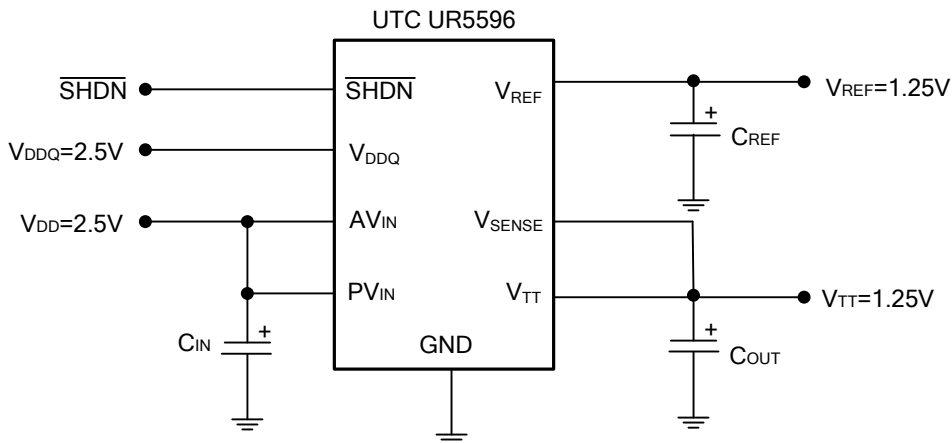

Figure 2. Recommended SSTL-2 Implementation

■ TYPICAL APPLICATION CIRCUITS(Cont.)

Figure 3 illustrate another application that the power rails are split when power dissipation or efficiency are concerned. The output stage (PV_{IN}) can be as lower as 1.8V, and the analog circuitry (AV_{IN}) can be connected to a higher rail such as 2.5V, 3.3V or 5V. This allows the internal power dissipation to be lowered when sourcing current from V_{TT} , but the disadvantage of this circuit is the maximum continuous current is reduced.

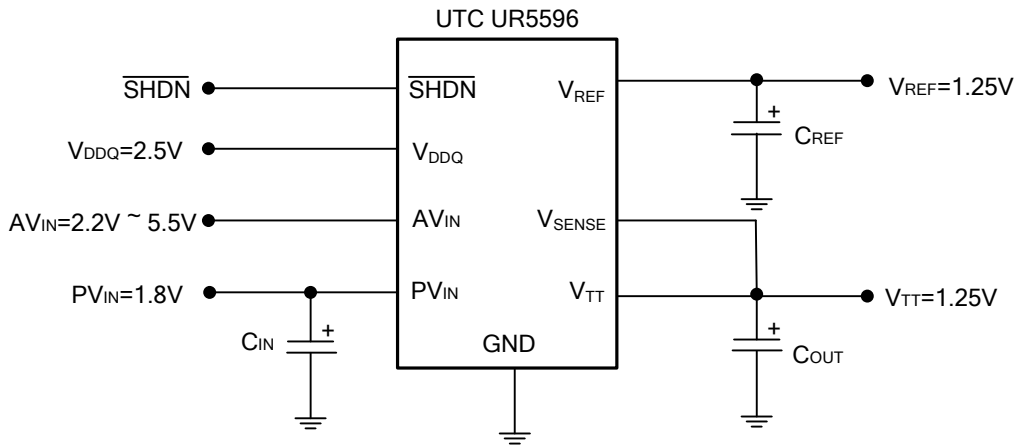

Figure 3. Lower Power Dissipation SSTL-2 Implementation

The third optional application is that PV_{IN} connect to 3.3V and AV_{IN} will be always limited to operation on the 3.3V or 5V to always equal or higher than PV_{IN} . This configuration has the ability to provide the maximum continuous output current at the downside of higher thermal dissipation. The power dissipation increasing problem must be careful to prevent the junction temperature to exceed the maximum rating. Because of this risk it is not recommended to supply the output stage with a voltage higher than a nominal 3.3V rail.

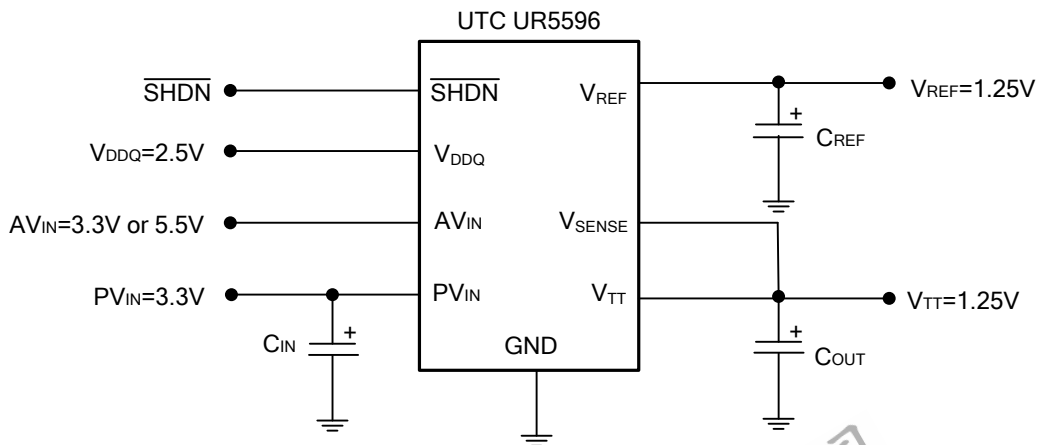

Figure 4. SSTL-2 Implementation with higher voltage rails

■ TYPICAL APPLICATION CIRCUITS(Cont.)

FOR DDR-II APPLICATIONS

As a result of the separate V_{DDQ} pin and an internal resistor divider, **UR5596** can be utilized in DDR-II system, figure 5 and 6 show two recommended circuits in DDR-II SDRAM application. The output stage is connected to the 1.8V rail and the AV_{IN} pin can be connected to either a 3.3V or 5V rail. If it is not desirable to use the 1.8V rail it is possible to connect the output stage to a 3.3V rail. The power dissipation increasing concern must be careful as well SSTL-II application. The advantage of configuration of figure 6 is that it has the ability to source and sink a higher maximum continuous current.

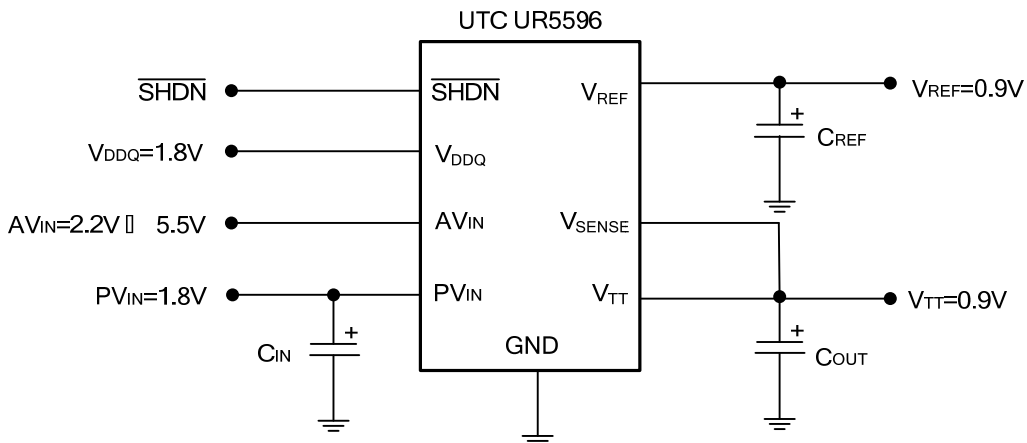

Figure 5. Recommended DDR-II Termination

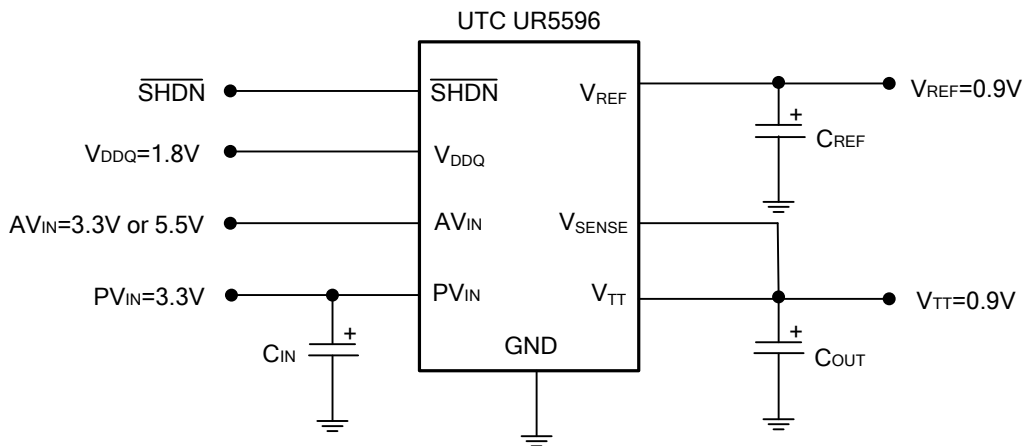
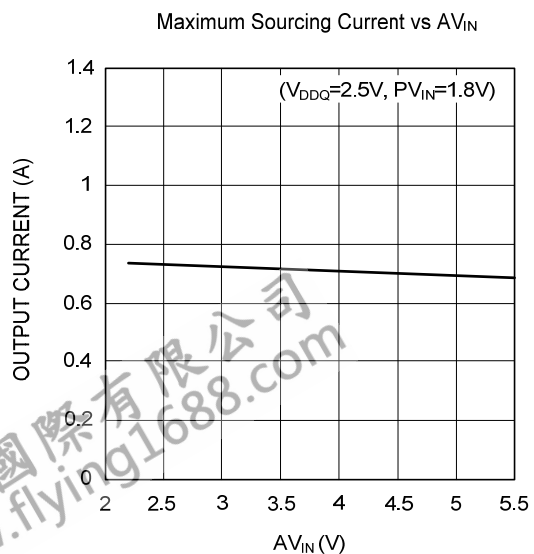
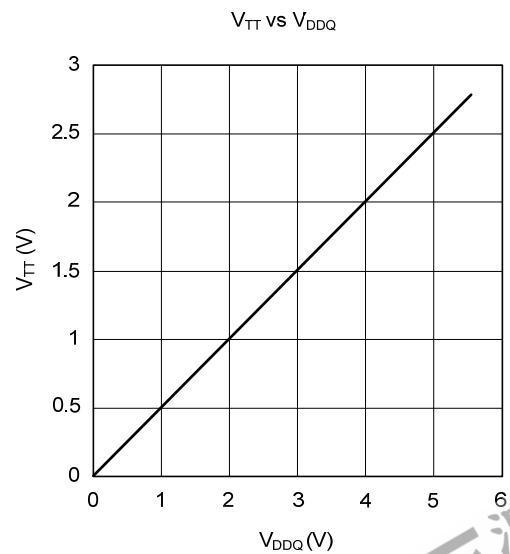
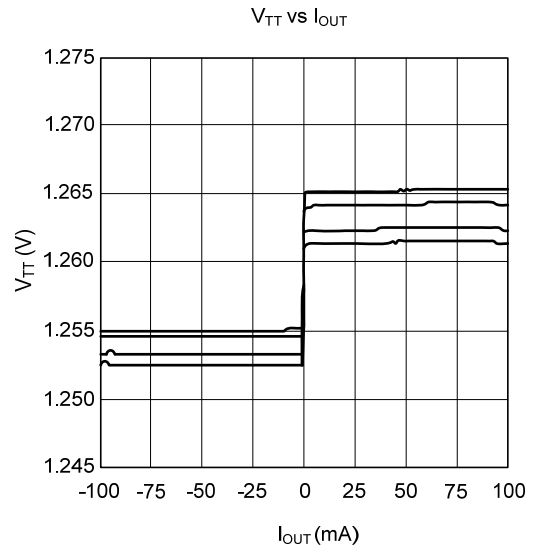
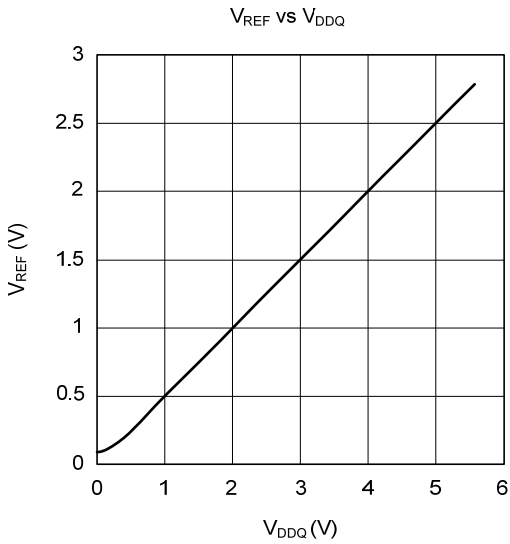
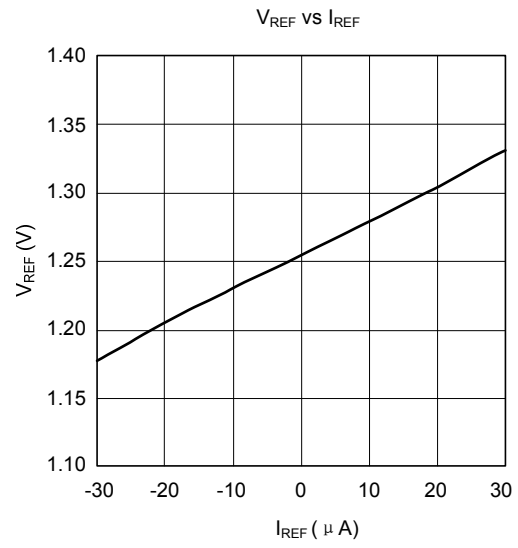
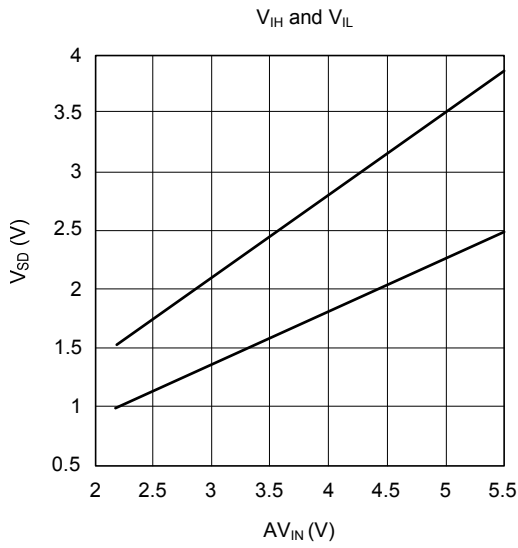

Figure 6. DDR-II Termination with higher voltage rails

■ TYPICAL CHARACTERISTICS



■ TYPICAL CHARACTERISTICS(cont.)

Maximum Sourcing Current vs AV_{IN}

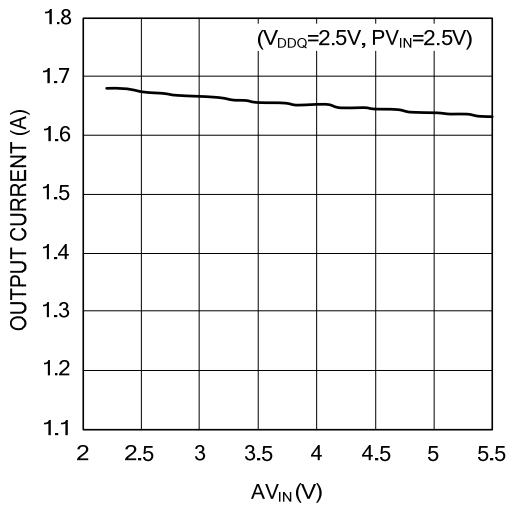

Maximum Sourcing Current vs AV_{IN}

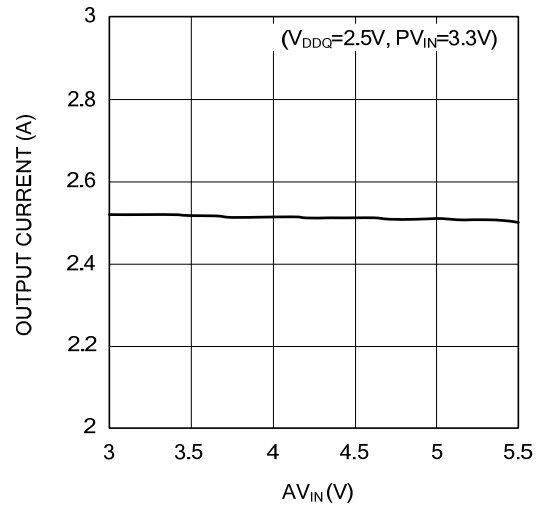

Maximum Sinking Current vs AV_{IN}
($V_{DDQ}=2.5V$)

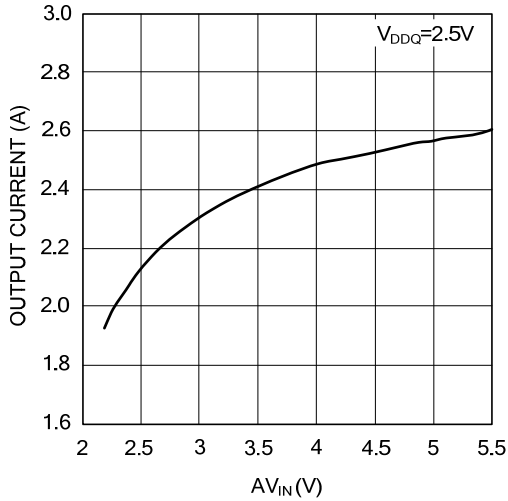

Maximum Sourcing Current vs AV_{IN}

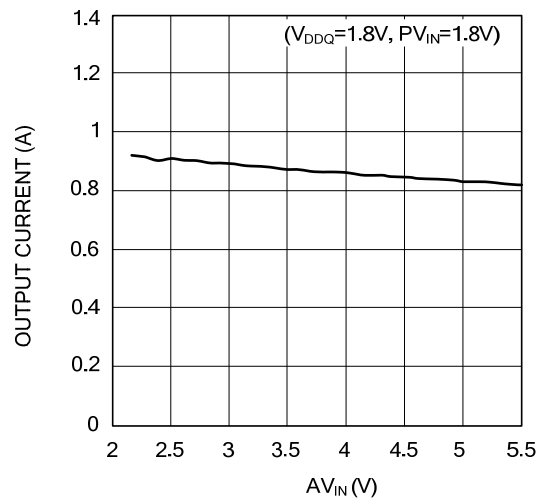

Maximum Sinking Current vs AV_{IN}
($V_{DDQ}=1.8V$)

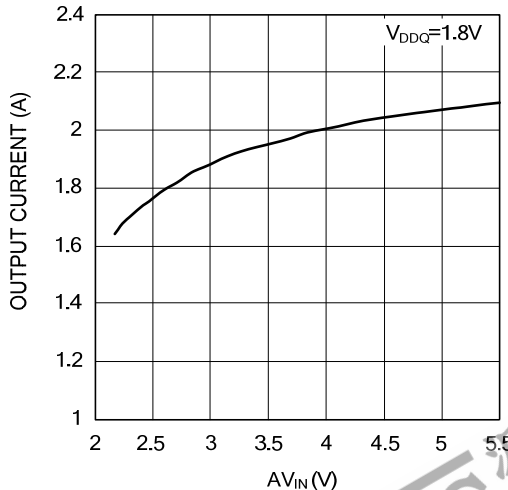

Maximum Sourcing Current vs AV_{IN}
($V_{DDQ}=1.8V, PV_{IN}=3.3V$)

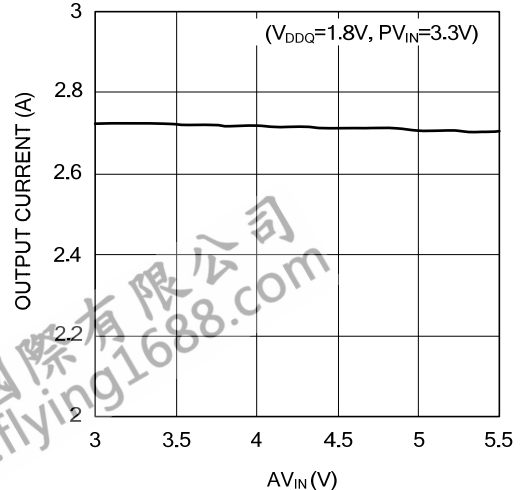

UTC assumes no responsibility for equipment failures that result from using products at values that exceed, even momentarily, rated values (such as maximum ratings, operating condition ranges, or other parameters) listed in products specifications of any and all UTC products described or contained herein. UTC products are not designed for use in life support appliances, devices or systems where malfunction of these products can be reasonably expected to result in personal injury. Reproduction in whole or in part is prohibited without the prior written consent of the copyright owner. The information presented in this document does not form part of any quotation or contract, is believed to be accurate and reliable and may be changed without notice.