



### USB HIGH-SIDE POWER SWITCH ADVANCE INFORMATION

#### DESCRIPTION

The UTC **US1528** is an integrated high-side power switch. It is designed particularly for self-powered and bus-powered USB (Universal serial bus) applications.

The UTC **US1528** meets the requirements of the USB. The low on-resistance of the switch meets USB voltage drop requirements. When the output load becomes higher than the current-limit threshold, the UTC **US1528** switches into constant-current mode and limits the output current at 1.4A (TYP).

An open-drain flag, playing a role as the MOSFET output, is included to indicate error conditions to the local USB controller. A thermal shutdown circuit protects this device from catastrophic switch failure, which is caused by increasing power dissipation when continuous heavy loads or short circuit occurs. In addition, soft start is used to avoid the momentary voltage drop generated on the upstream port that may occur when the switch is enabled in bus-powered applications. A UVLO (under-voltage lockout) circuit is used to keep the device off unless there is a valid input voltage present, and an enable input that is compatible with both 3.3V and 5V logic.

The UTC **US1528** can be used for high-side power protection switch, USB power management, USB host and self-powered hubs, hot plug-in power supplies and battery-charger circuits.

#### FEATURES

- \* Open-Drain Fault Flag
- \* Low on-Resistance MOSFET: Typical 110mΩ(at 5.0V)
- \* Operating Voltage Varying From 3.0V to 5.5V
- \* Output can be Forced Higher than Input when Operating in Off State.
- \* Slow Turn-On (Soft-Start) and Fast Turn-Off
- \* On-State Supply Current: 100 μA (TYP)
- \* Standby Supply Current: 1μA (TYP)
- \* Current Limit: 1.4A (TYP)
- \* Thermal Shutdown Protection Circuit
- \* UVLO (Under-Voltage Lockout): 2.4V (TYP)
- \* Logic Level Enable Pin, Available with Active-High/Low Version

#### ORDERING INFORMATION

Ordering Number	Package	Packing
US1528XG-S08-R	SOP-8	Tape Reel

<p>US1528XG-S08-R</p>	<ul style="list-style-type: none"> <li>(1)Packing Type</li> <li>(2)Package Type</li> <li>(3)Halogen Free</li> <li>(4)Logic Level Enable Pin</li> </ul>	<ul style="list-style-type: none"> <li>(1) R: Tape Reel</li> <li>(2) S08: SOP-8</li> <li>(3) G: Halogen Free</li> <li>(4) L: Active Low H: Active High</li> </ul>
-----------------------	--	---

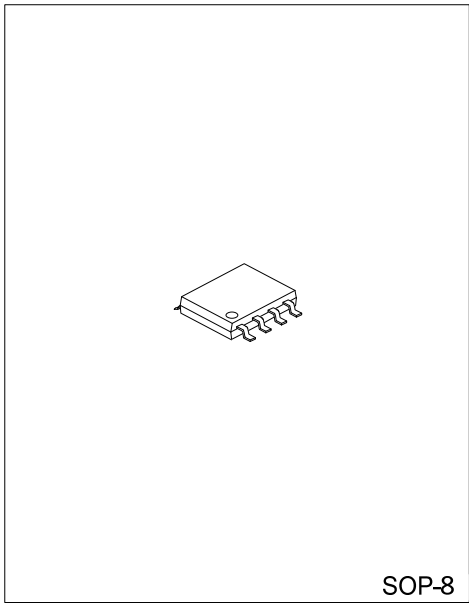

■ PIN CONFIGURATION

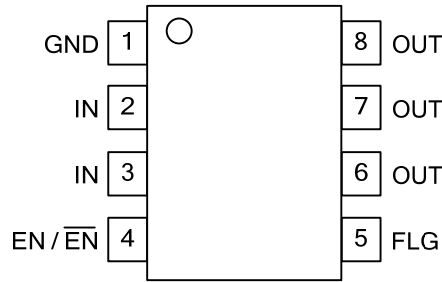

■ PIN DESCRIPTION

PIN NO.	PIN NAME	DESCRIPTION
1	GND	Ground.
2, 3	IN	Input Supply: Output MOSFET source, which also supplies IC's internal circuitry. Connect to positive supply.
4	EN	Active-High switch enable input. A logic low turns on the switch.
	$\overline{\text{EN}}$	Active-Low switch enable input. A logic low turns on the switch.
5	FLG	Open-Drain Fault Flag (Output): Active-low, open-drain output. Indicates overcurrent, thermal shutdown and UVLO.
6, 7, 8	OUT	Switch Output: Output MOSFET drain. Typically connect to switched side of load.

FLYING 汎翔國際有限公司  
[www.flying1688.com](http://www.flying1688.com)

■ BLOCK DIAGRAM

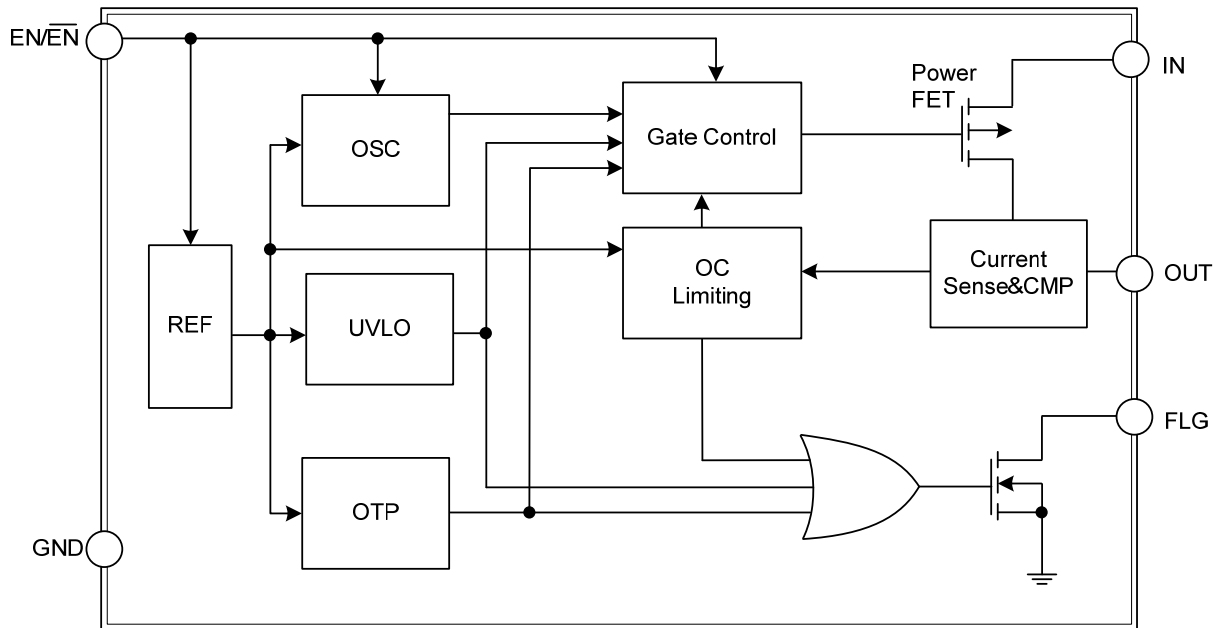

FLYING 沉翊國際有限公司  
www.flying1688.com

### ■ ABSOLUTE MAXIMUM RATING

PARAMETER	SYMBOL	RATINGS	UNIT
Supply Voltage	$V_{IN}$	+6.0	V
Fault Flag Voltage	$V_{FLG}$	+6.0	V
Fault Flag Current	$I_{FLG}$	50	mA
Output Voltage	$V_{OUT}$	+6.0	V
Output Current	$I_{OUT}$	Internally Limited	
Enable Input	$V_{EN}$	-0.3~6	V
Storage Temperature	$T_{STG}$	-65~+150	°C

Notes: Absolute maximum ratings are those values beyond which the device could be permanently damaged.  
Absolute maximum ratings are stress ratings only and functional device operation is not implied.

### ■ OPERATING RATINGS

PARAMETER	SYMBOL	RATINGS	UNIT
Supply Voltage	$V_{IN}$	+3~+5.5	V
Ambient Operating Temperature	$T_{OPR}$	-40~85	°C

### ■ THERMAL DATA

PARAMETER	SYMBOL	RATINGS	UNIT
Junction to Ambient	$\theta_{JA}$	160	°C/W

### ■ ELECTRICAL CHARACTERISTICS ( $V_{IN}=+5V$ , $T_A=25^\circ C$ )

PARAMETER	SYMBOL	TEST CONDITIONS	MIN	TYP	MAX	UNIT
IN Supply Current (Note)	$I_{S(OFF)}$	switch off, OUT = open		1	5	$\mu A$
	$I_{S(ON)}$	switch on, OUT = open		100	160	$\mu A$
EN/ $\overline{EN}$ Enable Threshold	$V_{IH}$	low to high transition			2.5	V
	$V_{IL}$	high to low transition(Note)	0.8			V
EN/ $\overline{EN}$ Input Current	$I_{EN(H)}$	$V_{EN}=V_{OH(min)}=2.5V$		0.01	1	$\mu A$
	$I_{EN(L)}$	$V_{EN}=V_{OL(max)}=1.0V$		0.01	1	$\mu A$
EN/ $\overline{EN}$ Input Capacitance				1		pF
Switch Resistance	$R_{ON}$	$V_{IN}=5V, I_{OUT}=500mA$		110	140	m $\Omega$
		$V_{IN}=3.3V, I_{OUT}=500mA$		130	180	m $\Omega$
OUT Turn-On Delay	$t_{ON}$	$R_L=10\Omega$		0.03		ms
OUT Turn-On Rise Time	$t_R$	$R_L=10\Omega, C_L=100\mu F$		0.5		ms
OUT Turn-Off Delay	$t_{OFF}$	$R_L=10\Omega$		1	20	$\mu s$
OUT Turn-Off Fall Time	$t_F$	$R_L=10\Omega$		1	20	$\mu s$
OUT Leakage Current	$I_{O(LEAK)}$			1	10	$\mu A$
Short Circuit Current Limit	$I_{SHORT}$	Enable into load	1.0	1.4	2.0	A
Circuit Limit Threshold		Ramped load applied to enabled output	2.0	2.7	3.5	A
Overtemperature Shutdown Threshold	$OT_{Threshold}$	$T_J$ increasing		135		°C
		$T_J$ decreasing		125		°C
FLG Output Resistance	$R_{ON(FLAG)}$	$V_{IN}=5V, I_L=10mA$		10	25	$\Omega$
		$V_{IN}=3.3V, I_L=10mA$		15	40	$\Omega$
FLG Off Current	$I_{FLAG}$	$V_{FLAG}=5V$		0.01	1	$\mu A$
UVLO Threshold	$V_{UVLO}$	$V_{IN}$ =increasing		2.5		V
		$V_{IN}$ =decreasing		2.3		V

Note: For the UTC **US1528**, off is  $\geq 2.5V$  and on is  $\leq 0.8V$ . The enable input, EN has approximately 200mV of hysteresis.

## ■ FUNCTIONAL DESCRIPTION

The UTC **US1528** is high-side single channel power switch; it has an enable input in active low. Fault conditions turn off or inhibit turn-on of the output transistors.

### Input and Output

IN pin (input) is the power supply connection to the logic circuitry and the source of the output MOSFET. OUT pin (output) is the output MOSFET's drain. Current flows through the switch from IN pin to OUT pin toward the load in many applications. All OUT pins must be connected together to the load.

The output MOSFET and driving circuit are also designed to allow the MOSFET drain to be externally forced to a higher voltage than the source ( $V_{OUT} > V_{IN}$ ) when the switch is off. This avoids undesirable drain-to-body diode current flow by connecting the body to the most positive voltage. If  $V_{OUT} > V_{IN}$  when switch is enabled, current will flow from  $V_{OUT}$  to  $V_{IN}$ .

### Thermal Shutdown

Thermal shutdown is designed to prevent this device from being damaged due to excessive power dissipation. It is used to turn off the output MOSFET if the temperature is higher than 135°C, 10°C of hysteresis prevents the switch from turning on until the die temperature drops to 125°C. Thermal shutdown circuit functions only when the switch is enabled.

### Undervoltage Lockout

UVLO (Undervoltage Lockout) turns off the MOSFET switch once the input voltage falls below 2.3V (TYP) and if the input voltage exceeds 2.5V (TYP), the switch will be turned on. UVLO detection functions only when the switch is enabled.

### Current Sensing and Limiting

The current limit threshold is fixed internally, allowing a 0.5A minimum current to flow through the output MOSFET. However, the current limit threshold can prevent the output MOSFET and external load from being damage. A current sense circuit protects the MOSFET switch's output current. If output current becomes higher than the current limit threshold, the output MOSFET switch is turned off. The reaction to an overcurrent is measured with the following scenarios:

#### Switch Enabled into Heavy Load

If the switch is powered on or enabled into a heavy load or short-circuit, the switch enters a constant-current mode immediately, reducing the output voltage.

#### Heavy Load Applied to Enabled Switch

When a heavy load is applied, a large-undesired transient current occurs which may damage the switch. Then the current limit circuit may turn off the switch, folding back into constant-current mode.

### Fault Flag

Fault flag is an open-drained output of an N-channel MOSFET. It drops low to indicate error conditions as follows: current limiting, UVLO, or thermal shutdown. The flag output MOSFET is capable of sinking a 10mA load to typically 100mV above ground.

■ APPLICATIONS INFORMATION

**Supply Filtering**

In order to control supply transients, a bypass capacitor is located nearly between IN to GND. 0.1μF ~ 1μF is suitable (See Figure 1). Without a bypass capacitor, an output short may cause sufficient ringing on the input (from supply lead inductance) to damage internal control circuitry.

Input transients must not exceed the absolute maximum supply voltage ( $V_{IN Max} = 6V$ ) even for a short duration.

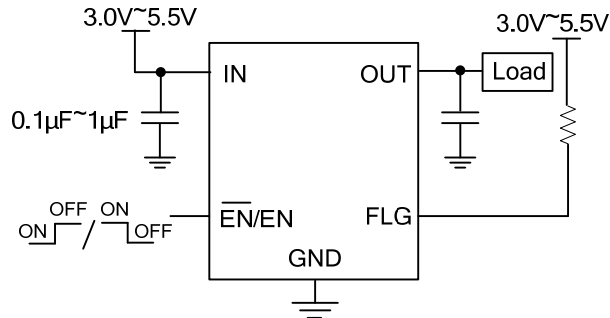

Figure 1. Supply Bypassing

**EN/EN-bar, The Active-High/Low Enable Input**

For a clearly defined input, the EN/EN-bar pin, with 0.2V hysteresis, must be driven logic high or logic low. Floating the input may cause unpredictable operation. EN/EN-bar should not be allowed to go negative with respect to GND.

**Soft Start**

The UTC **US1528** is high impedance when off and slowly becomes a low impedance as it turns on. This reduces inrush current and related voltage drop that results from charging a capacitive load, satisfying the USB voltage drop requirements, for bus-powered applications as shown in Figure 2.

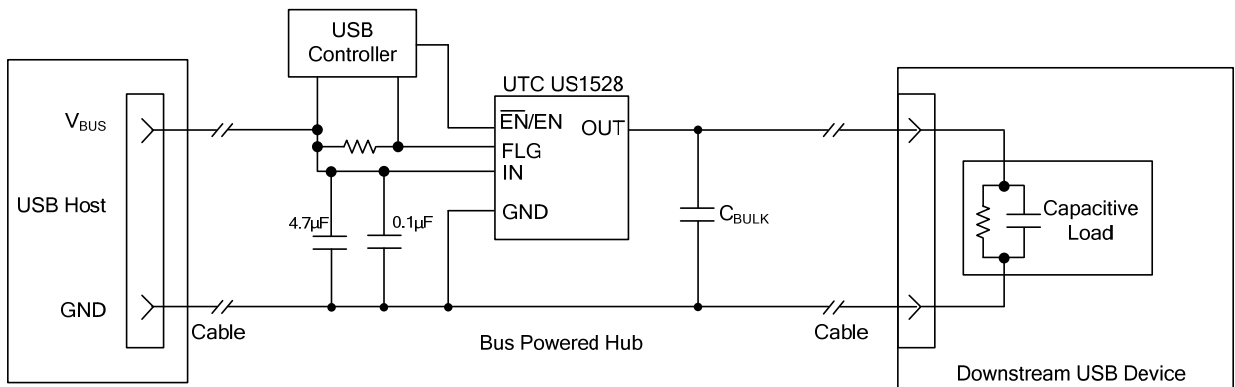

Figure 2. Soft Start

■ APPLICATIONS INFORMATION (Cont.)

In Figure 3, the soft start circuit is shown, and the soft start circuit can be utilized to meet USB transient regulation specifications with large load capacitances ( $C_{BULK} > 10\mu F$ ). The device will provide inrush current limiting for these applications.

When hot-plug events occur, the soft start is used to eliminate the upstream voltage droop due to the inrush current. The soft-start protects power supplies from damage caused by highly capacitive loads.

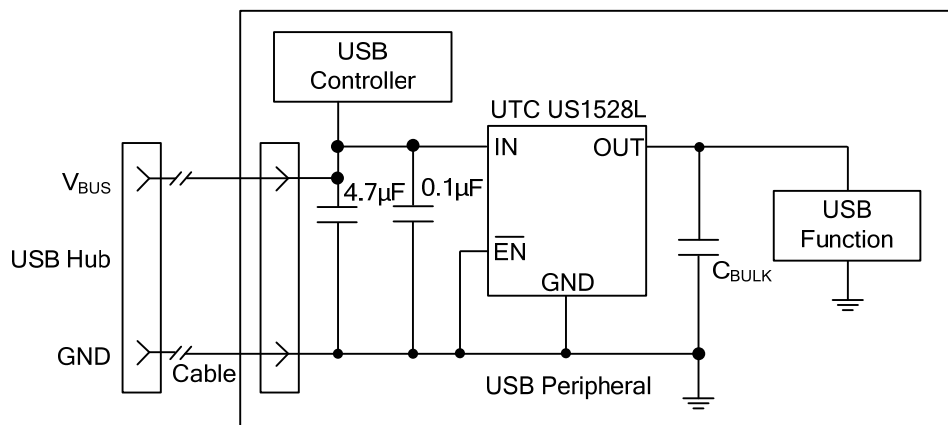
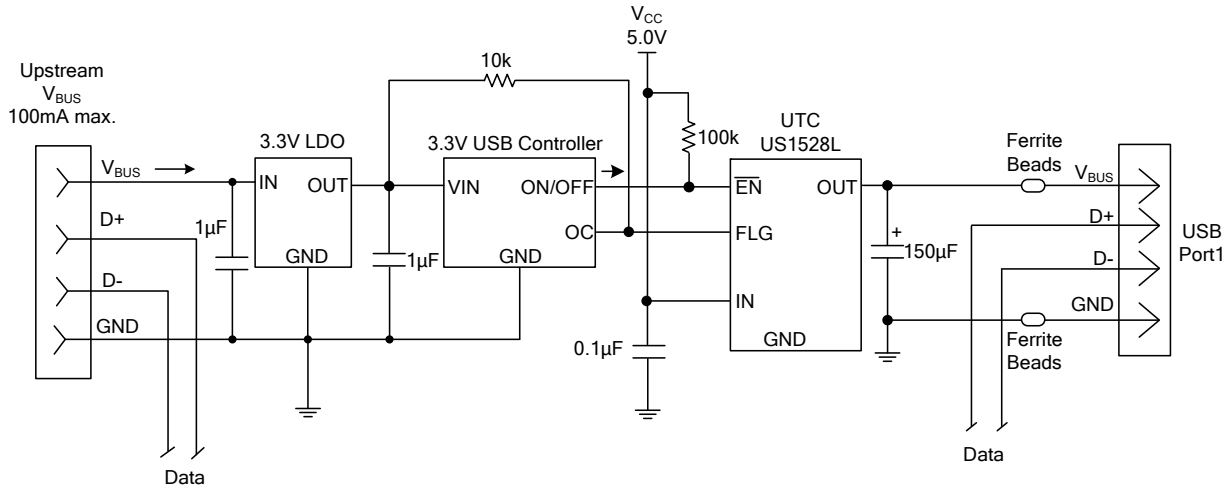

Figure 3. Inrush current-Limit Application

■ TYPICAL APPLICATION CIRCUIT



Single-Port Self-Powered USB Hub Application

UTC assumes no responsibility for equipment failures that result from using products at values that exceed, even momentarily, rated values (such as maximum ratings, operating condition ranges, or other parameters) listed in products specifications of any and all UTC products described or contained herein. UTC products are not designed for use in life support appliances, devices or systems where malfunction of these products can be reasonably expected to result in personal injury. Reproduction in whole or in part is prohibited without the prior written consent of the copyright owner. The information presented in this document does not form part of any quotation or contract, is believed to be accurate and reliable and may be changed without notice.