

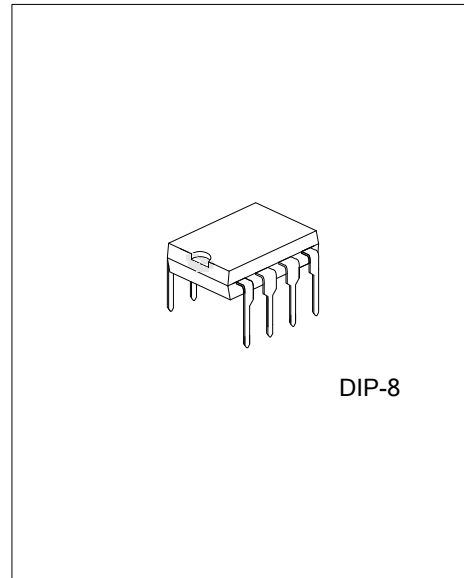

CONSTANT CURRENT CONTROLLER FOR NON-ISOLATED BUCK LED DRIVER



DESCRIPTION

The UTC **USL1602** is a high precision constant current non-isolated buck LED driver controller. It can operate under universal AC input, also can operate 12V~600V DC input. The UTC **USL1602** integrates 600V power MOSFET, so it can use very few external components achieve excellent constant current performance.

The UTC **USL1602** uses high precision current sense circuit, to achieve high precision output current and excellent line regulation. The UTC **USL1602** operates in inductor current critical mode. The LED current is constant over wide range of inductance variation and the LED output voltage, so the load regulation is excellent.

The UTC **USL1602** operation current is 200uA only, so the auxiliary winding is not needed. It can simplify the system design and reduce the system cost.

The UTC **USL1602** offers rich protection functions, including LED short circuit protection, current sense resistor short circuit protection and over temperature protection.

FEATURES

- * Inductor current critical mode, No need to compensate the inductance variation
- * 600V MOSFET integrated
- * Source driver structure, Not need the auxiliary winding for V_{CC}
- * $\pm 3\%$ LED current accuracy
- * Up to 93% system efficiency
- * LED short circuit protection
- * Current sense resistor short circuit protection
- * Over temperature protection

ORDERING INFORMATION

Ordering Number		Package	Packing
Lead Free	Halogen Free		
USL1602L-D08-T	USL1602G-D08-T	DIP-8	Tube

USL1602L-D08-T (1)Packing Type (2)Package Type (3)Green Package	(1) T: Tube (2) D08: DIP-8 (3) L: Lead Free, G: Halogen Free and Lead Free
--	--

MARKING

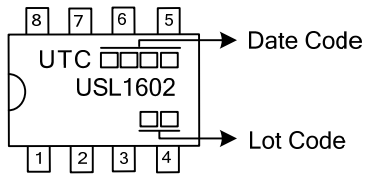

PIN CONFIGURATION

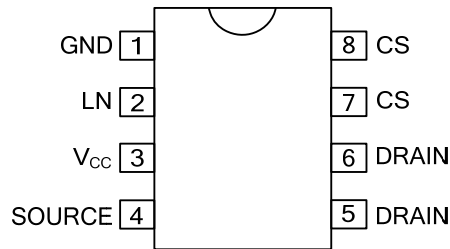

PIN DESCRIPTION

PIN NO.	PIN NAME	DESCRIPTION
1	GND	Ground
2	LN	Line compensation sense input
3	V _{CC}	Power supply, clamp to 12.5V by internal Zener diode
4	SOURCE	Internal HV power MOSFET source
5, 6	DRAIN	Internal HV power MOSFET drain
7, 8	CS	Current sense input, the sense resistor is connected from CS to ground

FLYING 汎翔國際有限公司
 www.flying1688.com

■ BLOCK DIAGRAM

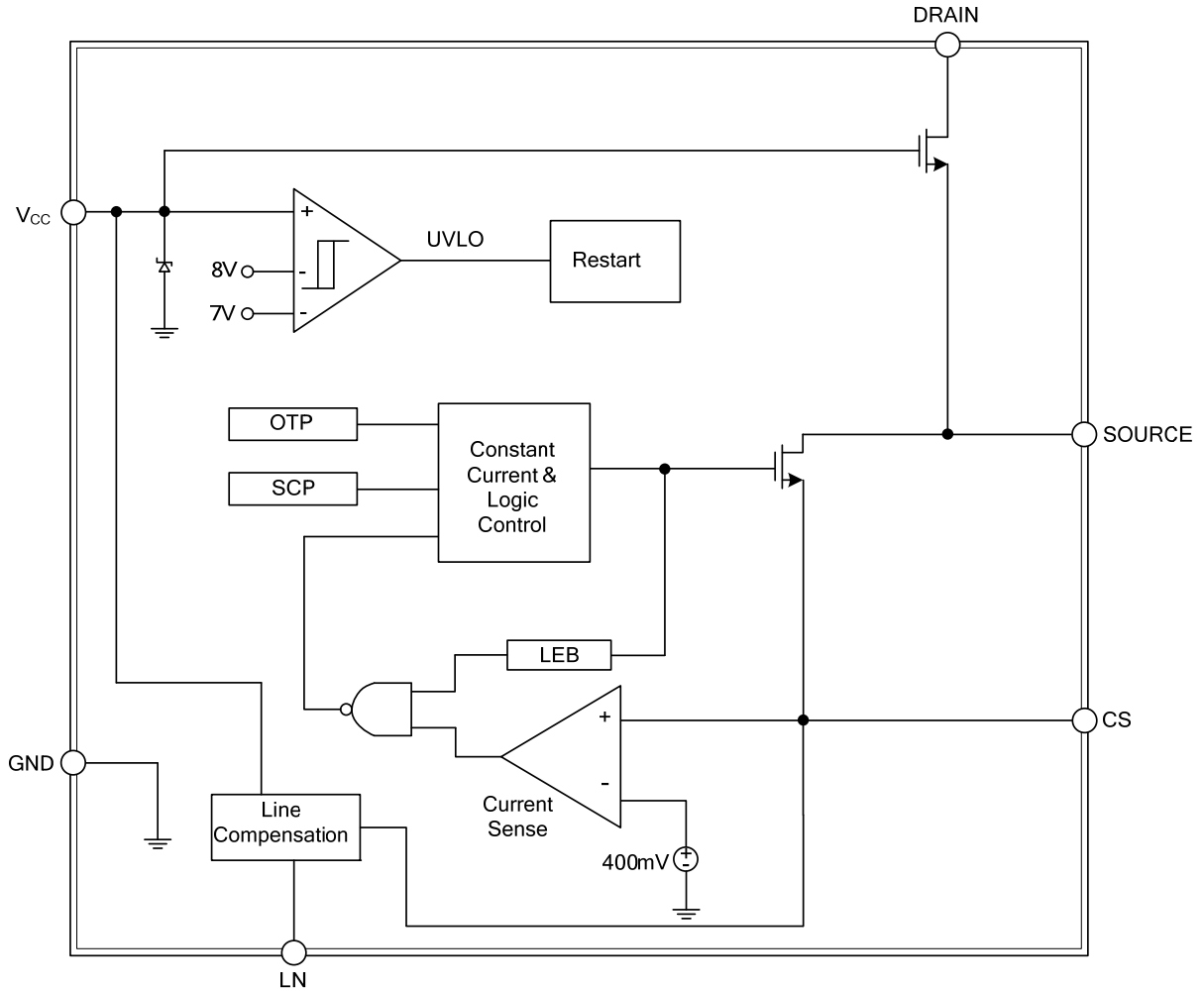

FLYING 汎翔國際有限公司
www.flying1688.com

■ ABSOLUTE MAXIMUM RATING

PARAMETER	SYMBOL	RATINGS	UNIT
Internal HV MOSFET Drain Voltage	V_{DS}	-0.3 ~ 600	V
V_{CC} Pin Maximum Sink Current	$I_{CC,MAX}$	5	mA
Line Compensation Pin Input Voltage	V_{LN}	-0.3 ~ 18	V
Internal HV MOSFET Source Voltage	V_{SOURCE}	-0.3 ~ 18	V
Current Sense Pin Input Voltage	V_{CS}	-0.3 ~ 6	V
Power Dissipation	P_D	0.5	W
Operating Junction Temperature	T_J	-40 ~ +150	°C
Storage Temperature Range	T_{STG}	-55 ~ +150	°C

Note: Absolute maximum ratings are those values beyond which the device could be permanently damaged. Absolute maximum ratings are stress ratings only and functional device operation is not implied.

■ RECOMMENDED OPERATION CONDITIONS

PARAMETER	SYMBOL	RATINGS	UNIT
Output LED Current	I_{LED}	<135	mA

■ THERMAL RESISTANCES CHARACTERISTICS

PARAMETER	SYMBOL	RATING	UNIT
Junction to Ambient	θ_{JA}	150	°C/W

■ ELECTRICAL CHARACTERISTICS (Notes 1, 2) (Unless otherwise specified, $V_{CC}=12V$ and $T_A=25^\circ C$)

PARAMETER	SYMBOL	TEST CONDITIONS	MIN	TYP	MAX	UNIT
Supply Voltage Section						
V_{CC} Clamping Voltage	$V_{CC,CLAMP}$			12.5		V
V_{CC} Clamping Current	$I_{DD,CLAMP}$				5	mA
V_{CC} Start Up Voltage	$V_{CC,ST}$	V_{CC} Rise	7.5	8.3	9.1	V
V_{CC} Under Voltage Latch Out Hysteresis	$V_{UVLO,HYS}$	V_{CC} Falling		1		V
Start Up Current	I_{ST}	$V_{CC}=V_{CC,ST}-0.5V$		70	150	μA
Operation Current	I_{OP}			200		μA
Current Sense Section						
Current Sense Voltage Threshold	$V_{CS,TH}$		390	400	410	mV
Leading Edge Blanking Time	T_{LEB}			350		ns
Turn Off Delay Time	T_{DELAY}			300		ns
Line Compensation Section						
Line Compensation Rate	$\Delta V_{CS}/\Delta(V_{LN}-V_{CC})$			-40		mV/V
Over Temperature Section						
Thermal Shut Down Temperature	T_{SD}			150		°C
Thermal Shut Down Hysteresis	$T_{SD,HYS}$			30		°C
Internal HV MOSFET						
Switch ON Resistance	$R_{DS,ON}$	$V_{CC}=12V$		8		Ω
Drain to Source Voltage	V_{DS}		600			V
Internal Driver Section						
Minimum Demagnetization Time	$T_{OFF,MIN}$			4		μs
Maximum Demagnetization Time	$T_{OFF,MAX}$			130		μs
Maximum Turn On Time	$T_{ON,MAX}$			45		μs

Notes: 1. Production testing of the chip is performed at 25°C.

2. The maximum and minimum parameters specified are guaranteed by test, the typical value are guaranteed by design, characterization and statistical analysis.

■ FUNCTION DESCRIPTION

The UTC **USL1602** is a constant current controller, designed for driving non-isolated buck LED power supply. UTC **USL1602** integrates 600V power MOSFET, excellent constant current characteristic is achieved with low counts components. Low cost and high efficiency of system is realized.

Start up

The V_{CC} will be charged through the startup resistor when the system is powered on. When the voltage on V_{CC} reaches the startup voltage threshold, the controller starts to switching. The V_{CC} voltage of UTC **USL1602** is clamped to 12.5V by internal Zener diode.

Line Compensation

The UTC **USL1602** integrates line compensation function. The line voltage is sensed by the voltage difference between LN and V_{CC} pin. And the internal reference voltage of V_{CS} is compensated by a value proportional to the sensed line voltage. The excellent line regulation is achieved.

The line compensation coefficient is given by the following equation:

$$\Delta V_{CS} = -40 \times 10^{-3} \times (V_{LN} - V_{CC})$$

The V_{CS} is the reference voltage of the internal current sense comparator.

The V_{LN} is the voltage on LN pin.

The V_{CC} is the voltage on V_{CC} pin.

Constant Current Control and Output Current Setting

The UTC **USL1602** uses patent constant current control method, excellent constant current is achieved with low counts components. The UTC **USL1602** senses the peak current in inductor cycle by cycle. The CS Pin is connected to the input of internal current comparator, and compared with the internal 400mV reference voltage. The external power MOSFET will be turned off when the CS pin voltage reaches the voltage threshold. The comparator has a 350ns LEB timer to avoid mis-trigger.

The peak current in the inductor is given by:

$$I_{PK} = \frac{400}{R_{CS}} \text{ (mA)}$$

The R_{CS} is the resistance of current sense resistor

The current in LED can be calculated by the following equation:

$$I_{LED} = \frac{I_{PK}}{2}$$

The I_{PK} is the peak current in inductor

Source Driver Structure

The UTC **USL1602** uses the patent source driver structure. The typical operation current is as low as 200 μ A, the auxiliary winding is not need. So the system design is simple and the cost is low.

■ FUNCTION DESCRIPTION (Cont.)

Inductance Calculation

The UTC **USL1602** is designed to work in inductor current critical mode, the energy will be stored in the inductor when the MOSFET is turned on. The turn on time is given by:

$$t_{on} = \frac{L \times I_{PK}}{V_{IN} - V_{LED}}$$

The L is the inductance.

The I_{PK} is the peak current in inductor.

The V_{IN} is the input rectified voltage.

The V_{LED} is the voltage on LED.

When the power MOSFET is turned off, the inductor current will decrease from the peak current to zero. The turn off time is given by:

$$t_{off} = \frac{L \times I_{PK}}{V_{LED}}$$

The MOSFET will be turned on again when it detects the inductor current goes to zero.

The inductance can be calculated by the following equation:

$$L = \frac{V_{LED} \times (V_{IN} - V_{LED})}{f \times I_{PK} \times V_{IN}}$$

The f is the system switching frequency, which is proportional to the input voltage. So the minimum switching frequency is set at lowest input voltage, and maximum switching frequency is set at highest input voltage.

The UTC **USL1602** internally set the minimum off time to 4 μ s and maximum off time to 130 μ s. When the inductance is very small, the t_{off} may goes below the minimum off time and the inductor current becomes discontinuous. So the output LED current will be smaller than the setting value. If the inductance is too large, the t_{off} may goes beyond the maximum off time and the inductor current becomes continuous. And the output LED current will be larger than the setting value. So it's very important to select a right inductance.

The UTC **USL1602** also internally set the maximum on time to 40 μ s. When the input voltage is very low or LED output voltage is very high, the t_{on} may goes beyond the maximum on time. The power MOSFET will be turned off even the inductor current still below the setting value. So the output LED current will be smaller than the setting value.

Protection Functions

The UTC **USL1602** has many protection functions, including LED short circuit protection, current sense resistor short circuit protection and over temperature protection. All of the protection functions are designed to auto-recover.

The over temperature protection circuitry in the UTC **USL1602** monitors the die junction temperature after start up. When the temperature rises to 150°C, the power MOSFET will be shut down immediately and maintains at switch off condition until the temperature on die falls 30°C below the thermal protection trigger point.

PCB Layout

The following guidelines should be followed in UTC **USL1602** PCB layout:

Bypass Capacitor

The bypass capacitor on V_{CC} pin should be as close as possible to the V_{CC} and GND pins.

Ground Path

The power ground path for current sense should be short, and the power ground path should be separated from small signal ground path before the negative node of the bus capacitor.

The Area of Power Loop

The area of main current loop should be as small as possible to reduce EMI radiation. And the controller should be placed away from the heat generator, such as the power diode.

■ TYPICAL APPLICATION CIRCUIT

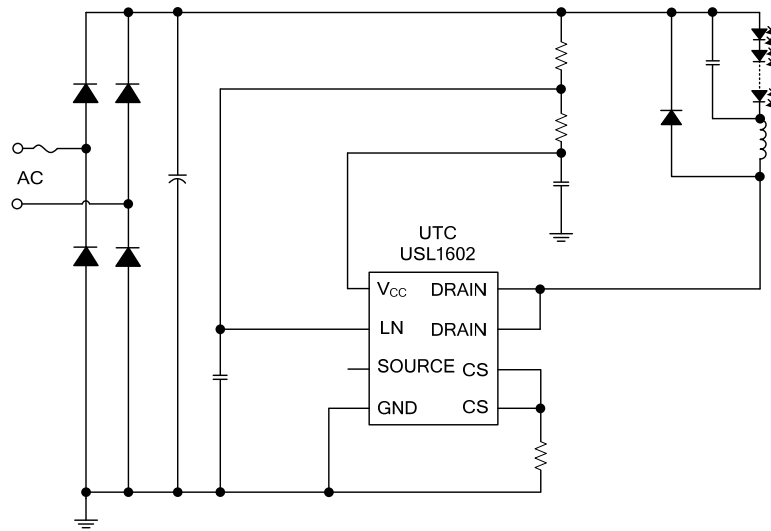

UTC assumes no responsibility for equipment failures that result from using products at values that exceed, even momentarily, rated values (such as maximum ratings, operating condition ranges, or other parameters) listed in products specifications of any and all UTC products described or contained herein. UTC products are not designed for use in life support appliances, devices or systems where malfunction of these products can be reasonably expected to result in personal injury. Reproduction in whole or in part is prohibited without the prior written consent of the copyright owner. The information presented in this document does not form part of any quotation or contract, is believed to be accurate and reliable and may be changed without notice.