



UTM3023

Power MOSFET

N-CHANNEL ENHANCEMENT MODE

FEATURES

- * $R_{DS(ON)} < 20m\Omega @ V_{GS} = 10 V, I_{DS} = 20 A$
 $R_{DS(ON)} < 28m\Omega @ V_{GS} = 5 V, I_{DS} = 10 A$
- * Low capacitance
- * Optimized gate charge
- * Fast switching capability
- * Avalanche energy specified

SYMBOL

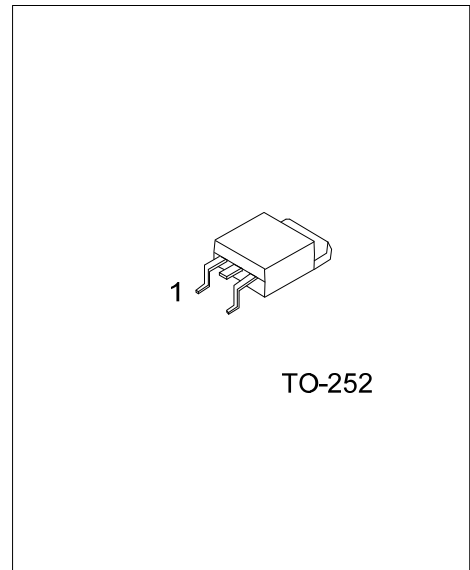
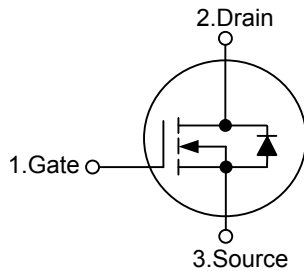

ORDERING INFORMATION

Ordering Number		Package	Pin Assignment			Packing
Lead Free	Halogen Free		1	2	3	
UTM3023L-TN3-T	UTM3023G-TN3-T	TO-252	G	D	S	Tube
UTM3023L-TN3-R	UTM3023G-TN3-R	TO-252	G	D	S	Tape Reel

<p>UTM3023L-TN3-T</p> <p>(1)Packing Type</p> <p>(2)Package Type</p> <p>(3)Lead Plating</p>	<p>(1) T: Tube, R: Tape Reel</p> <p>(2) TN3: TO-252</p> <p>(3) L: Lead Free, G: Halogen Free</p>
--	--



■ ABSOLUTE MAXIMUM RATINGS ($T_A = 25^\circ\text{C}$, unless otherwise specified)

PARAMETER	SYMBOL	RATINGS	UNIT
Drain-Source Voltage	V_{DSS}	30	V
Gate-Source Voltage	V_{GSS}	± 20	
Maximum Continuous Drain Current	I_D	30	A
Maximum Pulsed Drain Current	I_{DM}	70	
Maximum Power Dissipation	P_D	62.5	W
Maximum Junction Temperature	T_J	150	$^\circ\text{C}$
Storage Temperature Range	T_{STG}	-55 ~ +150	

Note: Absolute maximum ratings are those values beyond which the device could be permanently damaged. Absolute maximum ratings are stress ratings only and functional device operation is not implied.

■ ELECTRICAL CHARACTERISTICS ($T_J = 25^\circ\text{C}$, unless otherwise noted)

PARAMETER	SYMBOL	TEST CONDITIONS	MIN	TYP	MAX	UNIT
OFF CHARACTERISTICS						
Drain-Source Breakdown Voltage	BV_{DSS}	$V_{GS} = 0\text{ V}, I_{DS} = 250\mu\text{A}$	30			V
Drain-Source Leakage Current	I_{DSS}	$V_{DS} = 24\text{ V}, V_{GS} = 0\text{ V}$			1	μA
Gate-Source Leakage Current	I_{GSS}	$V_{DS} = 0\text{ V}, V_{GS} = \pm 20\text{V}$			± 100	nA
ON CHARACTERISTICS						
Gate Threshold Voltage	$V_{GS(TH)}$	$V_{DS} = V_{GS}, I_{DS} = 250\mu\text{A}$	1	1.5	2	V
Drain-Source On-State Resistance(Note 2)	$R_{DS(ON)}$	$V_{GS} = 10\text{ V}, I_{DS} = 20\text{ A}$		15	20	m Ω
		$V_{GS} = 5\text{ V}, I_{DS} = 10\text{ A}$		22	28	
DYNAMIC CHARACTERISTICS						
Input Capacitance	C_{ISS}	$V_{DS} = 15\text{ V}, V_{GS} = 0\text{V}, f = 1.0\text{MHz}$		1200		pF
Output Capacitance	C_{OSS}			220		
Reverse Transfer Capacitance	C_{RSS}			100		
SWITCHING CHARACTERISTICS						
Turn-ON Delay Time (Note 2)	$t_{D(ON)}$	$I_{DS} = 2\text{ A}, V_{DD} = 15\text{ V}, R_G = 6\Omega, V_{GEN} = 10\text{V}$		11	18	ns
Turn-ON Rise Time	t_R			17	26	
Turn-OFF Delay Time	$t_{D(OFF)}$			37	54	
Turn-OFF Fall Time	t_F			20	30	
Total Gate Charge (Note 2)	Q_G	$V_{DS} = 15\text{V}, V_{GS} = 5\text{V}, I_{DS} = 10\text{A}$		15	20	nC
Gate-Source Charge	Q_{GS}			5.8		
Gate-Drain Charge	Q_{GD}			3.8		
SOURCE- DRAIN DIODE RATINGS AND CHARACTERISTICS						
Drain-Source Diode Forward Voltage(Note2)	V_{SD}	$I_{SD} = 15\text{A}, V_{GS} = 0\text{V}$		0.7	1.3	V

Note: 1. Pulse width limited by $T_{J(MAX)}$
 2. Pulse width $\leq 300\mu\text{s}$, duty cycle $\leq 2\%$
 3. Surface Mounted on FR4 Board, $t \leq 10\text{ sec}$.

■ TYPICAL CHARACTERISTICS

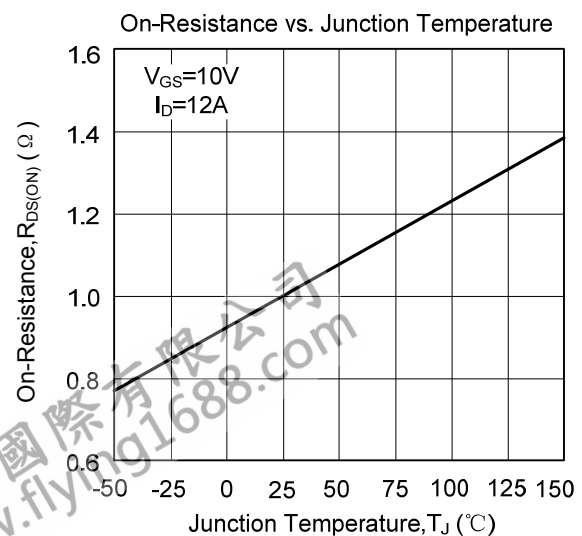
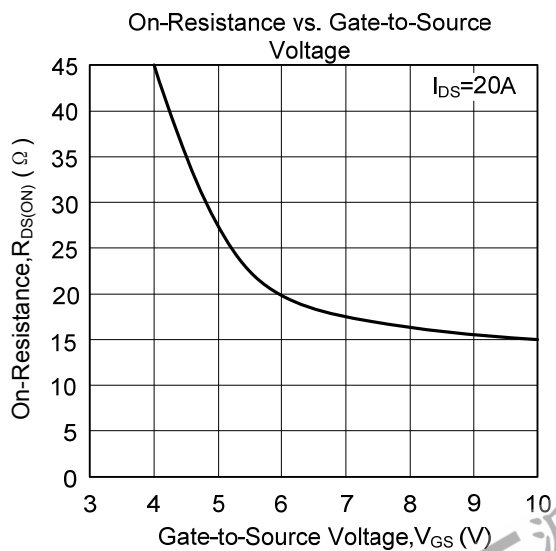
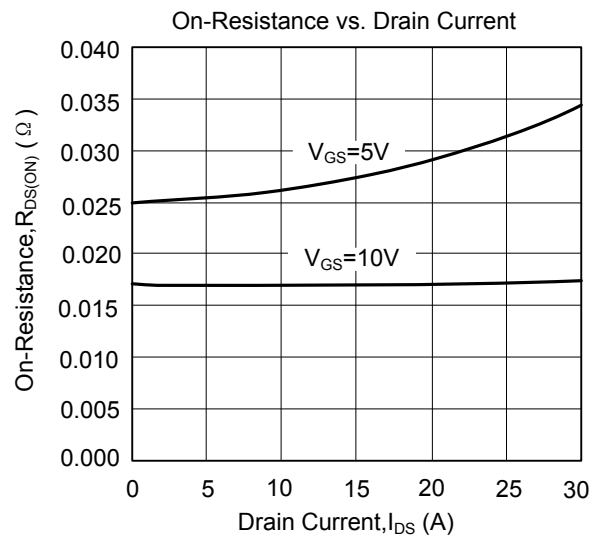
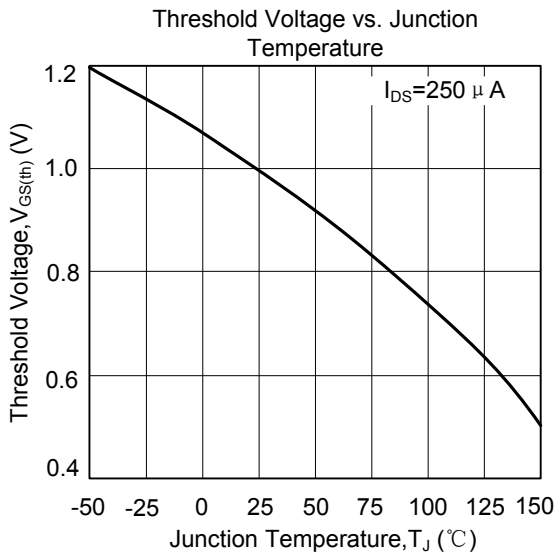
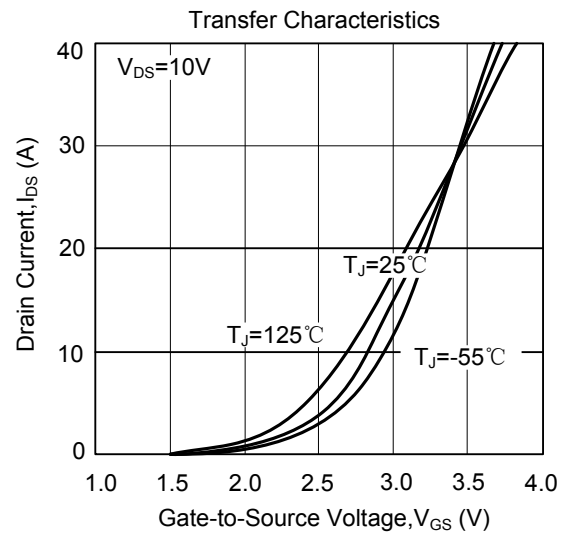
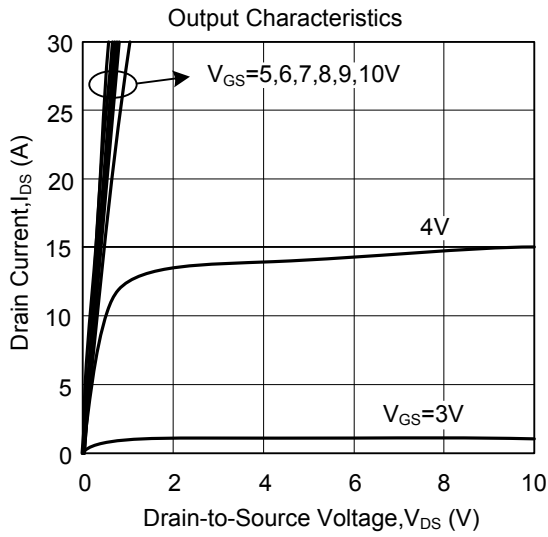

TYPICAL CHARACTERISTICS(Cont.)

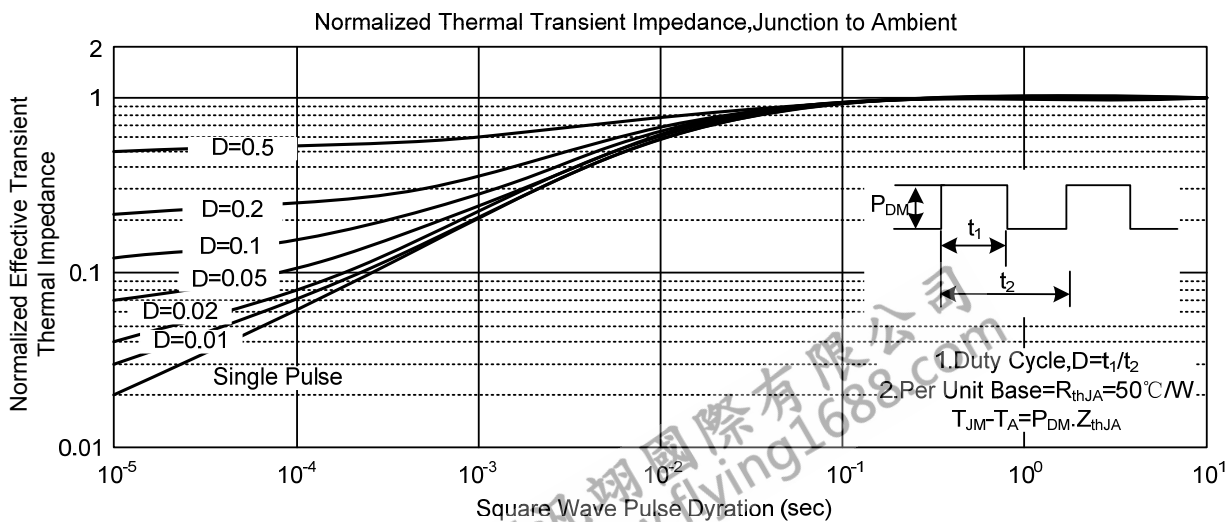
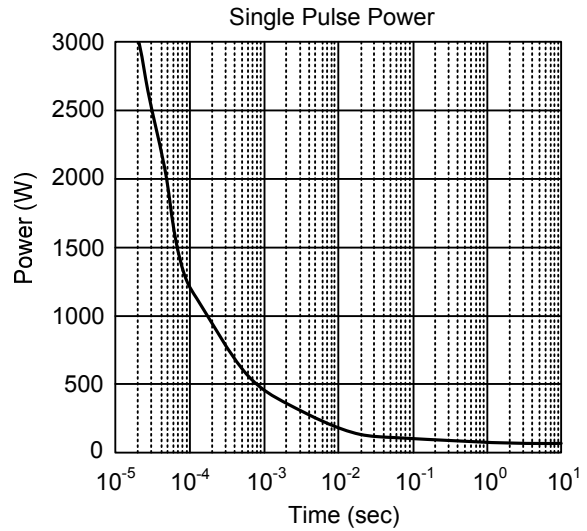
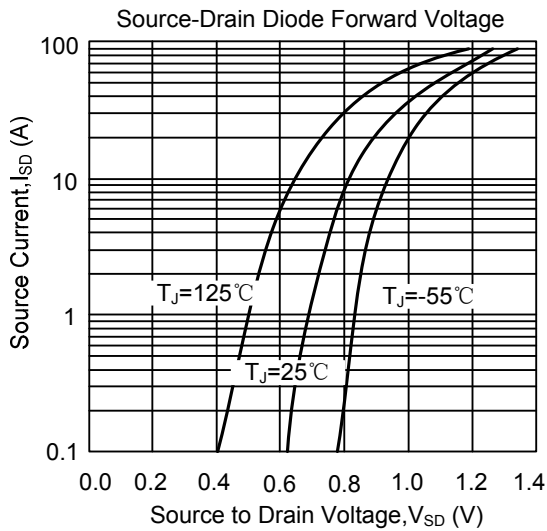
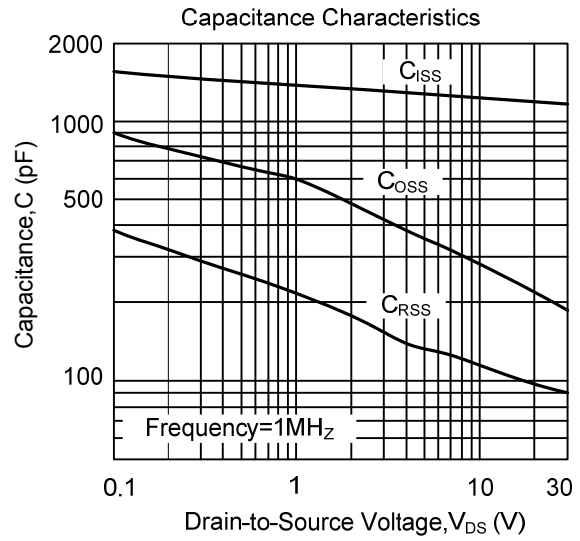
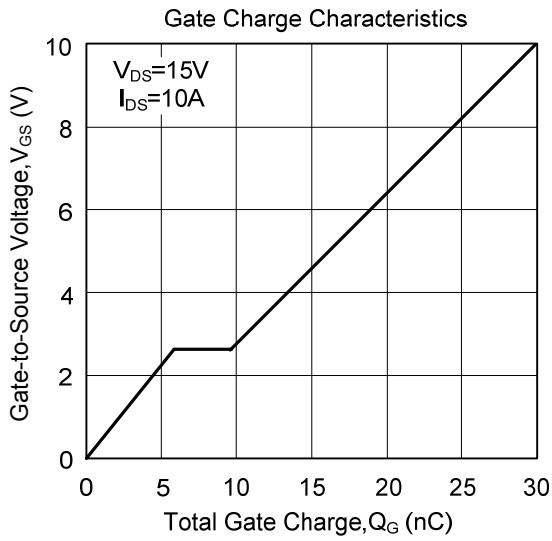

UTC assumes no responsibility for equipment failures that result from using products at values that exceed, even momentarily, rated values (such as maximum ratings, operating condition ranges, or other parameters) listed in products specifications of any and all UTC products described or contained herein. UTC products are not designed for use in life support appliances, devices or systems where malfunction of these products can be reasonably expected to result in personal injury. Reproduction in whole or in part is prohibited without the prior written consent of the copyright owner. The information presented in this document does not form part of any quotation or contract, is believed to be accurate and reliable and may be changed without notice.