

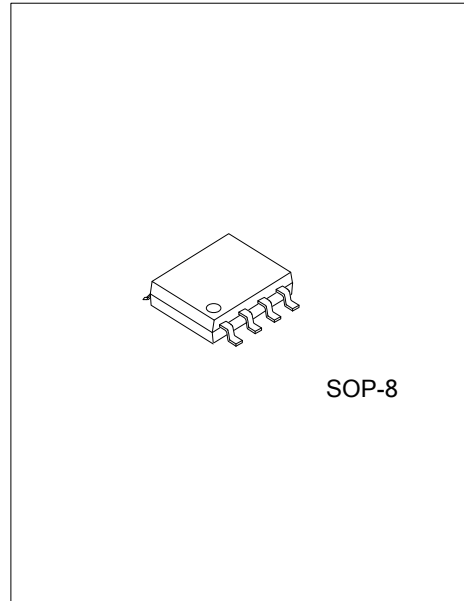

LOW-COST Three-Channel 4TH-ORDER STANDARD- DEFINITION VIDEO FILTERS



DESCRIPTION

The UTC **VF8143** Low-Cost Video Filter (LCVF) offers three channels of 4th-order filters for standard-definition and drivers with a low-cost integrated device.

The UTC **VF8143** inputs feature a transparent clamp compatible with AC- coupled and DC-coupled input signals and allows DAC outputs to be directly coupled.

The outputs can drive AC- or DC-coupled single (150Ω) or dual (75Ω) loads. The input DC levels are offset approximately +280mV at the output (see Applications section for details).

The UTC **VF8143** is ideal for DAC smoothing in applications such as cable set-top boxes, satellite set-top boxes, HDTV, video on demand (VOD), DVD players, and personal video recorders.

FEATURES

- * Three-Channel 4th-order 8MHz filters for SD video
- * Transparent input clamping
- * AC-or DC-coupled inputs
- * AC-or DC-coupled outputs
- * Drives single, +6dB output (150Ω)
- * Drives dual, +6dB output (75Ω)
- * DC-coupled outputs eliminate AC-coupling capacitors
- * Single +5V power supply
- * Robust 8kV ESD protection

ORDERING INFORMATION

Ordering Number		Package	Packing
Lead Free	Halogen Free		
VF8143L-S08-R	VF8143G-S08-R	SOP-8	Tape Reel

<p>VF8143G-S08-R</p> <ul style="list-style-type: none"> (1) Packing Type (2) Package Type (3) Green Package 	<ul style="list-style-type: none"> (1) R: Tape Reel (2) S08: SOP-8 (3) G: Halogen Free and Lead Free, L: Lead Free
--	---

MARKING

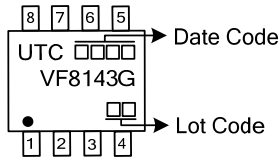

PIN CONFIGURATION

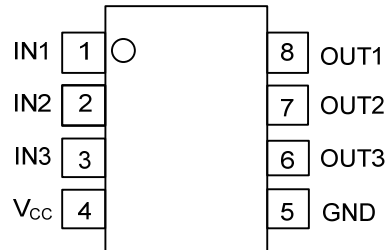

PIN DESCRIPTION

PIN NO.	PIN NAME	DESCRIPTION
1	IN1	Video input, Channel 1
2	IN2	Video input, Channel 2
3	IN3	Video input, Channel 3
4	V _{CC}	+5V supply, do not float
5	GND	Must be tied to ground, do not float
6	OUT3	Filtered output, Channel 3
7	OUT2	Filtered output, Channel 2
8	OUT1	Filtered output, Channel 1

BLOCK DIAGRAM

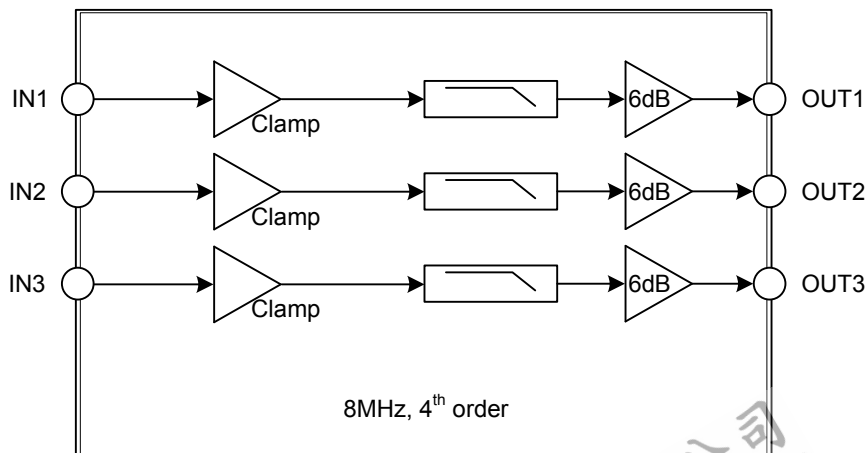

■ ABSOLUTE MAXIMUM RATING

PARAMETER	SYMBOL	RATINGS	UNIT
DC Supply Voltage	V_{CC}	-0.3~6	V
Analog and Digital I/O		-0.3~ $V_{CC}+0.3$	V
Output Channel-Any One Channel (Do Not Exceed)		50	mA
Junction Temperature	T_J	+150	°C
Operating Temperature	T_{OPR}	-40~+85	°C
Storage Temperature	T_{STG}	-65~+150	°C

Note: Absolute maximum ratings are those values beyond which the device could be permanently damaged.
Absolute maximum ratings are stress ratings only and functional device operation is not implied.

■ THERMAL DATA

PARAMETER	SYMBOL	RATINGS	UNIT
Thermal Resistance, JEDEC Standard Multi-layer Test Boards, Still Air	θ_{JA}	115	°C/W

■ RECOMMENDED OPERATING CONDITIONS

PARAMETER	SYMBOL	TEST CONDITIONS	MIN	TYP	MAX	UNIT
V_{CC} Range			4.75	5.0	5.25	V

■ DC ELECTRICAL CHARACTERISTICS

($T_A=25^\circ\text{C}$, $V_{CC}=5\text{V}$, $R_{SOURCE}=37.5\Omega$, all inputs are AC coupled with $0.1\mu\text{F}$, all outputs are AC coupled with $220\mu\text{F}$ into 150Ω loads, unless otherwise noted.)

PARAMETER	SYMBOL	TEST CONDITIONS	MIN	TYP	MAX	UNIT
Supply Current (Note 1)	I_{CC}	No Load		19	27	mA
Video Input Voltage	V_{IN}	Referenced to GND if DC coupled		1.4		V_{PP}
Power Supply Rejection	PSRR	DC (All Channels)		-50		dB

Note: 1. 100% tested at 25°C .

■ AC ELECTRICAL CHARACTERISTICS

($T_A=25^\circ\text{C}$, $V_{IN}=1V_{PP}$, $V_{CC}=5\text{V}$, $R_{SOURCE}=37.5\Omega$, all inputs are AC coupled with $0.1\mu\text{F}$, all outputs are AC coupled with $220\mu\text{F}$ into 150Ω loads, unless otherwise noted.)

PARAMETER	SYMBOL	TEST CONDITIONS	MIN	TYP	MAX	UNIT
Channel Gain (Note 1)	AV	All Channels	6.0	6.2	6.4	dB
-1dB Bandwidth (Note 1)	f_{1dB}	All Channels	5.6	6.5		MHz
-3dB Bandwidth	f_c	All Channels		7.7		MHz
Attenuation (Stopband Reject)	f_{SB}	All Channels at $f=27\text{MHz}$		48		dB
Differential Gain	dG	All Channels		0.3		%
Differential Phase	d Φ	All Channels		0.6		°
Output Distortion (All Channels)	THD	$V_{OUT}=1.8V_{PP}$, 1MHz		0.4		%
Crosstalk (Channel-to-Channel)	X_{TALK}	at 1MHz		-60		dB
Signal-to-Noise Ratio	SNR	All Channels NTC-7 Weighting: 100kHz~4.2MHz		75		dB
Propagation Delay	t_{pd}	Delay from Input-to-Output, 4.5MHz		59		ns

Note: 1. 100% tested at 25°C .

■ TYPICAL APPLICATION CIRCUIT

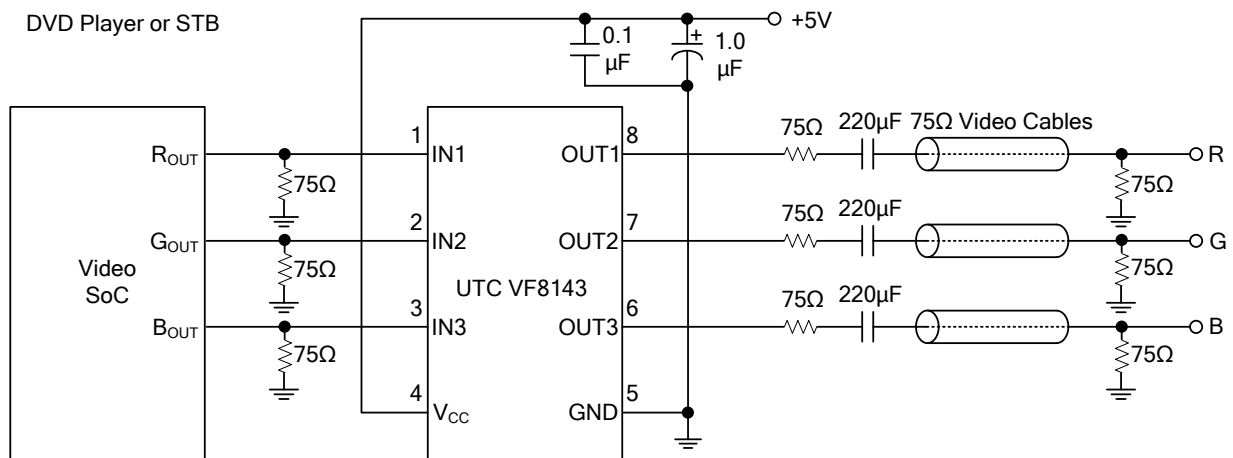

UTC assumes no responsibility for equipment failures that result from using products at values that exceed, even momentarily, rated values (such as maximum ratings, operating condition ranges, or other parameters) listed in products specifications of any and all UTC products described or contained herein. UTC products are not designed for use in life support appliances, devices or systems where malfunction of these products can be reasonably expected to result in personal injury. Reproduction in whole or in part is prohibited without the prior written consent of the copyright owner. The information presented in this document does not form part of any quotation or contract, is believed to be accurate and reliable and may be changed without notice.